

:

()

- 1.
- 2.
- 3.

:

.





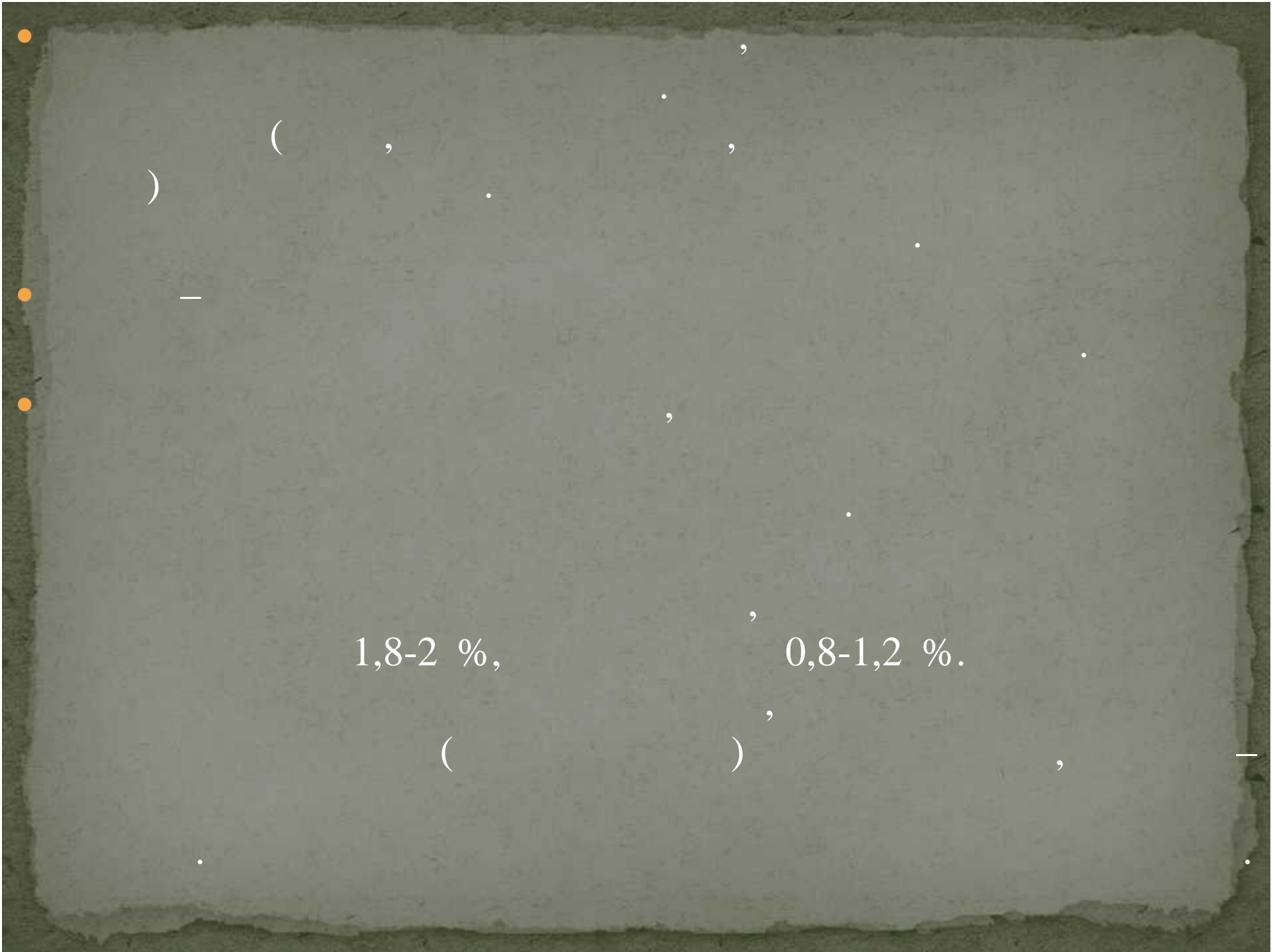

1,8-2 %,

0,8-1,2 %.

()



(28-).

(1)

(2)

;

(3)

,

(4)

.

;

(5)

() (6)

.

.



()

(6.1- ,) -

(6.1- ,).

,

(6.1- ,)

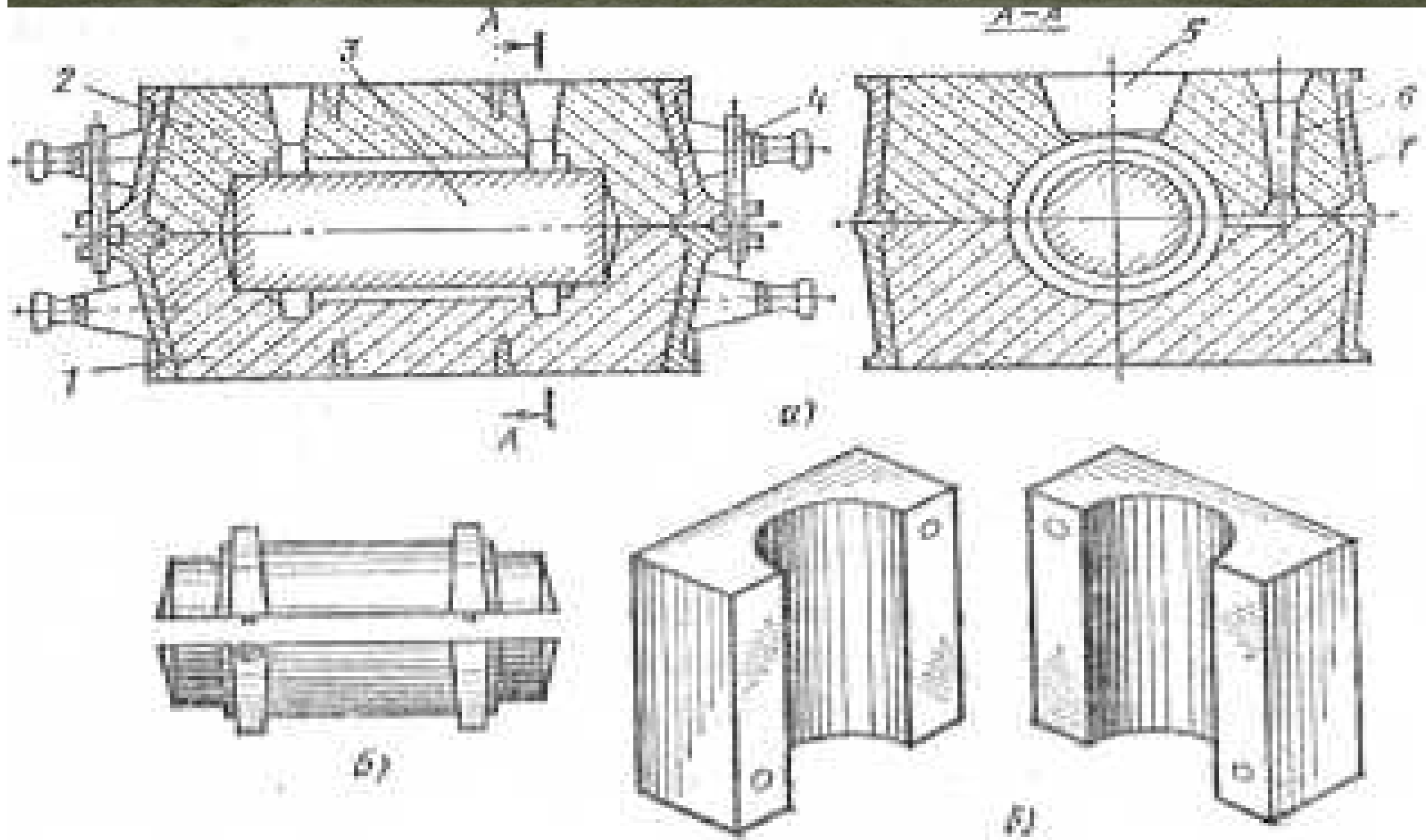

(
—

)

(6.2-).

.

,

.

.

.

;

.

.

.

.

