

## LCD monitorni boshqarish

### LCD monitoring ulanish sxemasi tavsifi

Arduino UNO platasida LCD monitorini ulanish sxemasida o'zgaruvchan rezistor, manbalar va LCD 1602 displeydan iborat.

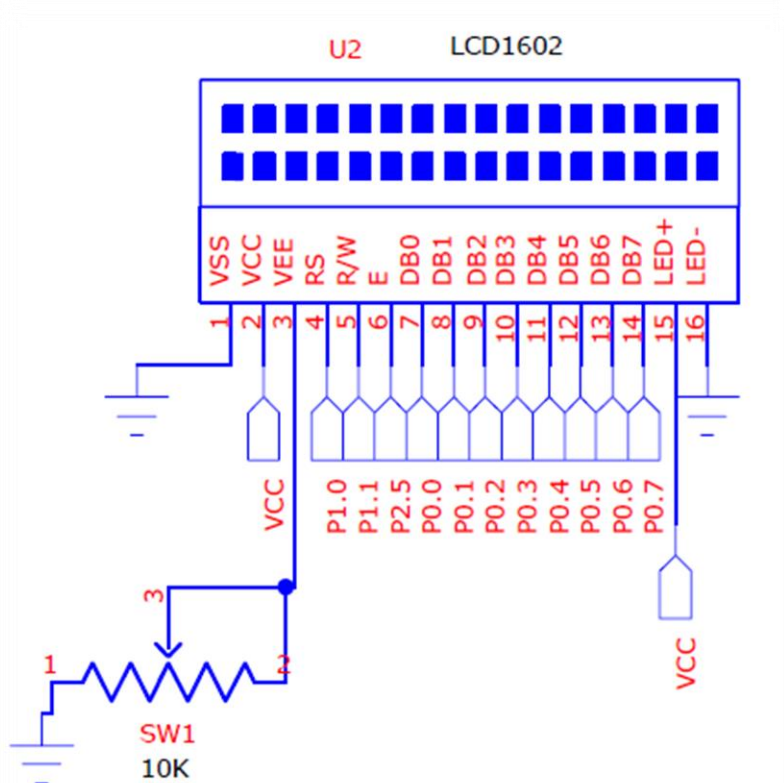

- Sxemada o'zgaruvchan rezistordan foydalangan bo'lib, uning qarshiligi 10K Om, ya'ni bu o'zgaruvchan rezistorning qiymatini 0-10K Om qiymatda o'zgartirish mumkin. O'zgaruvchan rezistorlar ham sxemada oddiy rezistorlar kabi tokni cheklash uchun foydalaniladi, ularning farqi esa o'zgaruvchan rezistorlarni nominal qarshiligini o'zgartirish mumkin. O'z navbatida o'zgaruvchan rezistorlar nominal quvvati va nominal qarshiligi bo'yicha farqlanadi.

O'zgaruvchan rezistorning belgilanishi:

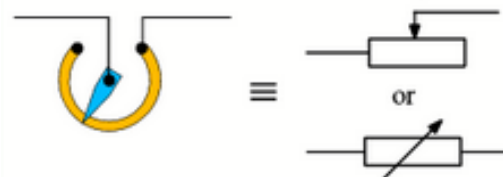

O'zgaruvchan rezistor turlari:

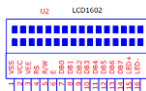

- Sxemada LCD 1602 displeydan foydalanilgan bo'lib uning tashqi ko'rinishi quyidagicha:

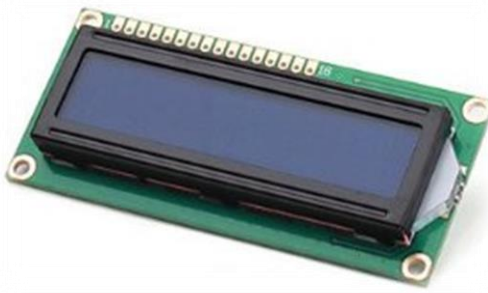

Display xarakteristikalari quyidagicha:

- Texnologiya STN, Transflective, Positive 16\*2 simvolli format;
- Kontroller SPLC780D1;
- Interfeys 8-bit Parallel Interface;
- Yashil fonli qora yozuvdan foydalanilgan;
- Svetodioldi yoritish tizimi;
- Ko'rinish burchagi 180°;
- Manba kuchlanishi 5 V;
- Ishchi temperatura -20 ~ 70 C°;

Displeyning 16ta chiqishi ya'ni oyoqchasi bo'lib, ularning nomlari quyidagicha:

- 1 - GND (yerlash);
- 2 - VIN (+5B manba);
- 3 - VO yoritilganlikni o'rnatish;
- 4 - RS (ma'lumotlar komandasi);
- 5 - RW (yozuv);
- 6 - E (Enable);
- 7-14 - (DB0...7) ma'lumotlar liniyasi;
- 15 - LED+ (yoritishga + ulash);
- 16 - LED- (yoritishga - ulash).

**LCD monitorni boshqarish loyihasi**

Sxema asosida P1.0,...,P0.7 portlarga ulangan U2 belgilanishi LCD1602, yani 2 qator, 16 belgili monitorida ixtiyoriy matnni shakllantirish ko'rib chiqiladi.

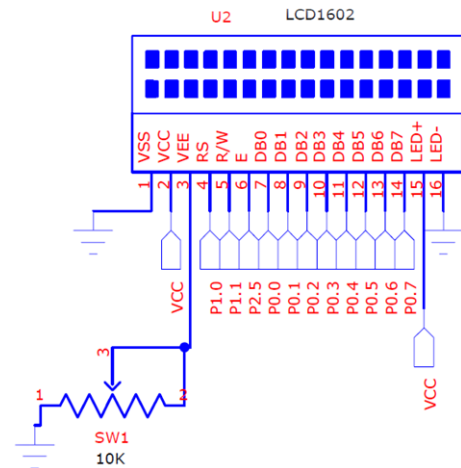

Keil uVision paketida yangi **13\_lab** nomli loyiha va **13\_lab.c** dasturiy fayl yaratiladi. Sxema asosida dasturi yoziladi.

Dasturning birinchi qismi:

**#include<reg52.h>** – ushbu preprocessor derektivasi dasturdagi fayllarga bog'lanishni anglatadi. **reg52** Atmel firmasining 89C52 mikroprosessoridir.

**#include<intrins.h>** - **\_nop\_()** funksiyasini ishlatish uchun xizmat qiluvchi derektiva;

**sbit RS = P1^0;**

**sbit RW = P1^1;**

**sbit EN = P2^5;**

**sbit DU = P2^0;**

**sbit WE = P2^1;** - sxema asosida LCD monitoring mikrokontroller oyoqlariga ulashish qiymatlarini o'zgaruvchilarga bog'lash;

**#define RS\_CLR RS=0**

**#define RS\_SET RS=1**

**#define RW\_CLR RW=0**

**#define RW\_SET RW=1**

**#define EN\_CLR EN=0**

**#define EN\_SET EN=1**

**#define DataPort P0** – ifodalarga o'rindosh ifodalarni belgilash;

```

13_lab.c
001 #include<reg52.h>
002 #include<intrins.h>
003
004 sbit RS = P1^0;
005 sbit RW = P1^1;
006 sbit EN = P2^5;
007 sbit DU = P2^0;
008 sbit WE = P2^1;
009
010 #define RS_CLR RS=0
011 #define RS_SET RS=1
012
013 #define RW_CLR RW=0
014 #define RW_SET RW=1
015
016 #define EN_CLR EN=0
017 #define EN_SET EN=1
018
019 #define DataPort P0
020

```

Dasturning ikkinchi qismi:

```
void cmg88()
```

```
{
```

```
DU=1;
```

```
PO=0X00;
```

```
DU=0;
```

}– cmg88() funksiyasini e’lon qilish va uning tarkibiy tanasini shakllantirish, asosiy maqsadi LCD monitorni aktivlashtirish;

```
void DelayUs2x(unsigned char t)
```

```
{
```

```
while(--t);
```

```
}
```

```
void DelayMs(unsigned char t)
```

```
{
```

```
while(t--)
```

```
{
```

```
DelayUs2x(245);
```

```
DelayUs2x(245);
```

```
}
```

}– uzilish funksiyalari;

Dasturning uchinchi qismi:

```
bit LCD_Check_Busy(void)
```

```
{
```

```
DataPort= 0xFF;
```

```
RS_CLR;
```

```
RW_SET;
```

```
EN_CLR;
```

```
_nop_();
```

```
EN_SET;
```

```
return (bit)(DataPort & 0x80);
```

} – qiymat qaytaruvchi funksiya bo’lib, asosiy maqsadi LCD monitoring ekranidagi mavjud simvollarni aniqlash;

```
void LCD_Write_Com(unsigned char com)
```

```
{
```

```
while(LCD_Check_Busy());
```

```
RS_CLR;
```

```
RW_CLR;
```

```
EN_SET;
```

```
DataPort= com;
```

```
_nop_();
```

```
EN_CLR;
```

} – funksiya bo’lib, ekranga buyrur berishni tashkillashtirsh;

```
020 |
021 | void cmg88 ()
022 | {
023 |     DU=1;
024 |     PO=0X00;
025 |     DU=0;
026 | }
027 | void DelayUs2x(unsigned char t)
028 | {
029 |     while(--t);
030 | }
031 | void DelayMs(unsigned char t)
032 | {
033 |
034 |     while(t--)
035 |     {
036 |         DelayUs2x(245);
037 |         DelayUs2x(245);
038 |     }
039 | }
040 |
```

```
040 |
041 | bit LCD_Check_Busy(void)
042 | {
043 |     DataPort= 0xFF;
044 |     RS_CLR;
045 |     RW_SET;
046 |     EN_CLR;
047 |     _nop_();
048 |     EN_SET;
049 |     return (bit)(DataPort & 0x80);
050 | }
051 | void LCD_Write_Com(unsigned char com)
052 | {
053 |     while(LCD_Check_Busy());
054 |     RS_CLR;
055 |     RW_CLR;
056 |     EN_SET;
057 |     DataPort= com;
058 |     _nop_();
059 |     EN_CLR;
060 | }
```

Dasturning to'rtinchi qismi:

```
void LCD_Write_Data(unsigned char Data)
```

```
{  
  while(LCD_Check_Busy());  
  RS_SET;  
  RW_CLR;  
  EN_SET;  
  DataPort= Data;  
  _nop();  
  EN_CLR;  
} – LCD monitoriga ma'lumot kiritishni shakllantirish  
funksiyasi;
```

```
void LCD_Clear(void)
```

```
{  
  LCD_Write_Com(0x01);  
  DelayMs(5);  
} – LCD ekranini tozalash funksiyasi;
```

Dasturning beshinchi qismi:

```
void LCD_Write_String
```

```
(unsigned char x, unsigned char y,  
unsigned char *s)
```

```
{  
  if (y == 0)  
  {  
    LCD_Write_Com(0x80 + x);  
  }  
  else  
  {  
    LCD_Write_Com(0xC0 + x);  
  }  
  while (*s)  
  {  
    LCD_Write_Data(*s);  
    s ++;  
  }  
} – LCD monitor ekraniga qator toifasidagi  
ma'lumotni kiritish funksiyasi;
```

```
064 void LCD_Write_Data(unsigned char Data)  
065 {  
066   while(LCD_Check_Busy());  
067   RS_SET;  
068   RW_CLR;  
069   EN_SET;  
070   DataPort= Data;  
071   _nop();  
072   EN_CLR;  
073 }  
074  
075 void LCD_Clear(void)  
076 {  
077   LCD_Write_Com(0x01);  
078   DelayMs(5);  
079 }
```

```
078 void LCD_Write_String  
079 (unsigned char x, unsigned char y,  
080 unsigned char *s)  
081 {  
082   if (y == 0)  
083   {  
084     LCD_Write_Com(0x80 + x);  
085   }  
086   else  
087   {  
088     LCD_Write_Com(0xC0 + x);  
089   }  
090   while (*s)  
091   {  
092     LCD_Write_Data(*s);  
093     s ++;  
094   }  
095 }
```

Dasturning oltinchi qismi:

```
void LCD_Write_Char
(unsigned char x,
unsigned char y,
unsigned char Data)
{
if (y == 0)
{
LCD_Write_Com(0x80 + x);
}
else
{
LCD_Write_Com(0xC0 + x);
}
LCD_Write_Data( Data);
}
```

} – LCD monitor ekraniga belgi toifasidagi ma'lumotni kiritish funksiyasi;

Dasturning yettinchi qismi:

```
void LCD_Init(void)
{
LCD_Write_Com(0x38);
DelayMs(5);
LCD_Write_Com(0x38);
DelayMs(5);
LCD_Write_Com(0x38);
DelayMs(5);
LCD_Write_Com(0x38);
LCD_Write_Com(0x08);
LCD_Write_Com(0x01);
LCD_Write_Com(0x06);
DelayMs(5);
LCD_Write_Com(0x0C);
}
```

} – LCD monitorni initizasiyalash funksiyasi;

Dasturning sakkizinchi qismi:

```
void main(void)
{
cmg88();
LCD_Init();
LCD_Clear();
while (1)
{
LCD_Write_Char(7,0,'O');
LCD_Write_Char(8,0,'K');
LCD_Write_String(1,1,"Salom!!!");
while(1);
}
}
```

} – dasturning asosiy tanasi bo'lib, LCD monitorga "O", "K" belgi va "SALOM!!!" matnlarining ekranga chiqarish jarayoni shakllangan;

```
098 void LCD_Write_Char
099 (unsigned char x,
100 unsigned char y,
101 unsigned char Data)
102 {
103 if (y == 0)
104 {
105 LCD_Write_Com(0x80 + x);
106 }
107 else
108 {
109 LCD_Write_Com(0xC0 + x);
110 }
111 LCD_Write_Data( Data);
112 }
```

```
114
115 void LCD_Init(void)
116 {
117 LCD_Write_Com(0x38);
118 DelayMs(5);
119 LCD_Write_Com(0x38);
120 DelayMs(5);
121 LCD_Write_Com(0x38);
122 DelayMs(5);
123 LCD_Write_Com(0x38);
124 LCD_Write_Com(0x08);
125 LCD_Write_Com(0x01);
126 LCD_Write_Com(0x06);
127 DelayMs(5);
128 LCD_Write_Com(0x0C);
129 }
```

```
131
132 void main(void)
133 {
134 cmg88();
135 LCD_Init();
136 LCD_Clear();
137 while (1)
138 {
139 LCD_Write_Char(7,0,'O');
140 LCD_Write_Char(8,0,'K');
141 LCD_Write_String(1,1,"Salom!!!");
142 while(1);
143 }
144 }
```

Natija: OK belgilari birinchi qator, 7 va 8 yacheykada, SALOM!!! so'zi esa, ikkinchi qator yacheykalarida akslanadi.

