

12-MA`RUZA MEXANIZMLAR VA MASHINALAR NAZARIYASI. MEXANIZMLARNING ASOSIY TURLARI. KINEMATIK JUFTLAR KLASSIFIKATSIYASI. MEXANIZMNING ERKINLIK DARAJASINI ANIQLASH.

Reja:

1. Mexanizmlarning asosiy turlari
2. Kinematik juftlar klassifikatsiyasi
3. Mexanizmning erkinlik darajasini aniqlash

Mashinasozlikda ishlatiladigan mexanizmlarni konstruksiyasiga qarab quyidagi guruxlarga bo'lish mumkin.

1. Richagli mexanizmlar.
2. Kulachokli mexanizmlar.
3. Shesternyali (tishli g'ildirakli) mexanizmlar
4. Vintli va pog'onali mexanizmlar.
5. Friksion mexanizmlar.
6. Egiluvchan zvenoli mexanizmlar.
7. Gidravlik va pnevmantik mexanizmlar.
8. Elektrik mexanizmlar.

Richagli mexanizmlar.

- 1-qo'zg'almas zveno.
- 2-qo'zg'aluvchan zveno.

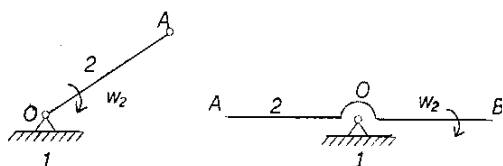

Ikki zvenoli mexanizmlar.

- 1-qo'zg'almas zveno.
- 2-tirsakli val (krivoship)
- 3-shatun.
- 4-koromislo.

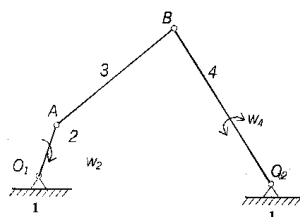

To'rt zvenoli mexanizmlar.

Sharnirli to'rt zvenoli mexanizmdan koromislo o'rniga polzun o'rnatib, uni ko'zg'almas yo'naltiruvchi bo'ylab xarakatga keltirilsa, u xolda bu mexanizm krivoshil-shatunli mexanizmga aylanadi.

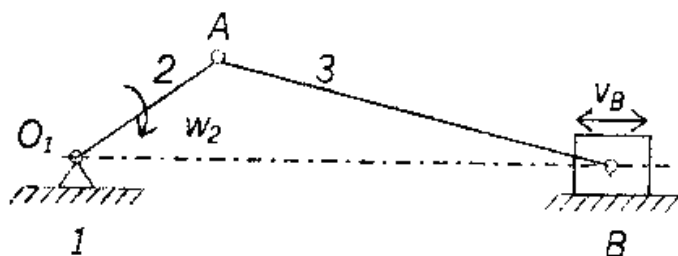

- 1-qo'zg'almas zveno.
- 2-tirsakli val (krivoship).
- 3-shatun.
- 4-polzun.

Kulisali mexanizmlar.

- 1-qo'zg'almas zveno.
- 2-tirsakli val (krivoship).
- 3-tosh.
- 4-kulisa.

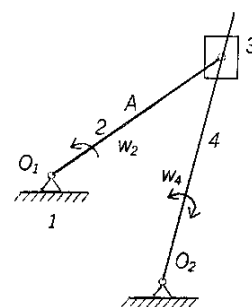

Kulachokli mexanizmlar.

- 1-qo'zg'almas zveno.
- 2-kulachok.
- 3-rolik.
- 4-tolkatel .

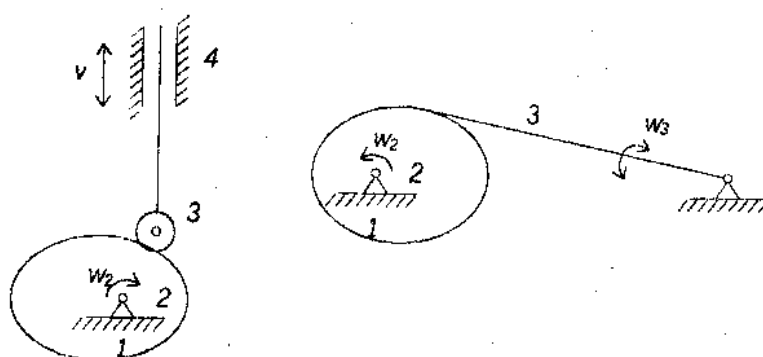

Tishli g'ildirakli mexanizmlar.

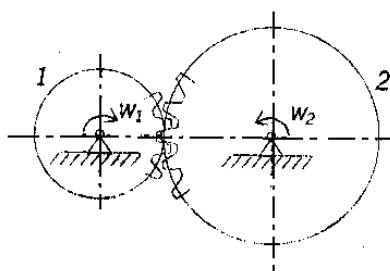

- 1-shesternya.
- 2-g'ildirak.

Vintli mexanizmlar.

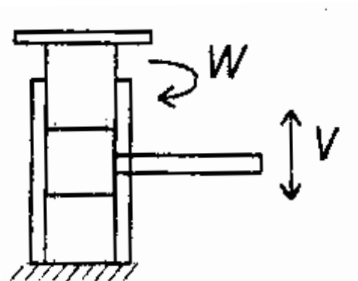

Domkrat misol bo'la oladi.

Friktsion mexanizmlar.

Ishqalanish kuchlari yordami bilan xarakatga keltiruvchi yoki to'xtatiluvchi mexanizmlar friktsion mexanizmlar deb ataladi.

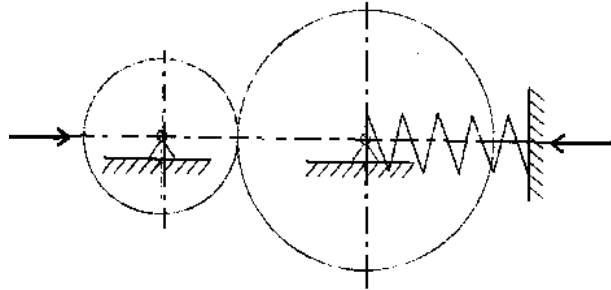

Egiluvchan zvenoli mexanizmlar.

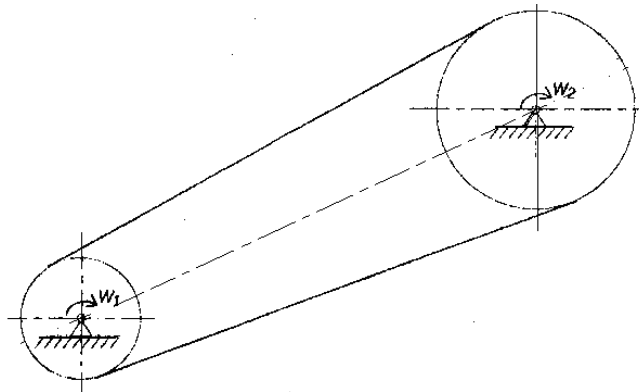

Tasmali uzatmalar, zanjirli uzatmalar.

Gidravlik va pnevmatik mexanizmlar.

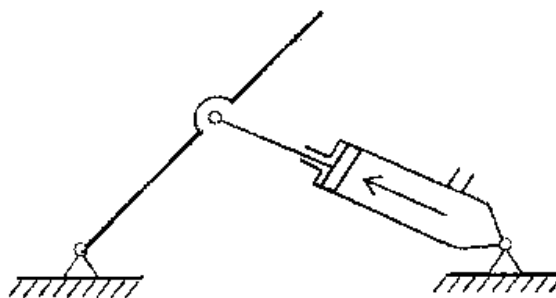

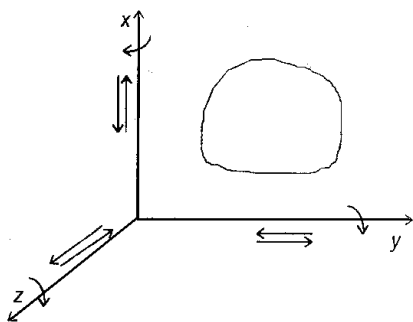

Kinematik juftlar.

Kinematik juft deb ikkita zvenoni bir-biri bilan xarakat qila oladigan qilib biriktirilishiga aytiladi.

Fazoda xarakat qilayotgan xar qanday qattiq jismning erkinlik darajasi 6 ta bo'lib ulardan uchtasi x, y, z o'qlari bo'ylab ilgarilanma xarakatdan, uchtasi esa shu o'qlar atrofida aylanma xarakatdan iborat.

Kinematik juftlar 5 ta sinfga bo'linadi: $S = 6 - N$

bu yerda:

S – bog'lanishlar soni;

N – erkinlik darajasi.

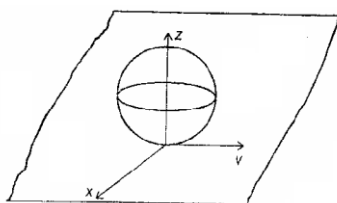

1-sinfga tegishli kinematik juft;

$$S = 6 - 5 = 1$$

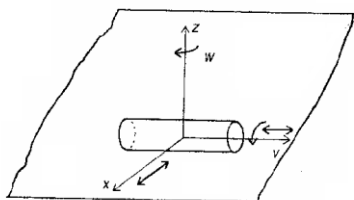

2-sinfga tegishli kinematik juft;

$$S = 6 - 4 = 2$$

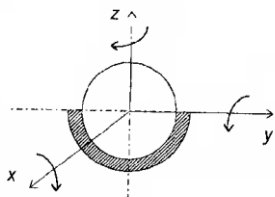

3-sinfga tegishli kinematik juft;

$$S = 6 - 3 = 3$$

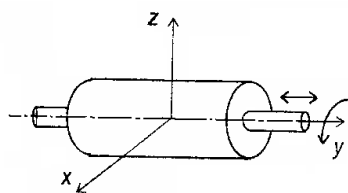

4-sinfga tegishli kinematik juft;

$$S = 6 - 2 = 4$$

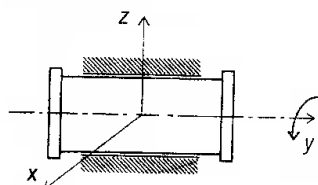

5-sinfga tegishli kinematik juft;

$$S = 6 - 1 = 5$$

Kinematik juft elementlari bir-biriga tekislik yoki sir orkali tegishib tursa, bunday juft quyi kinematik juft deb, agar elementlari nuqta yoki chiziq orqali teginib tursa, bunday juft oliy kinemaatik juft deyiladi.

$$W = 6n - 5P_5 - 4P_4 - 3P_3 - 2P_2 - 1P_1$$

Mexanizmlarning xarakatchanlik (qo'zg'aluvchanlik) darajasi.

Bir necha zvenoning kinematik juftlar vositasi bilan birikishidan (bog'lanishidan) xosil bo'lgan qo'zg'aluvchi sistema kinematik zanjir deb ataladi.

Mexanizmدا n ta zveno bor, 6 ta xarakatchanlikka ega bo'ladi. Fazoviy mexanizmning xarakatchanlik darajasi:

$$W=6n-5P_5-4P_4-3P_3-2P_2-1P_1$$

W—bir zvenoli qo'zg'almas bo'lgan zanjirning qo'zg'aluvchanlik (xarakatlanuvchanlik) darajasi.

n—kinematik zanjirdagi qo'zg'aluvchan (xarakatchan) zvenolar soni.

P_5 — kinematik zanjir tarkibidagi 5 sinfga tegishli kinematik juftlar soni (ularning xar biriga 5 tadan erkinlik darajasini yo'qotadi).

P_4 — kinematik zanjir tarkibidagi 4 sinfga tegishli kinematik juftlar soni (ularning xar biriga 4 tadan bog'lanish qo'yilgan).

P_3 — kinematik zanjir tarkibidagi 3 sinfga tegishli kinematik juftlar soni (ularning xar biriga 3 tadan bog'lanish qo'yilgan).

P_2 — kinematik zanjir tarkibidagi 2 sinfga tegishli kinematik juftlar soni (ularning xar biriga 2 tadan bog'lanish qo'yilgan).

P_1 — kinematik zanjir tarkibidagi 1 sinfga tegishli kinematik juftlar soni (ularning xar biriga 1 tadan bog'lanish qo'yilgan).

Bu formula bir zvenosi qo'zgalmas bo'lgan kinematik zanjirning umumiy xoldagi qo'zg'aluvchanlik formulasi yoki struktura formulasi deb ataladi. Somov – Malo'shev formulasi xam deyiladi.

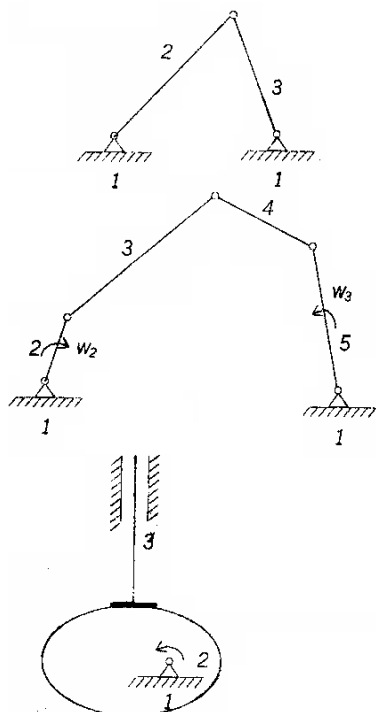

Tekislikda xarakat qiluvchi mexanizmlarning tuzilish formulasi (akad.Chebo'shev formulasi).

Kinematik zanjir tarkibiga kiruvchi qo'zg'almas biror zvenoga nisbatan bir yoki bir necha zveno muayyan tartibda x tartibli xarakatlangan vaqtda zanjirning qolgan zvenolari xam ma'lum tartibli xarakat qilsa, bunday kinematik zanjir *mexanizm* deyiladi.

$$W=3n-2R_5-1R_4$$

W — tekis mexanizmning qo'zg'aluvchanlik darajasi.

n — tekis mexanizm tarkibidagi qo'zg'aluvchi zvenolar soni.

R_5 —5 sinfga tegishli (tekislikdagi 2-sinfga tegishli) kinematik juftlar soni.

R_4 —4 sinfga tegishli (tekislikdagi 1-sinfga tegishli) kinematik juftlar soni.

Misol.

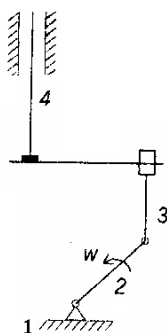

$$W=3n - 2R_5 - 1R_4$$

$$n=3; R_5=4; R_4=1$$

$$W=3 \cdot 3 - 2 \cdot 4 - 1 = 1$$

Bu mexanizmning qo'zg'aluvchanlik darajasi 1 ga teng.

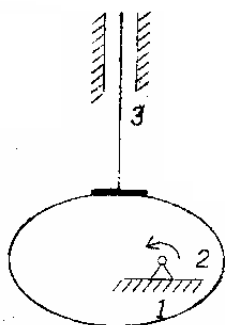

$$n=3; R_5=4; R_4=0 \quad W=3 \cdot 3 - 2 \cdot 4 = 1$$

$$n=2; R_5=3; P_4=0 \quad W=3 \cdot 2 - 2 \cdot 3 = 0$$

demak bu mexanizm emas, xarakat bo'lmaydi, ya'ni ferma, bikr sistema.

$$n=4; R_5=5; R_4=0 \quad W=3 \cdot 4 - 2 \cdot 5 = 2$$

$$n=2; R_5=2; R_4=1$$

$$W=3 \cdot 2 - 2 \cdot 2 - 1 = 1$$

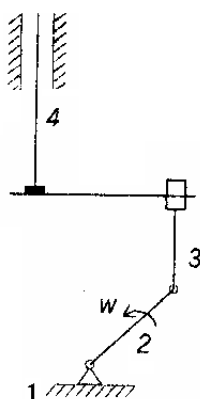

Bu mexanizm qo'zg'aluvchanlik darajasi 1 ga teng bo'lgan kulachokli mexanizmdir va unga ekvivalent bo'lgan krivoship-shatunli mexanizmdir.

NAZORAT SAVOLLARI

1. Mexanizmlarning qanday turlari bor?
2. Mexanizmlarning strukturasi. Kinematik juftlar necha sinfga bo'linadi?
3. Kinematik juftlar nechta turga bo'linadi?
4. Oily kinematik juftlar qanday aniqlanadi?
5. Quyi kinematik juftlar qanday aniqlanadi?
6. 5-sinf kinematik juftlar qanday aniqlanadi?

Tayanch so'z va iboralar

Richagli mexanizmlar, kulachakli mexanizmlar, shesternyali, mexanizmlar, vintli mexanizmlar, friksion mexanizmlar, egiluvchan zvenoli mexanizmlar, gidravlik va pnevmatik mexanizmlar, elektrik mexanizmlar, kinematik juft, bog'lanishlar soni, erkinlik darajasi, mexanizmlarning xarakatchanlik darajasi, kinematik zanjir, krivoship – shatunli mexanizm.

