

Services Marketing

Mamurjon Rahimov
mrahimov@wiut.uz
mamurjon@gmail.com

Service Innovation and Design (Chapter 8)

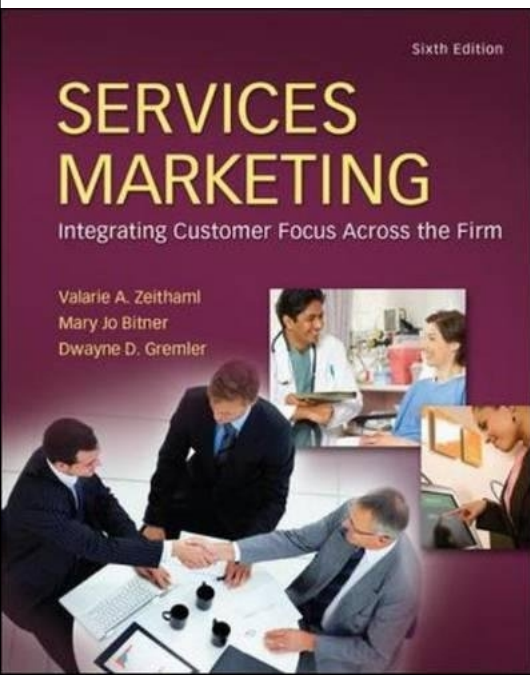

Service Innovation

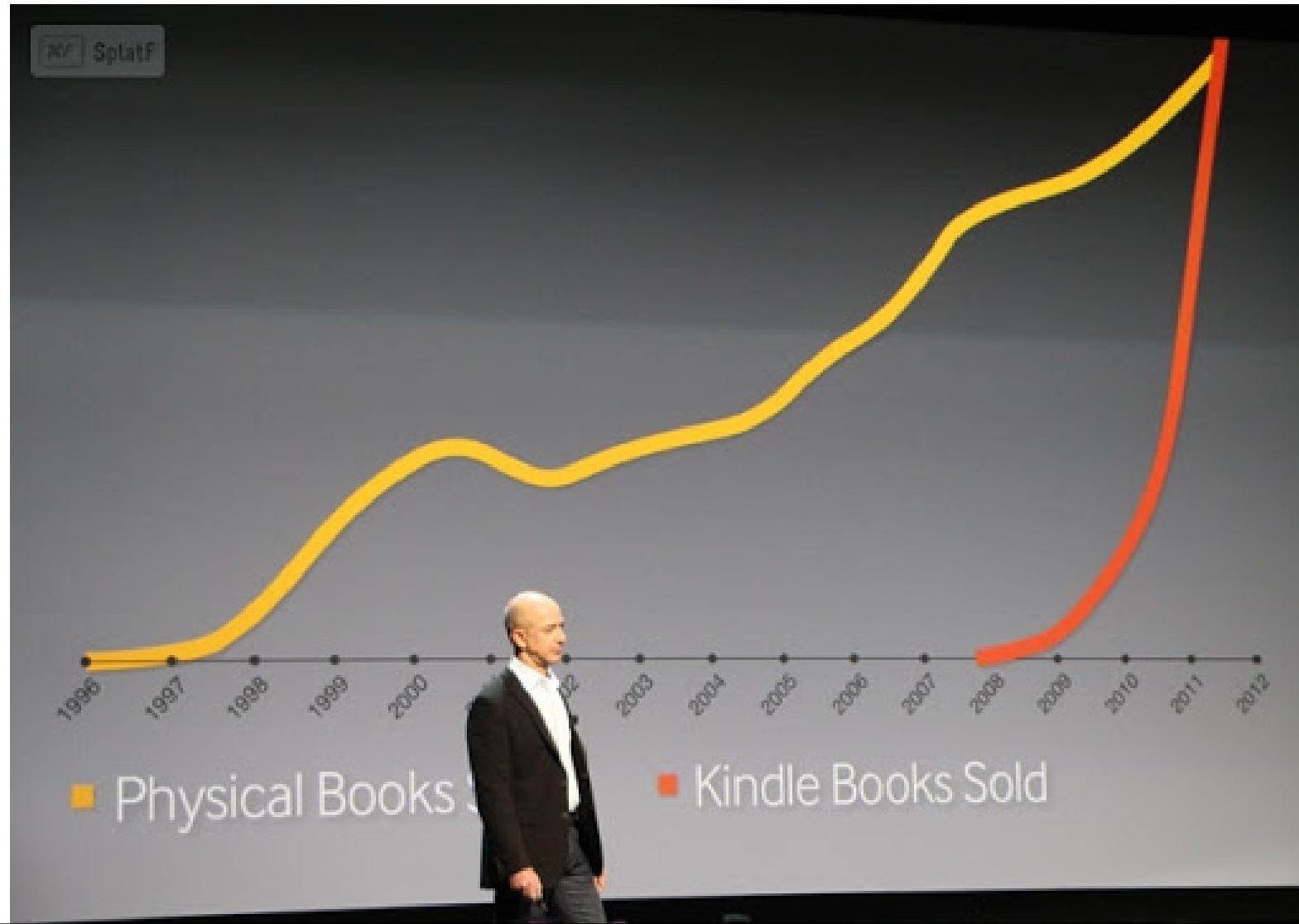

Service Innovation - Kindle is a service!

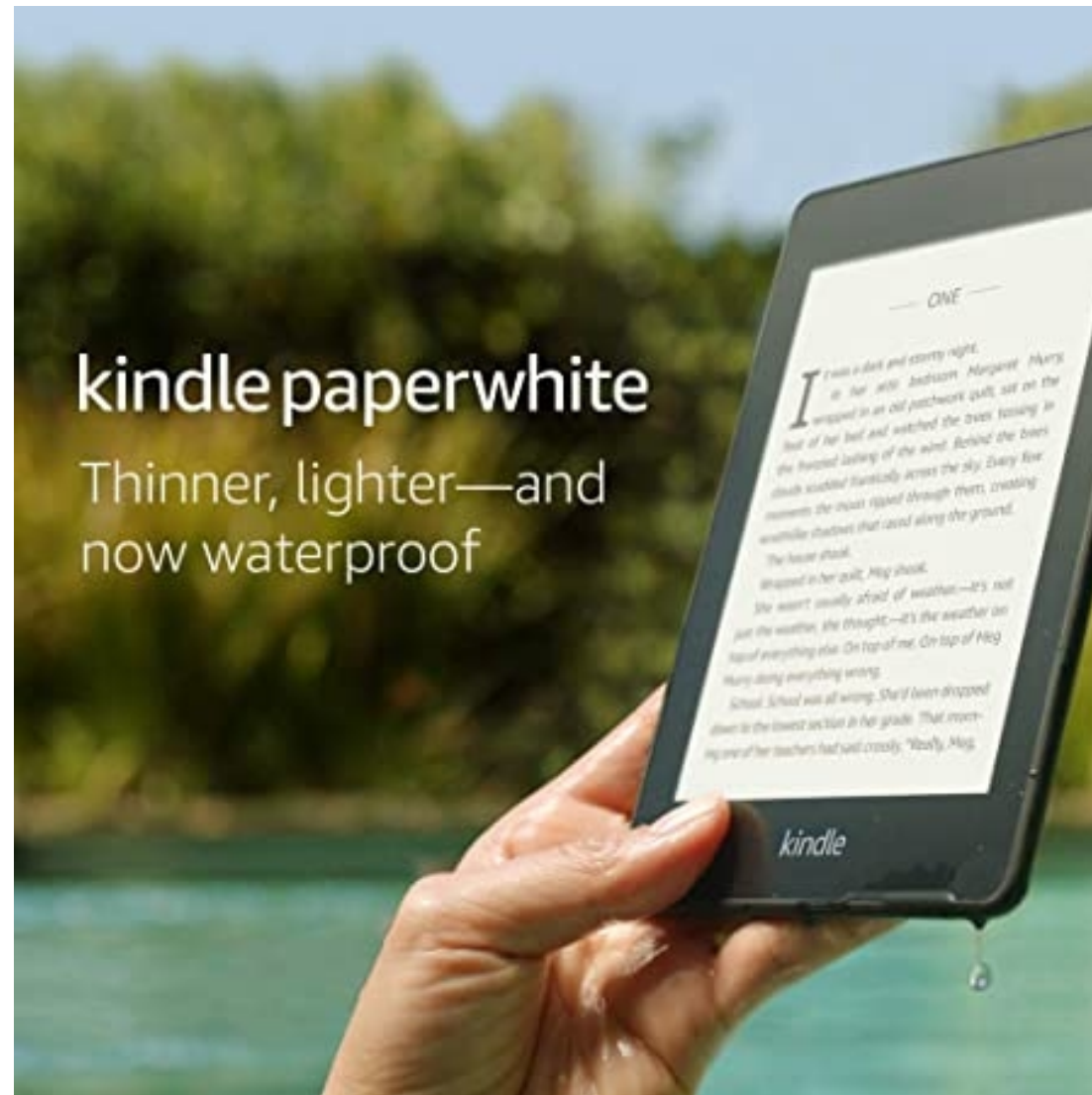

kindle paperwhite

Thinner, lighter—and
now waterproof

Objectives for Chapter 8: Service Development and Design

- Describe the challenges inherent in service design
- Present steps in the new service development process
- Show the value of service blueprinting and quality function deployment (QFD) in new service design and service improvement
- Present lessons learned in choosing and implementing high-performance service innovations

Amazon keeps innovating...

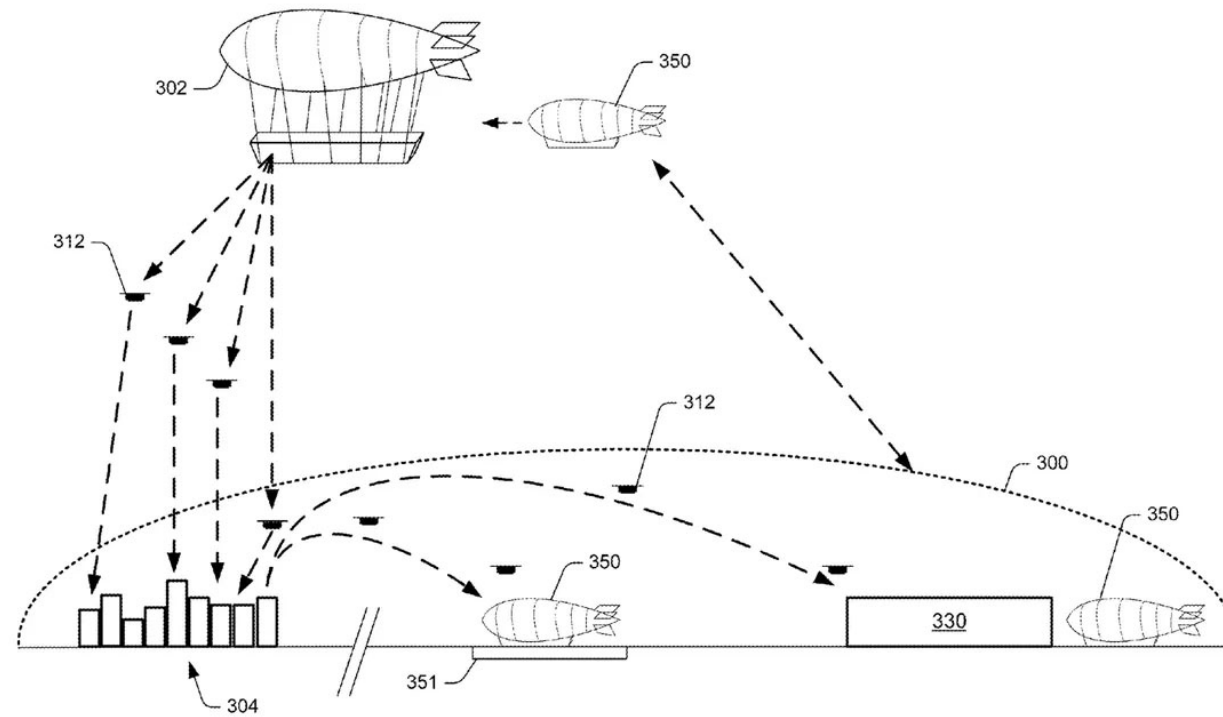

FIG. 3

From: "Primed for Disruption: 12 Wacky Amazon Patents Fueling the Future of Fulfillment"

Amazon keeps innovating...



THE GAPS MODEL OF SERVICE QUALITY

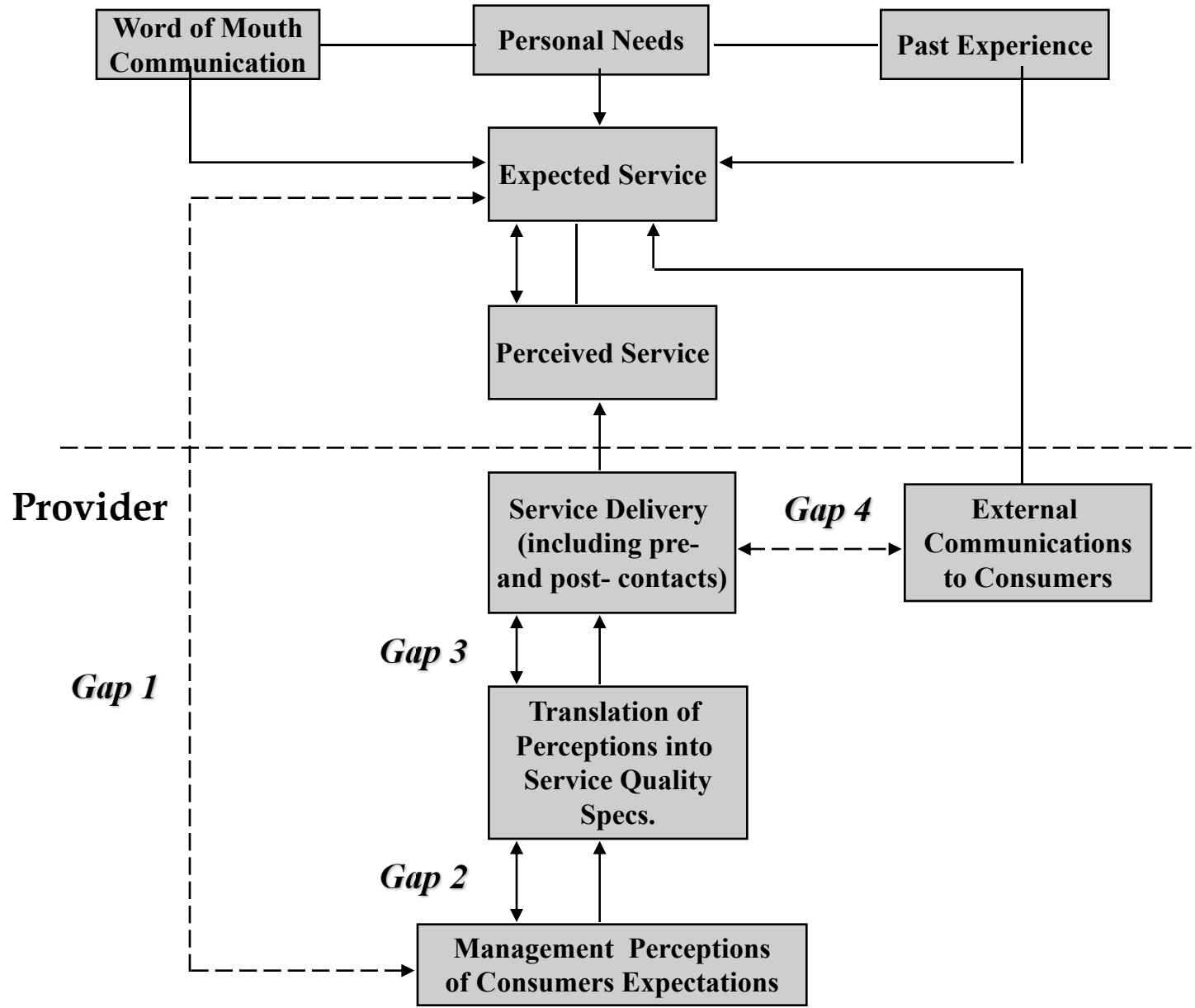

THE GAPS MODEL OF SERVICE QUALITY

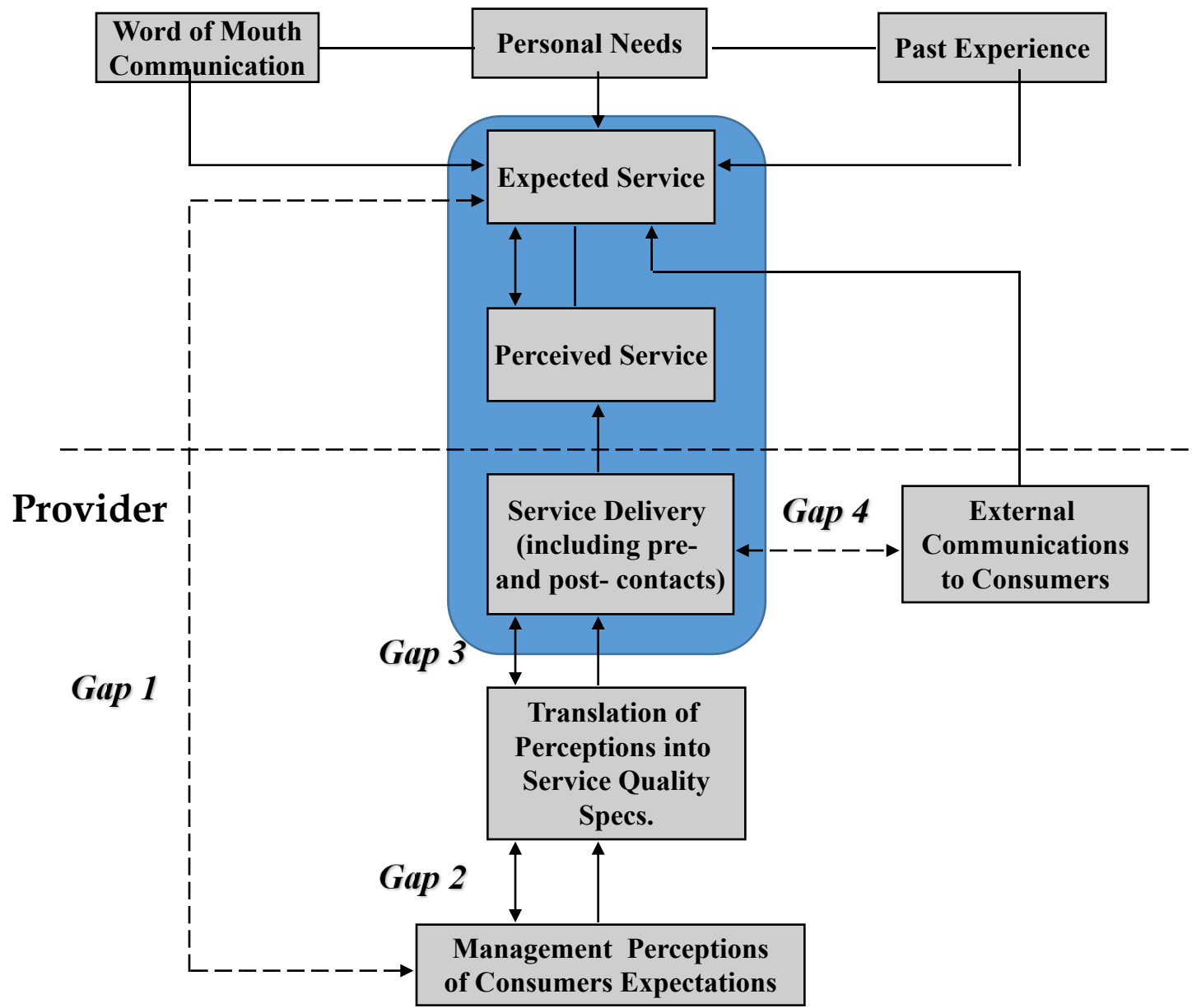

Risks of Relying on Words Alone to Describe Services

- **Oversimplification**
- **Incompleteness**
- **Subjectivity**
- **Biased Interpretation**



New Service Development Process

Front End
Planning

Business Strategy Development or Review

New Service Strategy Development

Idea Generation

Screen ideas against new service strategy

Concept Development and Evaluation

Test concept with customers and employees

Business Analysis

Test for profitability and feasibility

Service Development and Testing

Conduct service prototype test

Market Testing

Test service and other marketing-mix elements

Commercialization

Postintroduction Evaluation

Implementation



New Service Strategy Matrix for Identifying Growth Opportunities

Offerings	Markets	
	Current Customers	New Customers
Existing Services	SHARE BUILDING	MARKET DEVELOPMENT
New Services	SERVICE DEVELOPMENT	DIVERSIFICATION

New Service Strategy Matrix for Identifying Growth Opportunities - based on Ansoff's Matrix (that you may remember)

	Existing Products	New Products
Existing Market	Market Penetration	Product Development
New Market	Market Development	Diversification

Service Mapping/Blueprinting

- A tool for simultaneously depicting the service process, the points of customer contact, and the evidence of service from the customer's point of view.

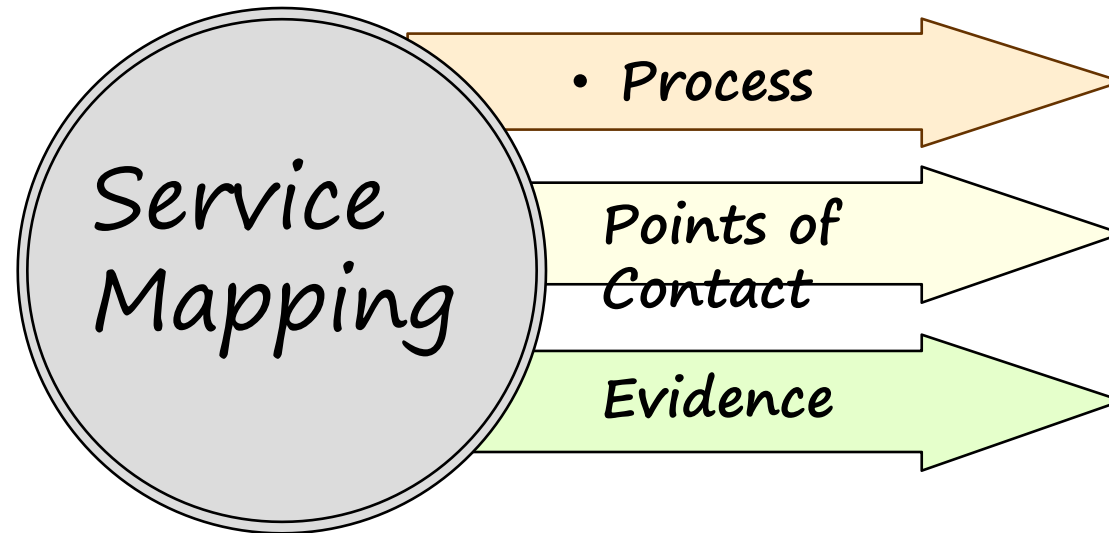

The essence of service mapping



Service Blueprint Components

CUSTOMER ACTIONS

line of interaction

“ONSTAGE” CONTACT EMPLOYEE ACTIONS

line of visibility

“BACKSTAGE” CONTACT EMPLOYEE ACTIONS

line of internal interaction

SUPPORT PROCESSES

Customer actions

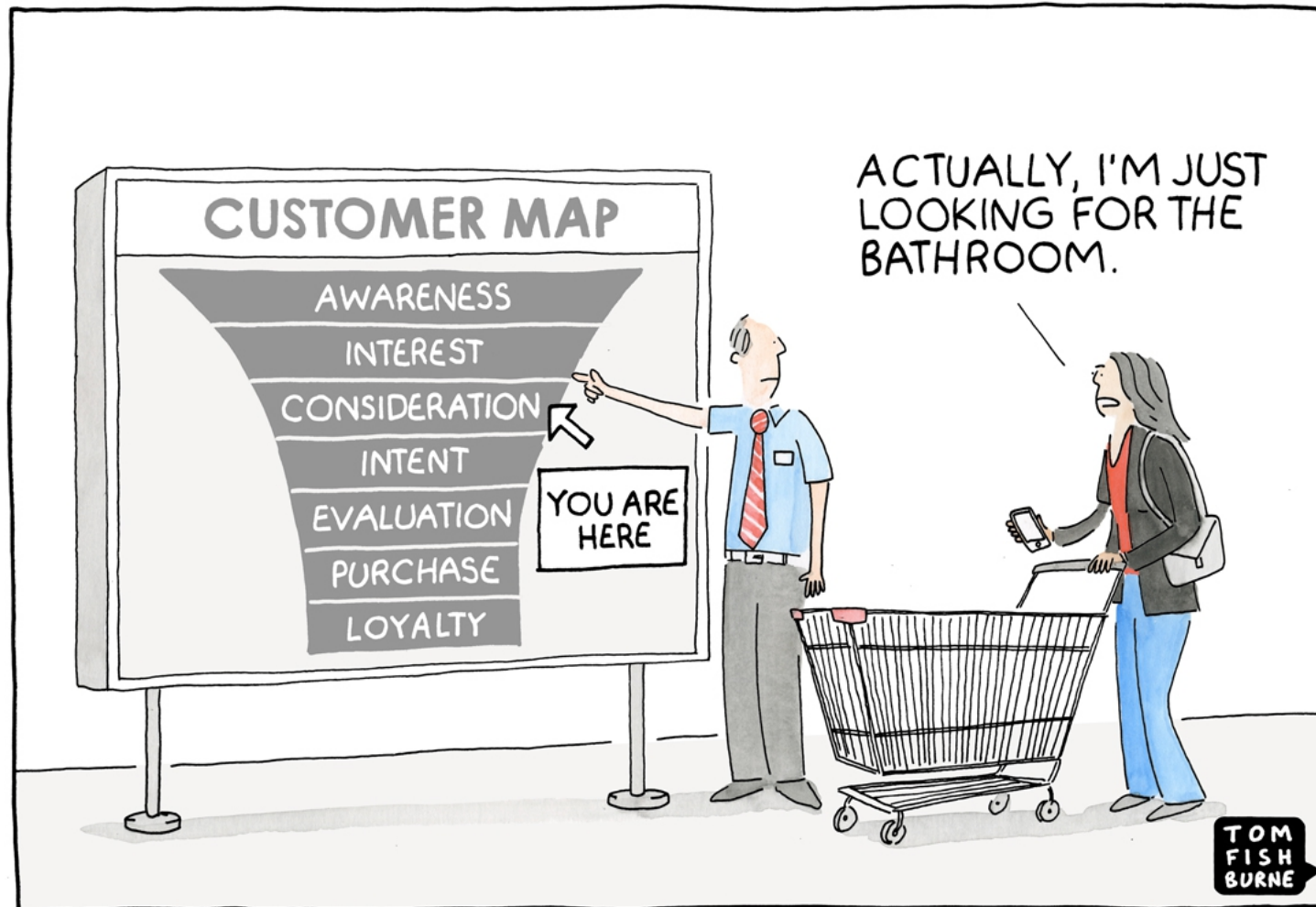

“ONSTAGE” contact employee actions



“Backstage” contact employee actions



Express Mail Delivery Service

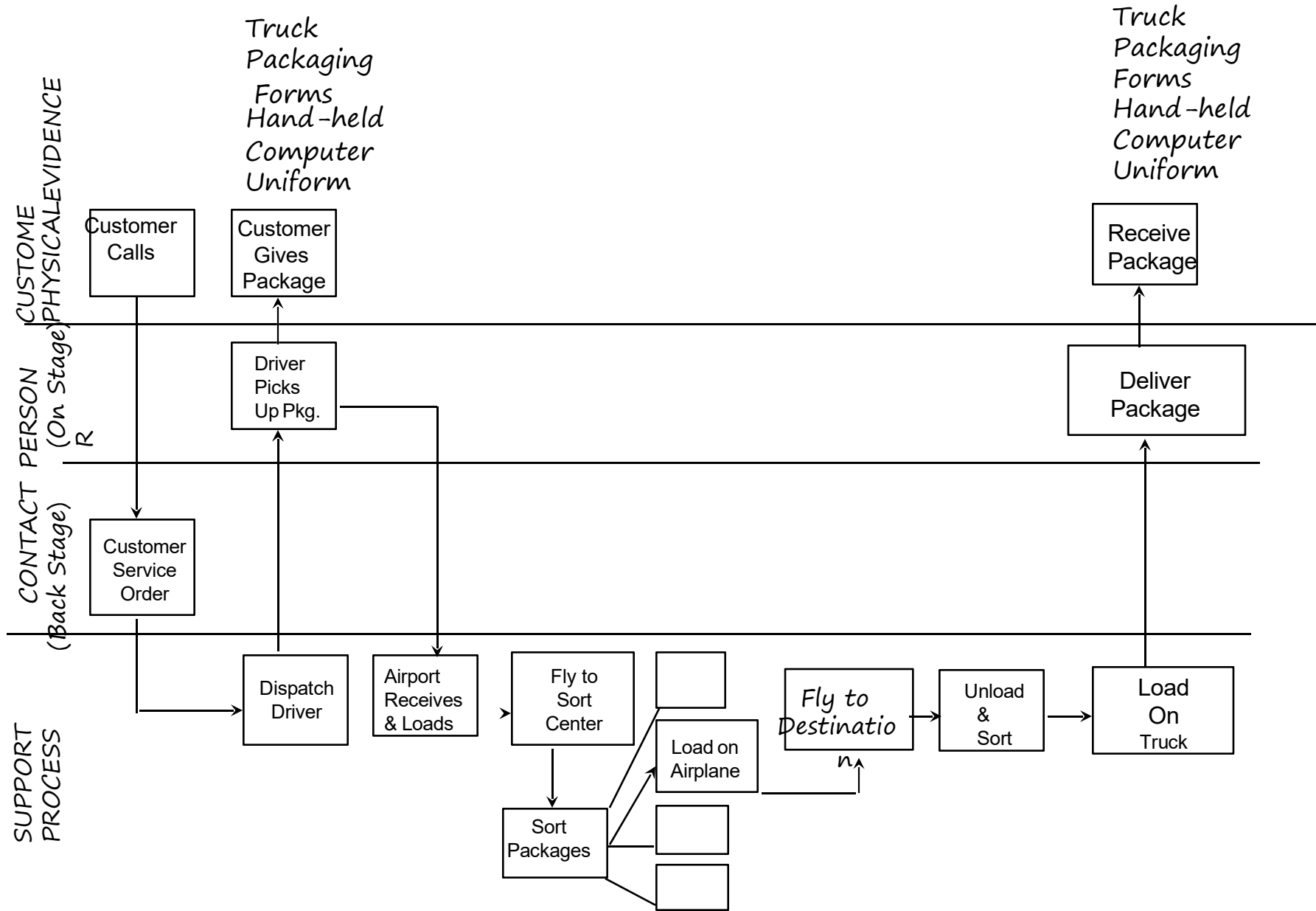

Express Mail Delivery Service



Overnight Hotel Stay

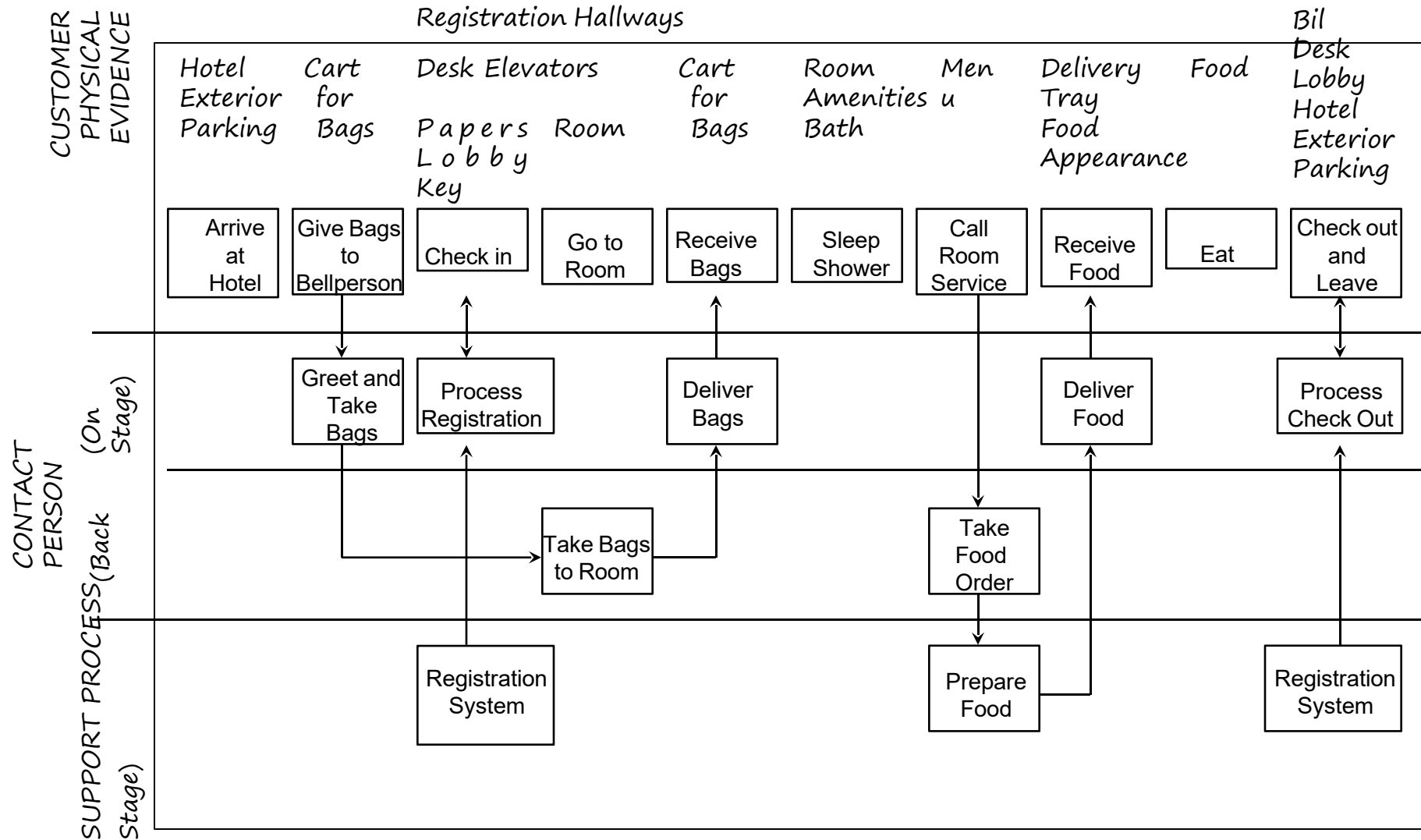

Overnight Hotel Stay - what customers see



Building a Service Blueprint

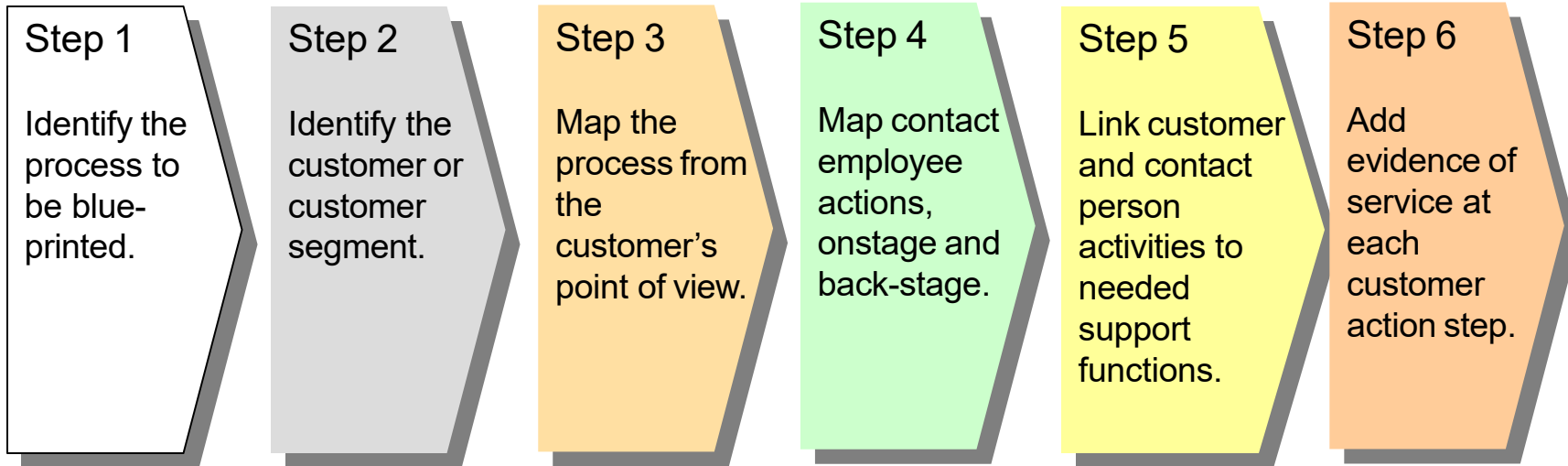

Building a Service Blueprint - Human Touch Needed



Application of Service Blueprints

- **New Service Development**
 - concept development
 - market testing
- **Supporting a “Zero Defects” Culture**
 - managing reliability
 - identifying empowerment issues
- **Service Recovery Strategies**
 - identifying service problems
 - conducting root cause analysis
 - modifying processes

Blueprints Can Be Used By:

- **Service Marketers**
 - creating realistic customer expectations
 - service system design
 - promotion
- **Human Resources**
 - empowering the human element
 - job descriptions
 - selection criteria
 - appraisal systems
- **Operations Management**
 - rendering the service as promised
 - managing fail points
 - training systems
 - quality control
- **System Technology**
 - providing necessary tools:
 - system specifications
 - personal preference databases

References:

- **Textbook:** Zeithaml, Valarie, Mary Jo Bitner, and Dwayne Gremler (2013), **Services Marketing** 6th International Edition, Irwin/McGraw-Hill Publishing. (Other editions will also work, but you are responsible to compare your edition to the 6th - because the syllabus was written for the 6th edition.)
- Amazon Kindle Growth Chart - <http://www.fromedome.com/2011/09/kindle-growth-chart/>
- Printed cases will be provided each week and also will be posted on the Module Intranet page prior to seminars.

**THANK YOU FOR YOUR
ATTENTION!**



WESTMINSTER

INTERNATIONAL UNIVERSITY IN TASHKENT

