

# Lecture 12: Nodal Analysis with Voltage Sources

## Voltage Source Connected to the Reference Node

This case is illustrated by an example.

### Example 1:

Calculate the nodal voltages  $V_1$ ,  $V_2$ ,  $V_3$ .

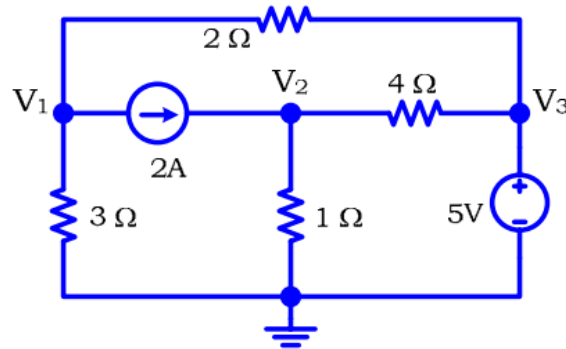

Figure 1

Solution:

Nodes 1 & 2  $\Rightarrow$  No voltage sources connected  $\Rightarrow$  No special treatment

Node 3  $\Rightarrow$  Voltage source connected  $\Rightarrow$  Needs special treatment

$$\text{KCL at node 1} \Rightarrow \frac{V_1 - 0}{3} + 2 + \frac{V_1 - V_3}{2} = 0 \quad \Rightarrow \quad 5V_1 - 3V_3 = -6 \quad (1)$$

$$\text{KCL at node 2} \Rightarrow -2 + \frac{V_2 - 0}{1} + \frac{V_2 - V_3}{4} = 0 \quad \Rightarrow \quad 5V_2 - V_3 = 8 \quad (2)$$

$$\text{KCL at node 3} \Rightarrow \frac{V_3 - V_2}{4} + \frac{V_3 - V_1}{2} + i_x = 0 \quad (\text{problem!})$$

$i_x$  cannot directly be replaced with nodal voltages, because *Ohm's Law does not apply to voltage sources*.

We have three unknowns ( $V_1$  &  $V_2$  &  $V_3$ )  $\Rightarrow$  we need 3 equations  $\Rightarrow$  1 equation is missing!

For node 3, the basic Nodal Analysis procedure *must be* revised.

# Lecture 12: Nodal Analysis with Voltage Sources

The  $5V$  source is connected to the reference node

⇓

$$KVL \Rightarrow V_3 - 0 = 5 \Rightarrow V_3 = 5 \quad (3)$$

The missing 3<sup>rd</sup> equation is *easy* to obtain, using **KVL** between node 3 and the reference node.

$$5V_1 - 3V_3 = -6 \quad (1) \quad \text{Using the regular Nodal Analysis procedure}$$

$$5V_2 - V_3 = 8 \quad (2) \quad \text{Using the regular Nodal Analysis procedure}$$

$$V_3 = 5 \quad (3) \quad \text{Using KVL}$$

$$\text{Solving the above set} \Rightarrow V_1 = 1.8V \quad \& \quad V_2 = 2.6V \quad \& \quad V_3 = 5V$$

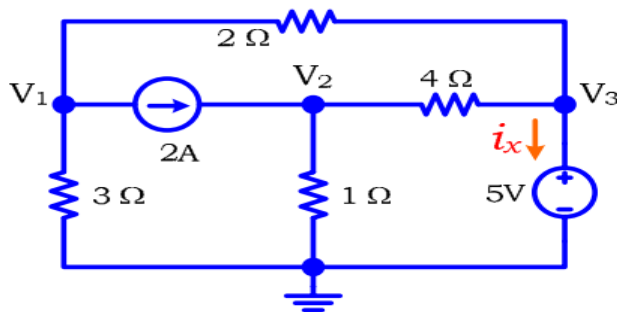

**Figure 2**

Voltage source connected to reference  $\Rightarrow$  Use KVL only (do not use KCL)

## Voltage Source *not* Connected to the Reference Node

### Example 2:

Calculate the nodal voltages  $V_1$ ,  $V_2$ ,  $V_3$ .

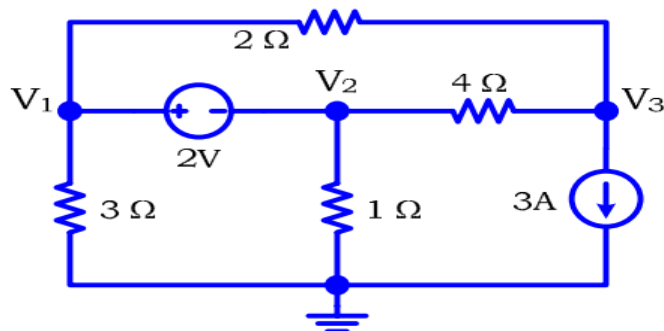

**Figure 3**

## Lecture 12: Nodal Analysis with Voltage Sources

Solution:

$$\text{KCL at node 1} \Rightarrow \frac{V_1 - 0}{3} + i_x + \frac{V_1 - V_3}{2} = 0 \Rightarrow \text{(problem!)}$$

$$\text{KCL at node 2} \Rightarrow -i_x + \frac{V_2}{1} + \frac{V_2 - V_3}{4} = 0 \Rightarrow \text{(another problem!)}$$

The 2V source is connected to nodes 1 & 2  $\Rightarrow$  KCL at nodes 1 & 2 contains  $i_x$

We need two equations, one equation for each node.

How should we proceed now?

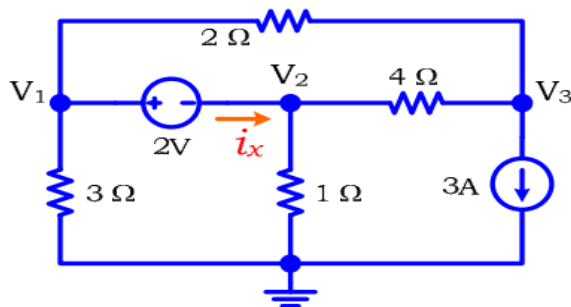

Figure 4

1) Draw a super node around nodes 1 & 2

$$2) \text{ KCL at the super node} \Rightarrow \frac{V_1 - 0}{3} + \frac{V_2 - 0}{1} + \frac{V_2 - V_3}{4} + \frac{V_1 - V_3}{2} = 0 \quad (\text{Avoids } i_x)$$

$\Downarrow$

$$10V_1 + 9V_2 - 3V_3 = 0 \quad (1)$$

$$3) \text{ KVL} \Rightarrow V_1 - V_2 = 2 \quad (2)$$

We obtained the required number of equations.

$$\text{KCL at node 3} \Rightarrow \frac{V_3 - V_2}{4} + 3 + \frac{V_3 - V_1}{2} = 0 \Rightarrow -2V_1 - V_2 + 3V_3 = -24 \quad (3)$$

$$\text{Solving (1), (2) \& (3)} \Rightarrow V_1 = -0.5V \quad \& \quad V_2 = -2.5V \quad \& \quad V_3 = -9.17V$$

## Lecture 12: Nodal Analysis with Voltage Sources

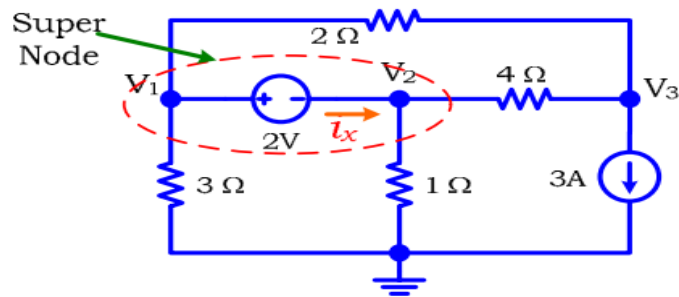

Figure 5

Voltage source *not* connected to reference  $\Rightarrow$  KCL at super node & KVL

### Intersecting Super Nodes

#### Example 3:

Calculate the nodal voltages  $V_1$ ,  $V_2$ ,  $V_3$ .

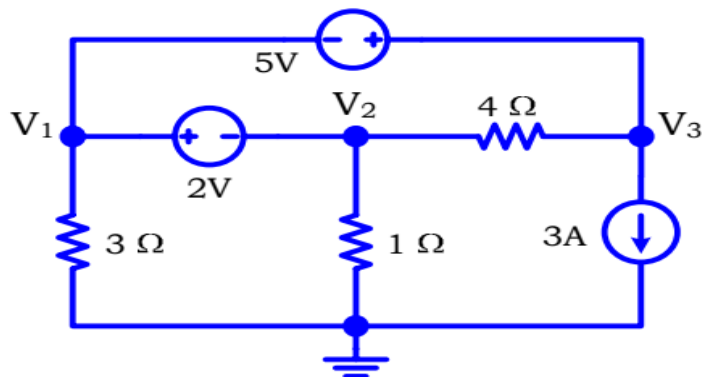

Figure 6

Solution:

Nodes 1 & 2 are connected by the 2V source  $\Rightarrow$  draw super node 1

Nodes 1 & 3 are connected by the 5V source  $\Rightarrow$  draw super node 2

If we apply KCL at super node 1  $\Rightarrow$  KCL contains current through the 5V source!

If we apply KCL at super node 2  $\Rightarrow$  KCL contains current through the 2V source!

Do not apply KCL at nodes 1 or 2.

## Lecture 12: Nodal Analysis with Voltage Sources

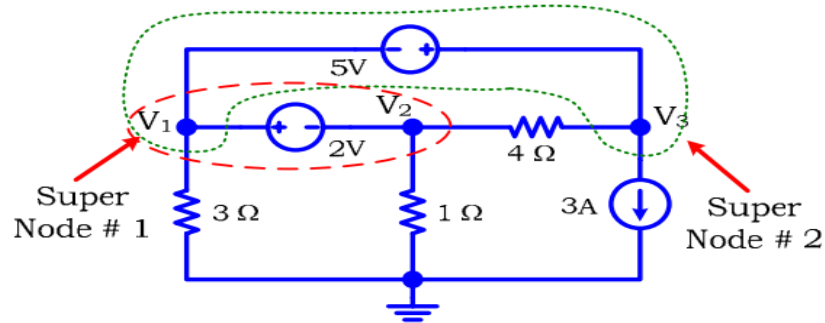

Figure 7

Combine the two super nodes into a single super node.

KCL at the new super node

⇓

$$\frac{V_1 - 0}{3} + \frac{V_2 - 0}{1} + \frac{V_2 - V_3}{4} + \frac{V_3 - V_2}{4} + 3 = 0$$

⇓

$$\frac{V_1 - 0}{3} + \frac{V_2 - 0}{1} + 3 = 0 \quad (\text{actual current through } 4\Omega \text{ leaves and enters the super node})$$

⇓

$$V_1 + 3V_2 = -9 \quad (1)$$

To obtain the remaining two equations  $\Rightarrow$  Apply KVL

$$\text{KVL} \Rightarrow V_1 - V_2 = 2 \quad (2)$$

$$\text{KVL} \Rightarrow V_1 - V_3 = 5 \quad (3)$$

$$\text{Solving (1) \& (2) \& (3)} \Rightarrow V_1 = -0.75V \quad \& \quad V_2 = -2.75V \quad \& \quad V_3 = -5.75V$$

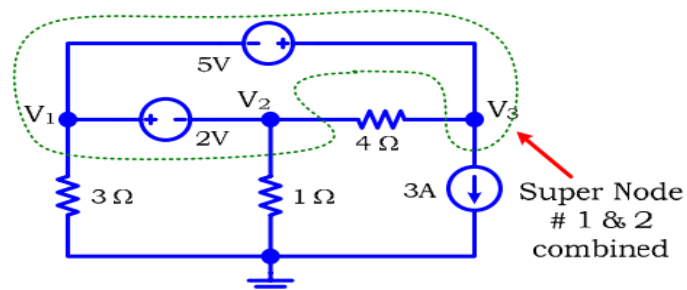

# Lecture 12: Nodal Analysis with Voltage Sources

**Figure 8**

Every voltage source provides one nodal equation using KVL

Strategy A



- 1) Apply KVL to *every* voltage source
- 2) If two super nodes intersect  $\Rightarrow$  *join them*
- 3) Apply KCL at a node, super node, or combined super node (*only as necessary*)

Let us apply strategy A to the next example.

**Example 4:**

Write down the nodal equations (do not simplify and do not solve).

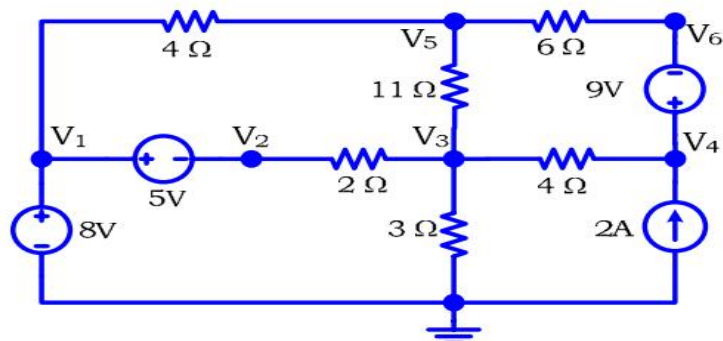

**Figure 9**

Solution:

KVL for every voltage source  $\Rightarrow$

$$V_1 = 8 \quad (1)$$

$$V_1 - V_2 = 5 \quad (2)$$

$$V_4 - V_6 = 9 \quad (3)$$

Three more equation required  $\Rightarrow$  Apply KCL

(We *already* obtained *two* equations from nodes 1 & 2  $\Rightarrow$  No KCL at nodes 1 & 2)

## Lecture 12: Nodal Analysis with Voltage Sources

$$\text{KCL at node 3} \Rightarrow \frac{V_3 - V_2}{2} + \frac{V_3}{3} + \frac{V_3 - V_4}{4} + \frac{V_3 - V_5}{11} = 0 \Rightarrow (4)$$

$$\text{KCL at node 5} \Rightarrow \frac{V_5 - V_1}{4} + \frac{V_5 - V_3}{11} + \frac{V_5 - V_6}{6} = 0 \Rightarrow (5)$$

One more equation is required!

$$\text{KCL at super node} \Rightarrow \frac{V_4 - V_3}{4} - 2 + \frac{V_6 - V_5}{6} = 0 \Rightarrow (6)$$

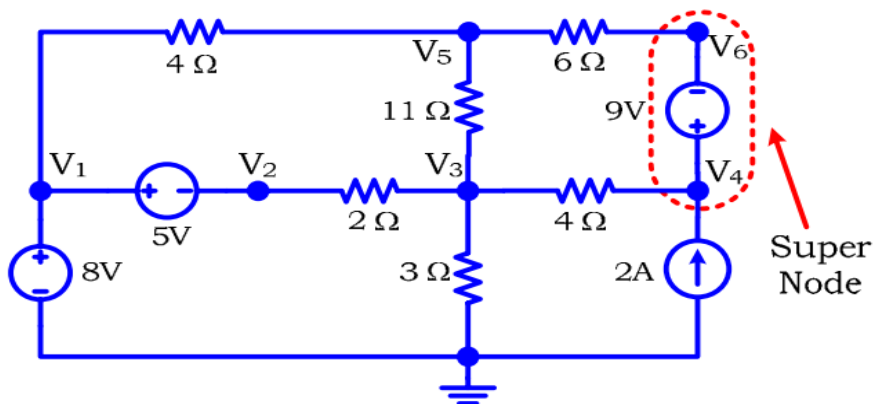

Figure 10

In the previous example, we *did not* apply KCL at the S.N. 1, or S.N. 2 because we *do not need* KCL there (since we have enough equations from nodes 1 & 2).

Another way to think about this point:

S. N. 1 contains current through the 8V source  $\Rightarrow$  Do not apply KCL at S.N. 1

S. N. 2 contains current through the 5V & 8V sources  $\Rightarrow$  Do not apply KCL at S.N. 2

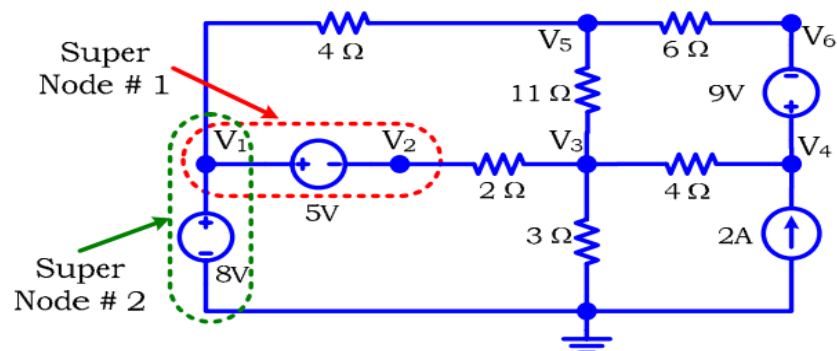

Figure 11

## Lecture 12: Nodal Analysis with Voltage Sources

Combine S.N. 1 & 2 into a new S.N.

The new S.N. *still* contains current through the 8V source  $\Rightarrow$  Do not apply KCL at the new S.N.!!

The *basic* reason for this is that the new S.N. contains the *reference* node.

IMPORTANT



Super node contains the *reference* node  $\Rightarrow$  Do not apply KCL

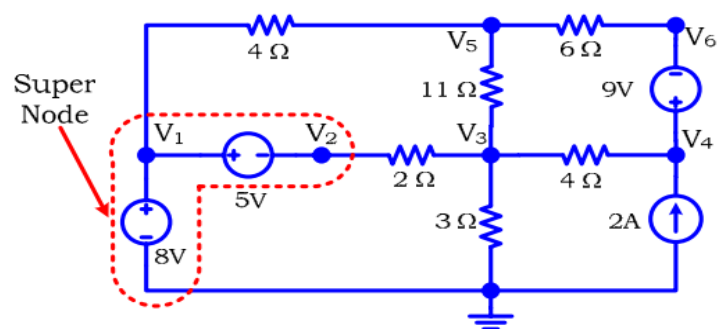

Figure 12

Strategy B



- 1) Apply KVL to *every* voltage source
- 2) Draw a super node around *every* voltage source
- 3) If two super nodes intersect  $\Rightarrow$  *join them*
- 4) Do *not* apply KCL to *any* super node that contains the *reference* node
- 5) Apply KCL to the remaining nodes and super nodes

Strategies A and B are *basically* the same, they produce *exactly* the same set of equations.