

Lecture 10: Norton Equivalent Circuits and Maxm. Power

Calculation of TEC (Method 3):

Recall method 1: 1) Find $V_{th} = V_{oc}$ 2) Find $R_{th} = \frac{V_{oc}}{i_{sc}}$

The *first* step in method 3 is the *same as in method 1*, we first find $V_{th} = V_{oc}$.

To find R_{th} method 3 uses a *different* technique, as explained next:

1) Set *all independent* sources in circuit A to zero [leave dependent sources as they are]

2) Calculate $R_{eq} = R_{th}$

[the equivalent resistance *after all independent* sources have been set to zero is equal to the Thevenin's resistance]

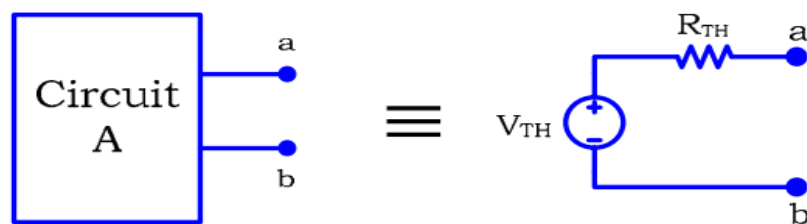

Figure 1

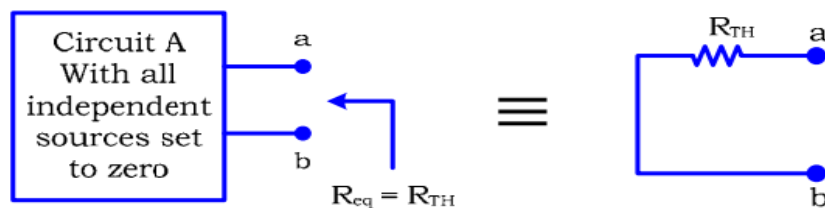

Figure 2

To set an *independent voltage* source to zero \Rightarrow replace it with a *short* circuit

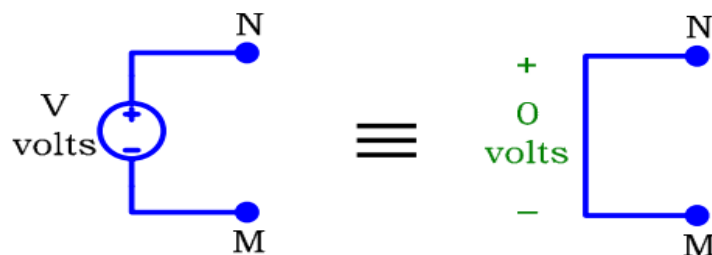

Figure 3

To set an *independent current* source to zero \Rightarrow replace it with an *open* circuit

Lecture 10: Norton Equivalent Circuits and Maxm. Power

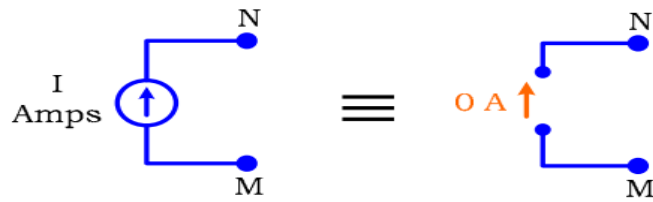

Figure 4

Example 1:

Calculate the TEC.

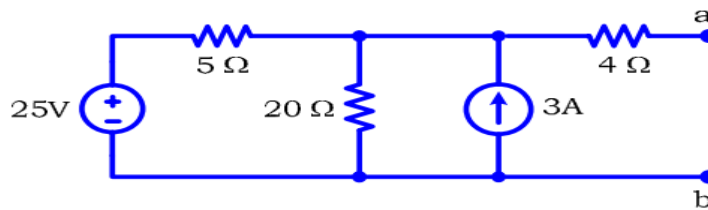

Figure 5

Solution:

Calculate $V_{th} = V_{oc}$ [Let us use the mesh analysis, since there is only *one actual* unknown]

$i_3 = 0$ [because of the open circuit]

$\therefore i_2 = -3$

KVL around mesh 1 $\Rightarrow -25 + 5i_1 + 20(i_1 - (-3)) = 0 \Rightarrow i_1 = -1.4A$

KVL around the outer circuit $\Rightarrow -25 + 5(-1.4) + 4(0) + V_{oc} = 0 \Rightarrow V_{oc} = 32V$

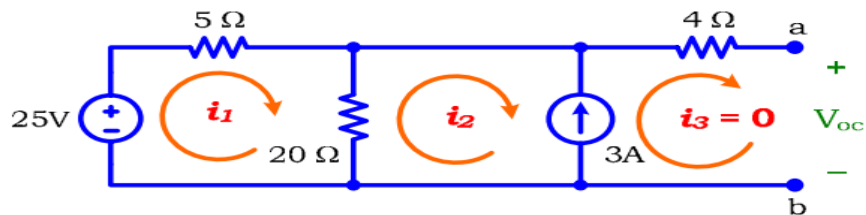

Figure 6

To find R_{th} :

Set *all independent* sources to zero

3A \Rightarrow replace with an *open* circuit

Lecture 10: Norton Equivalent Circuits and Maxm. Power

$25V \Rightarrow$ replace with a *short* circuit

Calculate $R_{eq} = R_{th}$

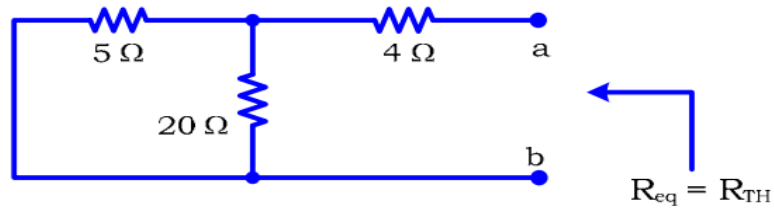

Figure 7

$$5\Omega \parallel 20\Omega \Rightarrow 4\Omega$$

$$\therefore R_{eq} = R_{th} = 4 + 4 = 8\Omega$$

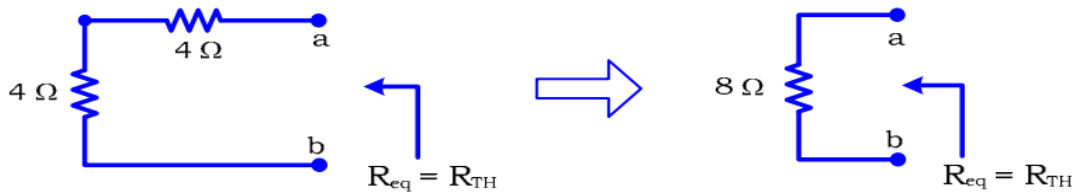

Figure 8

The resulting TEC is:

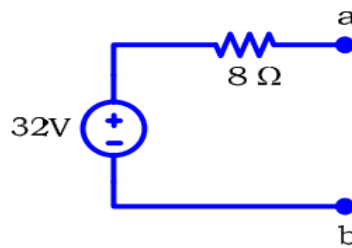

Figure 9

The Norton Equivalent Circuit:

Instead of representing circuit A with a voltage source in series with a resistor, we can represent it with a current source in parallel with a resistor.

The is called Norton Equivalent Circuit (NEC)

In general, the TEC & NEC circuits are related by source transformation. Then:

Lecture 10: Norton Equivalent Circuits and Maxm. Power

- 1) The values of the resistances in the TEC & NEC are the same.
- 2) Using source transformation, the current source I in the NEC is given by:

$$I = \frac{V_{th}}{R_{th}} \text{ [the same as the short circuit current]}$$

$$\therefore I = \frac{V_{th}}{R_{th}} = I_{sc}$$

In general:

We know the TEC \Leftrightarrow We Know the NEC

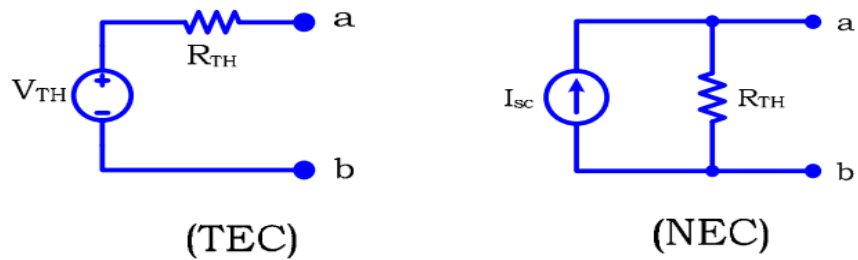
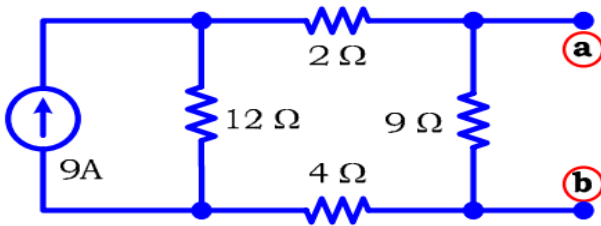

Figure 16

Example1:

Find the Norton Equivalent Circuit with respect to the terminals a, b for the circuit



Solution:

Using source transformation: $V=9 \times 12=108 \text{ V}$

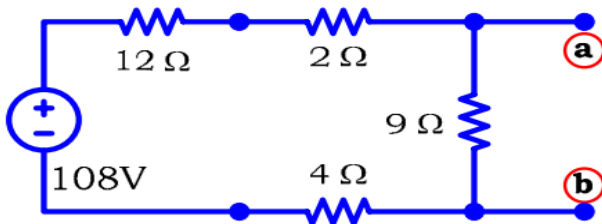

Combine series resistors $12 + 2 + 4 = 18 \text{ Ohms}$

Lecture 10: Norton Equivalent Circuits and Maxm. Power

Draw circuit again $V=108\text{ V}$ in series with 18 Ohms

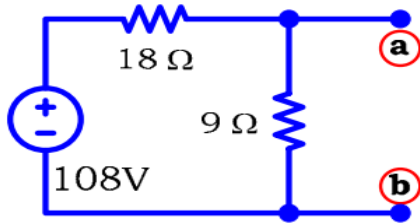

ST again: $I=V/R$ $I=108/18=6\text{A}$

Draw Circuit $6\text{A}(\text{up})$ in // to $18 // 9$

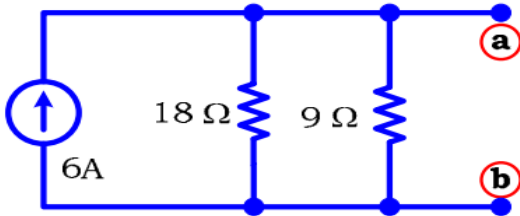

Combine series resistors $18 // 9 = 6\text{ Ohms}$

Draw Circuit $6\text{A}(\text{up})$ in // to 6 Ohms

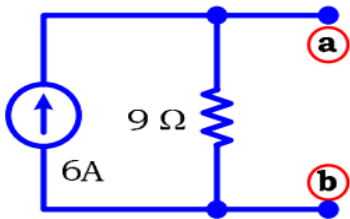

Therefore NEC:

$I_N=6\text{A}$

$R_N=6\text{Ohms}$

Example2:

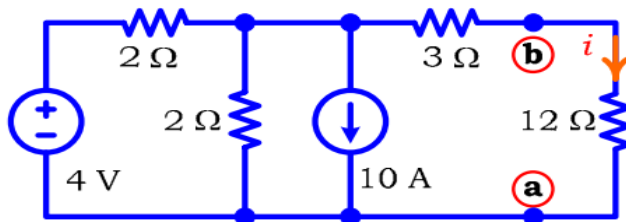

Determine the current I in the circuit by reducing the circuit attached to the $12-\Omega$ resistor to a TE. Find the NEC.

Solution:

Remove $12-\Omega$ resistor mark V_{oc}

Lecture 10: Norton Equivalent Circuits and Maxm. Power

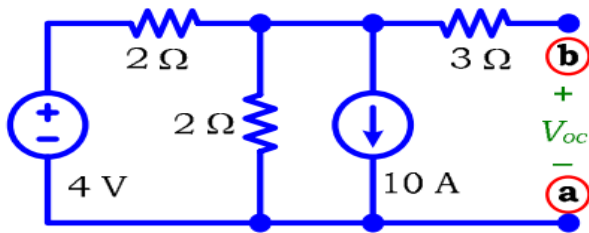

To find V_{th} let us determine V_{oc}

Using ST for the source of 4v in series with $2-\Omega$ resistor we get: $I=2A$ (up) // $2-\Omega$

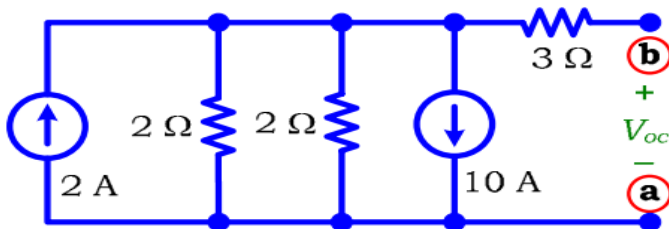

Combine the // resistors: $2//2 = 1\Omega$

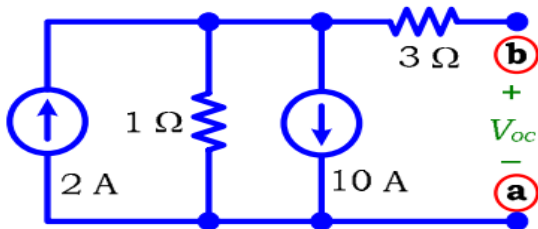

Combine the 2 sources we get $I=8A$ (down)

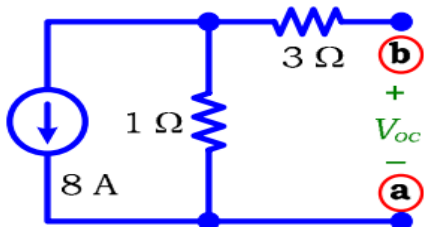

ST again gives : $V_{oc} = -8V$

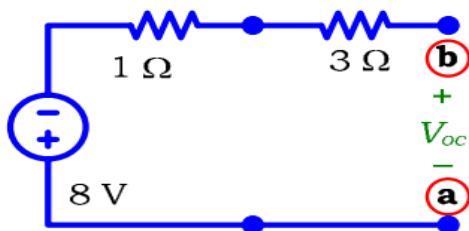

Draw circuit V in series with $3+1 = 4\Omega$

Lecture 10: Norton Equivalent Circuits and Maxm. Power

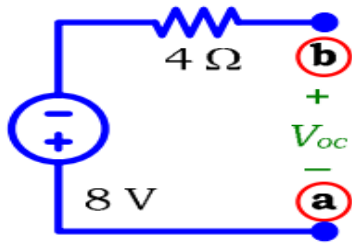

Find Rth

$$R_{TH} = \frac{v_x}{i_x} = 3\Omega + (2\Omega // 2\Omega) = 4\Omega$$

Therefore TEC : Draw circuit

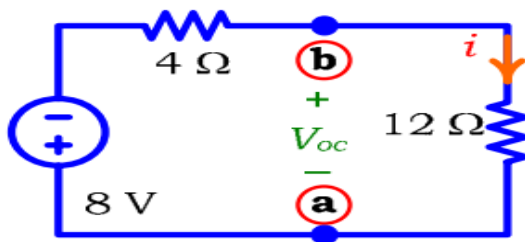

$$\therefore i = \frac{-8}{4+12} = 0.5A$$

To get NEC use ST:

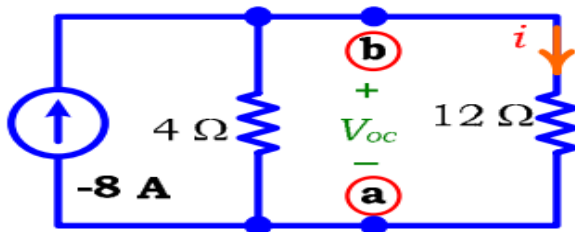
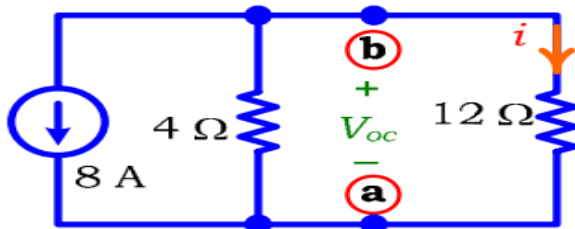

$$I_N = -8A \text{ (up)}$$

$$R_N = 4\Omega$$

Draw Circuit (add the 12-Ω resistor)

Lecture 10: Norton Equivalent Circuits and Maxm. Power

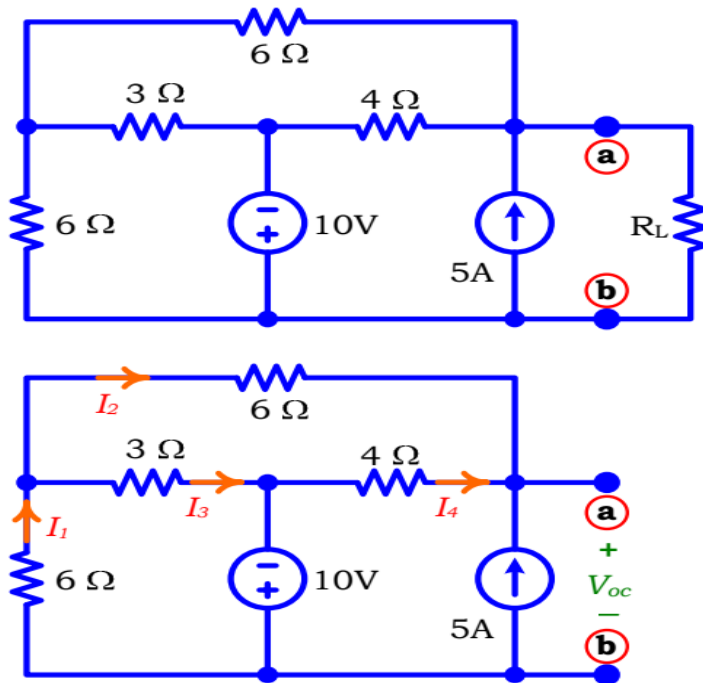

KVL (Highlight loop)

$$V_{oc} + 10 + 4I_4 = 0 \quad (1)$$

$$V_{oc} + 6I_1 + 6I_2 = 0 \quad (2)$$

$$\text{1 and 2 give: } 6I_1 + 6I_2 = 10 + 4I_4 \quad (3)$$

KCL at node a:

$$I_4 + I_2 + 5 = 0$$

$$\text{or } I_4 = -I_2 - 5 \quad (4)$$

Substitute (4) into (3) :

$$10 - 20 - 4I_2 = 6I_1 + 6I_2 \quad \Rightarrow \quad 10 + 10I_2 + 6I_1 = 0 \quad (5)$$

$$\text{KVL } -10 + 6I_1 + 3I_3 = 0 \quad (6)$$

KCL at node c

$$I_3 = I_1 - I_2 \quad (7)$$

$$\text{6 and 7 give: } -10 + 6I_1 + 3(I_1 - I_2) = 0$$

$$\text{or } 9I_1 - 3I_2 = 10 \quad (8)$$

Solve equations (5) and (8) [Subtract 3x(5) from 2x(6)] to get: $36I_2 = -50$ or

$$I_2 = -\frac{25}{18} \quad (9)$$

Lecture 10: Norton Equivalent Circuits and Maxm. Power

Substitute in (8) to get I_1 $9I_1 = 10 - 3\frac{25}{18}$

$$\therefore I_1 = \frac{35}{54} = 0.65A \quad (10)$$

Therefore $V_{oc} = -6(I_1 + I_2)$

$$\therefore V_{oc} = \frac{40}{9} = 4.44V$$