

8 – ma'ruza

Mavzu: Taqsimlangan rotasion mexanizmlari bo`lgan mashina agregati

Ma'ruza rejasi:

- 8.1. *Ikkita tarmoqli rotatsion mexanizmlari mashina agregatining umumlashgan sxemasi*
- 8.2. *Ikkita tarmoqli mashina agregatining harakati differensial tenglamasi*
- 8.3. *Texnologik mashinalarning ikkita tarmoqlangan rotatsion ishchi mexanizmlari*
- 8.4. *O'z- o'zini tekshirish savollari*

Adabiyotlar:

1. В.А. Зиновьев, А.П. Бессонов. Основы динамики машинных агрегатов. Машиностроение, Москва, 1964, с. 92-99
2. А. Джураев. Моделирование динамики машинных агрегатов хлопкоперерабатывающих машин. Фан, Ташкент, 1984, с. 55-67
3. А. Джураев. Динамика рабочих механизмов хлопкоперерабатывающих машин. Фан, Ташкент, 1987, с. 71-81

8.1. Ikkita tarmoqli rotatsion mexanizmlari mashina agregatining umumlashgan sxemasi

Paxta kompleksini texnologik mashinalarining ko'pchilik ishchi mexanizmlari rotatsion tarmoqlangan sistemalaridir. Ularning ishlashini spetsifik xususiyatiga paxta ta'sirini ularning bo'g'inlariga notekis yuklanishi kiradi. Shuning uchun bu mashina va mexanizmlarni ishlab chiqish va loyihalash, ularni real ishlash sharoitini hisobga olib, harakat dinamikasini o'rganish natijalariga asoslanishi kerak.

Ko'p massali ikkita tarmoqli sistemani umumiy ko'rinishda ko'ramiz (8.1 - rasm).

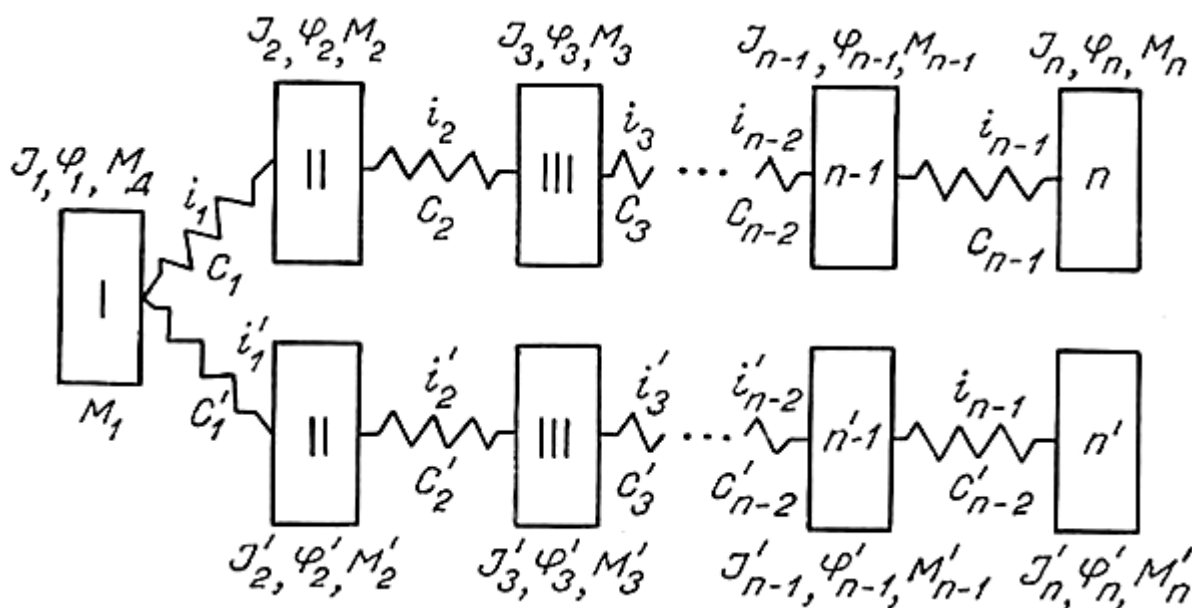

8.1 – rasm. Rotatsion mexanizmlili ko'p massali mashina agregatlarini hisoblash sxemasi

8.2. Ikkita tarmoqli mashina agregatining harakati differensial tenglamasi

Ko'p massali tarmoqlangan Sistema hisoblangan mashina agregatini harakatini tasvirlovchi differensial tenglamalar sistemasi quyodagi ko'rinishda bo'ladi:

$$\frac{1}{2\omega_c M_\kappa} \dot{M}_\delta + \frac{S_\kappa}{2M_\kappa} M_\delta = \frac{\omega_0 - \dot{\varphi}_\delta}{\omega_0};$$

$$I_1 \ddot{\varphi}_1 = M_\delta - b_1 \Delta \dot{\varphi}_1 - c_1 \Delta \varphi_1 - b'_1 \Delta \dot{\varphi}'_1 - c'_1 \Delta \varphi'_1;$$

$$I_2 \ddot{\varphi}_2 = \frac{b_1}{i_1^{-1}} \Delta \dot{\varphi}_1 + \frac{c_1}{i_1^{-1}} \Delta \varphi_1 - b_2 \Delta \dot{\varphi}_2 - c_2 \Delta \varphi_2 - M_2;$$

.....

.....

.....

$$I_n \ddot{\varphi}_n = \frac{b_{n-1}}{i_{n-1}^{-1}} \Delta \dot{\varphi}_{n-1} + \frac{c_{n-1}}{i_{n-1}^{-1}} \Delta \varphi_{n-1} - M_n;$$

$$I'_2 \ddot{\varphi}'_2 = \frac{b'_1}{(i'_1)^{-1}} \Delta \dot{\varphi}'_1 + \frac{c'_1}{(i'_1)^{-1}} \Delta \varphi'_1 - b'_2 \Delta \dot{\varphi}'_2 - c'_2 \Delta \varphi'_2 - M'_2;$$

.....

.....

.....

$$I'_n \ddot{\varphi}'_n = \frac{b'_{n-1}}{(i'_{n-1})^{-1}} \Delta \dot{\varphi}'_{n-1} + \frac{c'_{n-1}}{(i'_{n-1})^{-1}} \Delta \varphi'_{n-1} - M'_n$$

bu yerda, M_δ , M_K , φ_1 – yurituvchining momenti, uning kritik qiymati, yurituvchi rotorini buchakli siljishi;

S_K – yurituvchining sirpanishi;

I_1 – yurituvchi rotorini inersiya momenti;

$\varphi_1, \varphi_2, \dots, \varphi_n, \varphi_1', \varphi_2', \dots, \varphi_n'$ – sistemaning aylanuvchi massalarini burchak siljishlari;

I_2, I_3, \dots, I_n – birinchi tarmoq uchun *II, III, ..., n* aylanuvchi massalarni inersiya momentlari;

I_2', I_3', \dots, I_n' – birinchi tarmoq uchun *II', III', ..., n'* aylanuvchi massalarni inersiya momentlari;

$c_1, c_2, c_3, \dots, c_{n-1}$ – mashina agregati birinchi tarmog'i uchun qayishqoq uzatmalarning bikrlik koeffitsiyentlari;

$c_1', c_2', c_3', \dots, c_{n-1}'$ – mashina agregati ikkinchi tarmog'i uchun qayishqoq uzatmalarning bikrlik koeffitsiyentlari;

b_1, b_2, \dots, b_{n-1} va $b_1', b_2', \dots, b_{n-1}'$ – tegishlicha, mashina agregatining birinchi va ikkinchi tarmoqlari uchun qayishqoq uzatmalarning qovushqoq ishqalanish koeffitsiyentlari;

i_1, i_2, \dots, i_{n-1} va $i_1', i_2', \dots, i_{n-1}'$ – mashina agregatining birinchi va ikkinchi tarmoqlari uchun qayishqoq uzatmalarning uzatish sonlari;

M_2, M_3, \dots, M_n va M_2', M_3', \dots, M_n' – tarmoqlangan sistemaning aylanuvchi vallarini texnologik qarshilik momentlari.

Ko'p massali tarmoqlangan sistemalar uchun olingan differensial tenglamalar sistemasi texnologik mashinalarning ishchi mexanizmlariga taaluqli umumiy hisoblanadi.

8.3. Texnologik mashinalarning ikkita tarmoqlangan rotatsion ishchi mexanizmlari

Paxtani tozalash sanoatining mashinalarini ko'plab ishchi mexanizmlari ikkita tarmoqli rotatsion hisoblanadi: LO o'qli linterni arrali silindr mexanizmi (8.2, a -rasm), 3OVP tolani tozalovchi arrali baraban mexanizmi (8.2, b -rasm), KCM – 1.5 mashinasini ishchi organlarini yurituvchi mexanizmi (8.2, c -rasm), chigitlarni kalibrovkalovchi va saralovchi, DTP-80 arrali tola ajratuvchining ta'minlovchi mexanizmi (8.2, d -rasm), RX-1 paxta regeneratori tozalovchini arrali barabanlari mexanizmi (8.2, e -rasm), 6A12M1 shnekli tozalovchining ishchi organlari yuritmalari mexanizmi (8.2, f -rasm), OXB-10M paxtani tozalovchining ta'minlovchi mexanizmi va ajratuvchi barabani va boshqalar. Sanab o'tilgan rotatsion toifali ikki tarmoqli ishchi mexanizmlarni dinamik hisoblash sxemalari 8.2 – rasmda keltirilgan.

O'qli linterli arrali silindr mexanizmini 3OVM tozalovchining arrali baraban mexanizmini dinamik modellari bir xil, tegishlicha, harakat dinamikasini tavsiflovchi matematik modellari ham o'xshash. Ammo, mexanizmlarda bo'ladigan harakat xarakteri va dinamik jarayonlar turlicha. Shu sababli, ko'rsatilgan mexanizmlarning dinamik tadqiqoti natijalari ham har xil. Ko'rilayotgan mexanizmlarning matematik modelini keltiramiz:

$$\begin{aligned}M_{\delta} &= f(\dot{\varphi}_1); I_1 \ddot{\varphi}_1 = M_{\delta} - b_1 \Delta \dot{\varphi}_1 - c_1 \Delta \varphi_1 - b_2 \Delta \dot{\varphi}_2 - c_2 \Delta \varphi_2; \\I_2 \ddot{\varphi}_2 &= (b_1 \Delta \dot{\varphi}_1 + c_1 \Delta \varphi_1) i_1 - (M_1 \pm \delta M_1); \\I_3 \ddot{\varphi}_3 &= (b_2 \Delta \dot{\varphi}_2 + c_2 \Delta \varphi_2) i_2 - (M_2 \pm \delta M_2); \\ \Delta \varphi_1 &= (\varphi_1 - i_1 \varphi_2); \Delta \varphi_2 = (\varphi_1 - i_2 \varphi_3)\end{aligned}$$

Shunga o'xshash, paxtani qayta ishlovchi mashinalarning ikki tarmoqli rotatsion ishchi mexanizmlarini mashina agregatlarini differensial tenglamalar sistemasini keltirish mumkin. Valikli tolani ajratuvchini ikki tarmoqli beshta masslai sistemasini ko'ramiz.

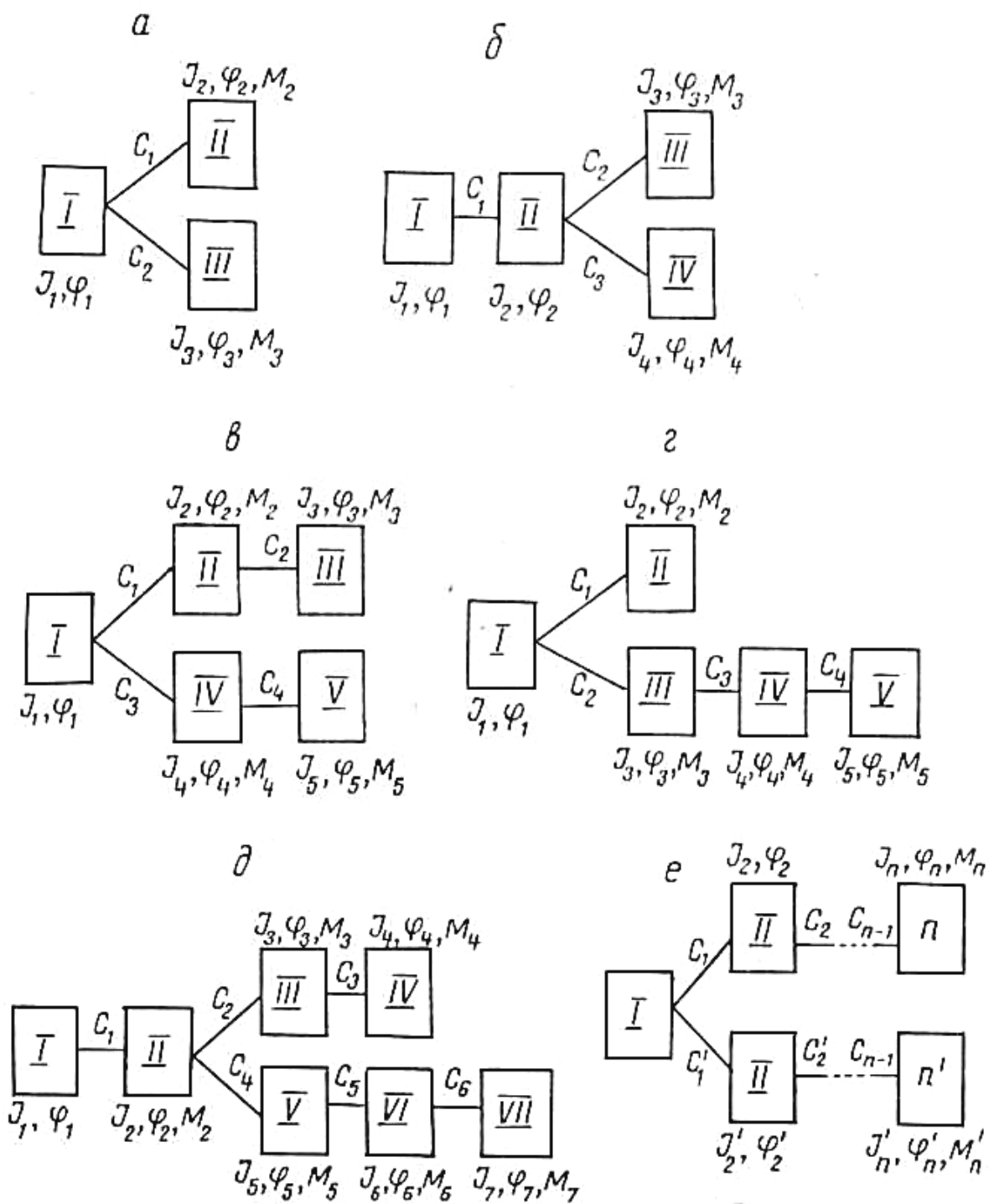

8.2 – rasm.

Mashina agregatining harakati quyidagi differensial tenglamalar sistemasi bilan ta'riflanadi:

$$\begin{aligned} \dot{M}_\delta &= 2\omega_c M_\kappa - 2M_\kappa \frac{\omega_c}{\omega_0} \dot{\varphi}_\delta - \omega_c S_\kappa M_\delta; \\ I_\delta \ddot{\varphi}_\delta &= M_\delta - c_1(\varphi_\delta - i_1\varphi_1) - b_1(\dot{\varphi}_\delta - i_1\dot{\varphi}_1) - c_2(\varphi_\delta - i_2\varphi_2) - b_2(\dot{\varphi}_\delta - i_2\dot{\varphi}_2); \\ I_1 \ddot{\varphi}_1 &= i_1 c_1(\varphi_\delta - i_1\varphi_1) + i_1 b_1(\dot{\varphi}_\delta - i_1\dot{\varphi}_1) - M_1; \\ I_2 \ddot{\varphi}_2 &= i_2 c_2(\varphi_\delta - i_2\varphi_2) + i_2 b_2(\dot{\varphi}_\delta - i_2\dot{\varphi}_2) - c_3(\varphi_2 - i_3\varphi_3) - b_3(\dot{\varphi}_2 - i_3\dot{\varphi}_3) - M_2; \\ I_3 \ddot{\varphi}_3 &= i_3 c_3(\varphi_2 - i_3\varphi_3) + i_3 b_3(\dot{\varphi}_2 - i_3\dot{\varphi}_3) - c_4(\varphi_3 - i_4\varphi_4) - b_4(\dot{\varphi}_3 - i_4\dot{\varphi}_4) - M_3; \\ I_4 \ddot{\varphi}_4 &= i_4 c_4(\varphi_3 - i_4\varphi_4) + i_4 b_4(\dot{\varphi}_3 - i_4\dot{\varphi}_4) - M_4; \end{aligned}$$

bu yerda, $I_\delta, I_1, I_2, I_3, I_4$ – yurituvchi rotorining va aylanuvchi massalarning inersiya momentlari;

$\varphi_\delta, \varphi_1, \varphi_2, \varphi_3, \varphi_4$ – aylanuvchi massalarning burchak siljishlari;

$M_\delta, M_1, M_2, M_3, M_4$, – yurituvchining harakatlantiruvchi momenti va vallardagi paxtani qarshilik momentlari.

Olingan differensial tenglamalar sistemasi chiziqsiz bo'lganligi uchun ularni analitik yechimi imkoniyati yo'q. Shuning uchun uning yechimini EHM da amalga oshirish maqsadga muvofiq.

8.4. O'z- o'zini tekshirish savollari

1. Tarmoqlangan mashina agregatlarini dinamik modeli qanday tuziladi?
2. Tarmoqlangan sistemalarni qayishqoq uzatmalari momentlari qanday aniqlanadi?
3. Tarmoqlagan sistemalarning matematik modellari qanday tuziladi?