

COURSE OBJECTIVE

To study the construction material used in civil engineering with the properties.

UNIT 1 BUILDING MATERIALS

Soil - classification of soil - Stone, Criteria for selection - Tests on stones - Deterioration and Preservation of stone work - Bricks - Classification - Manufacturing of clay bricks - Tests on bricks - Compressive Strength - Water Absorption - Efflorescence - Bricks for special use - Refractory bricks - Cement bricks, Fly Ash Bricks and Concrete hollow blocks - Light weight concrete blocks.

SOIL

Soil is an individual natural body which consists of a wide variety of minerals, organic matter, gases, and liquid that occurs on the top layer of the earth which is responsible to support the rooted plants in a natural environment. To an engineer, soil is the natural aggregate of mineral grains, with or without of organic constituents that can be separated by gentle mechanical means such as agitation in water. It covers huge portion of the earth's crust. It will be called as 'Skin of the Earth' or 'Cover of the Earth'.

Soils are formed from the disintegration of rocks by various weathering processes. In general, rocks extend upto a depth of 20km in the earth's surface. The major rock types are igneous, sedimentary, and metamorphic. All soils originate, directly or indirectly from various rock types. According to Terzaghi, soils can be broken down into their constituent particles relatively easily, such as by agitation in water.

SOIL CLASSIFICATION

Soil classification is a dynamic subject, from the structure of the system itself. Soil classification can be approached from the perspective of soil as a material and soil as a resource

Soil shall be broadly divided into 3 divisions

Coarse-Grained Soils

In these soils, more than half the total material by weight is larger than 75-micron IS Sieve size.

Fine-Grained Soils

In these soil, more than half of the material by weight is smaller than 75-micron

Highly organic soil and other miscellaneous soil materials

These soils contain large percentages of fibrous organic matter such as peat and particles of decomposed vegetation. In addition, certain soils containing shells, concretions, cinders and other non-soil materials in sufficient quantities are also grouped in this division.

The coarse-grained soils shall be divided into two subdivisions, namely:

Gravels - In these soils, more than half the coarse fraction (+75 micron) is larger than 4.75-mm IS Sieve size. This subdivision includes gravels and gravelly soils.

Sand - In these soils, more than half the coarse fraction (+75 micron) is smaller than 4.75-mm. This subdivision includes sand and sandy soils.

Fine-Grained Soils shall be further divided into 3 subdivisions on the basis of the following arbitrarily selected values of liquid limit:

- Silts and clays of low compressibility - having a liquid limit less than 35 (represented by symbol L),
- Silts and clays of medium compressibility - having a liquid limit greater than 35 and less than 50 (represented by symbol I) and
- Silts and clays of high compressibility - having a liquid limit greater than 50 (represented by symbol H).

Soil classification is a medium of communication among soil engineers for geotechnical practices. This differentiates the coarse grained and fine grained soils. This also provides the basis for detailed geotechnical investigations. As per I.S.1498-1970, the soil is classified as below according to their sizes.

If the soil is coarse grained, it is further identified by estimating and recording the percentage of

- a) Gravel sized particle, size range from 80 mm to 4-75..mm IS Sieve size (or approximately 5 mm size)
- b) Sand size particles, size range from 4-75 to 75-micron IS Sieve size and
- c) Silt and clay size particles, size range smaller than 75-micron IS Sieve.

Classification Based on Grain Size

The range of particle sizes encountered in soils is very large: from boulders with dimension of over 300 mm down to clay particles that are less than 0.002 mm. Some clays contain particles less than 0.001 mm in size which behave as colloids, i.e. do not settle in water.

In the **Indian Standard Soil Classification System (ISSCS)**, soils are classified into groups according to size, and the groups are further divided into coarse, medium and fine sub-groups.

The grain-size range is used as the basis for grouping soil particles into boulder, cobble, gravel, sand, silt or clay.

Very coarse soils	Boulder size		> 300 mm
	Cobble size		80 - 300 mm
Coarse soils	Gravel size (G)	Coarse	20 - 80 mm
		Fine	4.75 - 20 mm
	Sand size (S)	Coarse	2 - 4.75 mm
		Medium	0.425 - 2 mm
		Fine	0.075 - 0.425 mm
	Fine soils	Silt size (M)	
Clay size (C)			< 0.002 mm

Boulder	above 300mm
Cobble	300-75mm
Coarse Gravel	75-20mm
Fine Gravel	20-4.75mm
Coarse Sand	4.75-2mm
Medium Sand	2.0 -0.425mm
Fine Sand	0.425—0.075mm
Silt	0.075-0.002mm
Clay	below 0.002mm

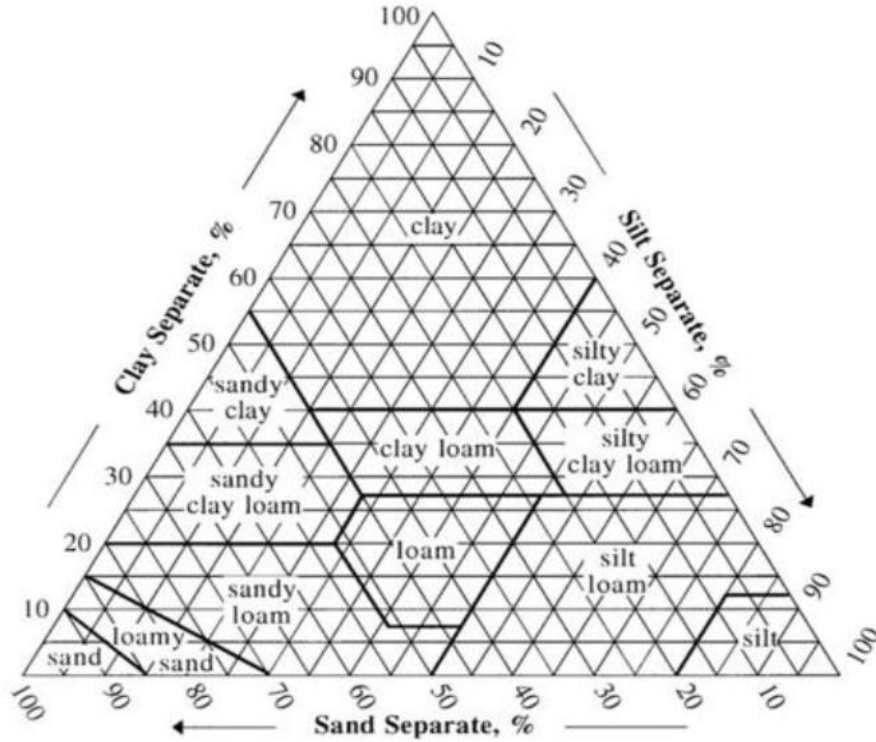

COMPARISON OF PARTICLE SIZE SCALES

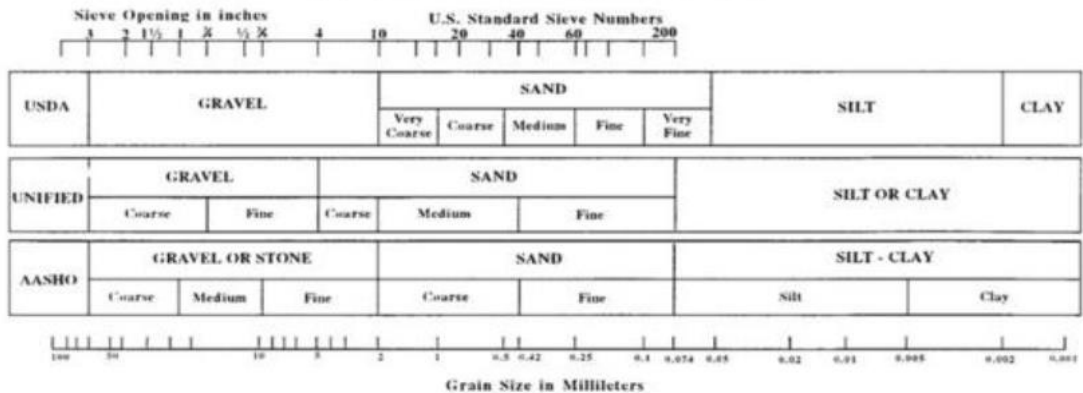

STONES

Stones are obtained from the different types of rocks occurring in nature. The properties of a rock are governed by the properties of minerals present in its structure. The common minerals found in igneous rocks are Augite, Chlorite, Felspar, Hornblende, Mica, Olivine, Plagioclase, Quartz, Serpentine. The minerals found in sedimentary rocks are, Calcite, Magnesite, Dolomite, Glauconite, Limonite, Gypsum, Anhydrate. It is estimated that three-fourth of the land area of the globe is underlain by sedimentary rocks and the remaining one-fourth by igneous and metamorphic rocks. The texture or structure of a rock has different types such as, Compact Crystalline, Conglomerate, Foliated, Glassy, Granular crystalline, Pisolitic, Porous granular, porphyritic, vesicular.

Stones are used for floors, roofs, foundations, walls, columns, lintels, arches etc. Stones are used for Paving, face-work , as ballast for railways, blocks in the construction of bridges, dams, piers, retaining walls , flux in blast furnaces .

SELECTION OF STONES

- 4 main performance criteria
- Stain resistance
- Strength
- Resistance to abrasion
- Durability

Stones should be selected according to their use. In any case, it should be durable and free from defect.

Stone for pavement

Generally, hard stones of any type can be used for paving walkways and driveway

stone for flooring

With the help of machines large size slabs for flooring even from hard rock like Granite can also be produced.

Stone for facing work in building

The facing stones should have attractive colours and durable. The imperious varieties are preferred as they do not get change in colour with time, especially in an industrial atmosphere.

Stones for concrete

Hard igneous rock—preferred for high strength concrete

Source: Building Material World

The conditions which govern the selection of stone for structural purposes are cost, fashion, ornamental value and durability, although the latter property is frequently overlooked or disregarded. Cost is largely influenced by transportation charges, difficulties in quarrying and cutting, the ornamental features, and the durability of stone. The type of dressing of stone may make a difference to the cost, particularly with the stones derived from igneous rocks.

When the cost of quarried stone to cost of finished stone is considered, it will be found that the labour cost is far greater than the price of the stone. Thus, a difference in the price between two alternative stones is unimportant and it would be unwise to reject a more durable stone on the grounds that it was costly.

Another factor which should be considered is the suitability of the stone for the type of design, for example, for a highly carved designs if, by mistake, a harder stone such as granite is selected the cost will be affected. Colour, arrangement and shape of mineral constituents greatly influence fashion and ornamental value. One of the first factors influencing the selection of stone for a particular work will be colour.

It is important that the designer is aware about how the colour is likely to change after long exposure and in particular how it may vary in polluted atmospheres. As an example limestone, being slightly soluble in water, will remain clean in portions facing rain but retain a film of soot in sheltered areas. This results in strong colour contrast.

Resistance to fire and weathering—factors which are largely influenced by the mineral constitution of the rock—are the most important determinators of durability. It is very important to select a stone according to its exposure conditions. Limestones when used in

areas not exposed to rain but acted upon by sulphur gases of polluted atmosphere, form a hard and impermeable surface skin which subsequently blisters and flakes off. It must be noted that flaking of this kind occurs mainly on external work only, although the air inside the building is almost equally polluted, probably due to the damper conditions inside.

Limestones, sandstones and granites all tend to crack and spall when exposed to fire, and there is really little to choose between them in this respect.

TESTS FOR STONES

The building stones are to be tested for their different properties. Following are such tests for the stones:

- 1) Acid Test
- 2) Attrition Test
- 3) Crushing test
- 4) Crystallization test
- 5) Freezing and thawing test
- 6) Hardness test
- 7) Impact test
- 8) Microscopic test
- 9) Smith's test
- 10) Water absorption test

1. Acid Test:

In this test, a sample of stone weighing about 0.0 to 1N is taken. It is placed in a solution of hydrochloric acid having strength of one percent and it is kept there for seven days. The solution is agitated at intervals. A good building stone maintains its sharp edges and keeps its surface free from powder at the end of this period. If edges are broken and powder is formed on the surface, it indicates the presence of calcium carbonate and such as stone will have poor weathering quality. It is natural that this test cannot be applied to the limestones. This test is usually carried out on the sand stones.

2. Attrition Test:

This test is done to find out the rate of wear of stones which are used in road construction. The results of test indicate the resisting power of stones against the grinding action under traffic. Following procedure is adopted.

- i) The sample of stone is broken into pieces of about 60mm size.
- ii) Such pieces, weighing 50N, are put in both the cylinders of Devals attrition test machine. The diameter and length of cylinder are respectively 200mm and 340mm.



- iii) The cylinders are closed. Their axes make an angle of 30° with the horizontal.
- iv) The cylinders are rotated about horizontal axis for 5 hours at the rate of 30 R.P.M.
- v) After this period, the contents are taken out from the cylinders and they are passed through a sieve of 1.50mm mesh.
- vi) The quantity of material which is retained on the sieve is weighed.
- vii) The percentage wear is worked out as follows:

$$\text{Percent wear} = (\text{loss in weight}/\text{initial weight}) \times 100$$

3. Crushing Test:

The compressive strength of stone is found out with the help of this test.

The sample of stones is cut into cubes of size 40mm x40mmx40mm. The sides of cubes are finely dressed and finished. The minimum number of specimens to be tested is three. Such specimens should be placed in water for about 72 hours prior to test and thereafter tested in saturated condition.

The load-bearing surface is then covered with plaster of paris or 5 mm thick plywood. The load is applied axially on the cube in a crushing test machine. The rate of loading is 13.72M/mm² per minute. The crushing strength of the stone per unit area is the maximum load at which its sample crushes or fails divided by the area of the bearing face of the specimen.



4. Crystallisation tests:

In this test, at least four cubes of stone with side as 40 mm are taken. They are dried for 72 hours and weighted. They are then immersed in 14 percent solution of Na₂SO₄ for 2 hours. They are dried at 100°C and weighted. The difference in weight is noted. This procedure of drying, weighing, immersing and reweighing is repeated at least five times. Each time, the change in weight is noted and it is expressed as a percentage of original weight.

It is to be noted that the crystallisation of CaSO_4 in pores of stone causes the decay of stone due to weathering. But, as CaSO_4 has low solubility in water, it is not adopted in this test.

5. Freezing and thawing test:

The specimen of stone is kept immersed in water for 2 hours. It is then placed in a freezing mixture at -12°C for 24 hours. It is then thawed or warmed at atmospheric temperature. This should be done in shade to prevent any effect due to wind, sun rays, rain etc. Such a procedure is repeated several times and behaviour of stone is carefully observed.

6. Hardness test:

To determine the hardness of a stone, the test is carried out as follows:

- i) A cylinder of diameter 25 mm and height 25 mm is taken out from the sample of stone.
- ii) It is weighed
- iii) It is placed in Dorry's testing machine and pressed with a pressure of 12.50N
- iv) The annular steel disc of machine is then rotated at a speed of 28 R.P.M
- v) During the rotation of disc, the coarse sand of standard specification is sprinkled on the disc.
- vi) After 1000 revolutions, the specimen is taken out and weighted.
- vii) The coefficient of hardness is found out from the following equation:
- viii) Coefficient of hardness = $20 - [(\text{loss in weight in gm})/3]$



7. Impact test:

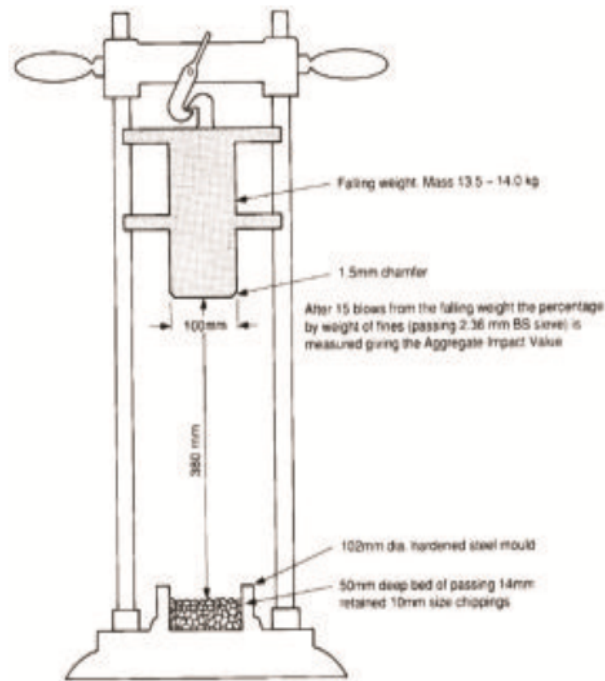

Figure 1. Apparatus for the aggregate impact test (Millard, 1993)

To determine toughness of a stone, the impact test is carried out in page impact machine as follows:

- i) A cylinder of diameter 25 mm and height 25mm is taken out from the sample of stone.
- ii) It is placed on cast-iron anvil of machine
- iii) A steel hammer of weight 20 N is allowed to fall axially in a vertical direction over the specimen
- iv) The height of first blow is 1 cm, that of second blow is 2 cm, that of third blow is 3 cm, and so on.
- v) The blow at which specimen breaks is noted. If it is n th blow, n represents the toughness index of stone.

8. Microscopic test:

In this test, the sample of stone is subjected to the microscopic examination. The thin sections of stone are taken and placed under the microscopic to study various properties such as:

- i) Average grain size.
- ii) Existence of pores, fissures, veins and shakes
- iii) Mineral constituents
- iv) Nature of cementing material
- v) Presence of any harmful substance
- vi) Texture of stone etc.

9. Smiths test:

This test is performed to find out the presence of soluble matter in a sample of stone. The few chips or pieces of stones are taken and they are placed in a glass tube. This tube is then filled with clear water. After about an hour, the tube is vigorously stirred or shaken. The presence of earthy matter will convert the clear water into dirty water. If water remains clear, the stone will be durable and free from any soluble matter. On the other hand, if the water becomes dirty and free from any soluble matter. On the other hand, if the water becomes dirty, it will indicate that the stone contains too much of soluble earthy and mineral matters.

10. Water absorption test:

Following procedure is adopted for this test:

- i) From the given sample of stone, a cube weighing about 0.50 N is prepared. Its actual weight is recorded. Let it be W_1 N.
- ii) The cube is then immersed in distilled water for a period of 24 hours.
- iii) The cube is taken out of water and surface water is wiped off with a damp cloth.
- iv) It is weighted again. Let its weight be W_2 N.
- v) The cube is suspended freely in water and its weight is recorded. Let it be W_3 N.
- vi) The water is boiled and cube is kept in boiling water for five hours.
- vii) It is then removed and surface water is wiped off with a damp cloth. Its weight is recorded. Let it be W_4 N. From the above data, the values of the following properties of stone are obtained :

$$\text{Percentage absorption by weight after 24 hours} = [(W_2 - W_1) / W_1] \times 100$$

$$\text{Percentage absorption by volume after 24 hours} = [(W_2 - W_1) / (W_2 - W_3)] \times 100$$

[Volume of displaced water = $W_2 - W_3$]

$$\text{Percentage porosity by volume} = [(W_4 - W_1) / (W_2 - W_3)] \times 100$$

$$\text{Density} = [W_1 / (W_2 - W_3)] \text{ N/m}^3$$

$$\text{Specific Gravity} = W_1 / (W_2 - W_3)$$

$$\begin{aligned} \text{Saturation Coefficient} &= (\text{Water Absorption} / \text{Total Porosity}) \\ &= (W_2 - W_1) / (W_4 - W_1) \end{aligned}$$