

Microphone Directional Characteristics

Microphones: Polar pattern /Microphone Directionality

Graphical representation of microphone pick-up pattern or (Polar pattern)

The pickup, or polar pattern, of a microphone is the shape of the area around it where it picks up sounds with maximum fidelity and volume. Nearly all microphones can pick up sounds from areas outside the ideal pattern, but their quality is not as good. For best results, the sound source should be within the pickup pattern, generating enough volume to allow the audio switcher to keep the volume control pot at a minimal level.

Microphones are classified according to the following three basic polar patterns.

There are three common type of polar pattern

1. Uni-Directional
2. Bi- Directional
3. Omni- Directional

Uni- Directional

Cardioid microphone

The unidirectional microphone picks up sound from only one direction. Because of this characteristic, the unidirectional microphone is used most frequently for television work. It is used by aiming it in the direction of the sound source being recorded. One advantage to the unidirectional microphone is its ability to reject unwanted sounds at the side and rear of the direction the microphone is aimed.

Front side (pick up)

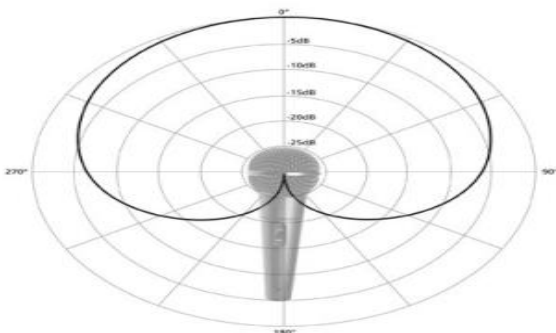

Bi-directional

As the name implies, the bidirectional microphone picks up sound in two directions. This type of microphone is used primarily in the broadcast or recording studio. It is also used for critical sound reinforcement applications in which **front and rear**

Figure of Eight (8)

Front side (pick up)

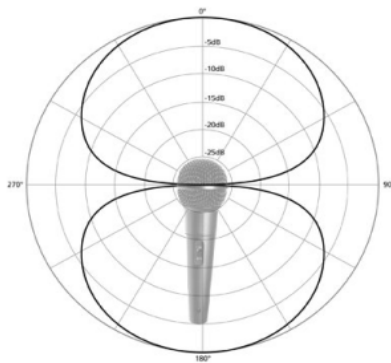

Rear side (pick up)

Omni-directional

The Omni-directional (or all directional) microphone is live in all directions. This type of microphone has sensitivity characteristics in which sound is picked up in a 360-degree radius. The use of this microphone in television production is limited; however, in certain situations, you may use it to create a specific sound presence. One example is recording crowd noise for a sports production.

360 degree (pick up)

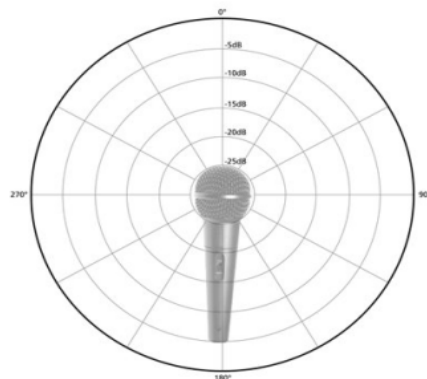

PHANTOM POWER SUPPLY

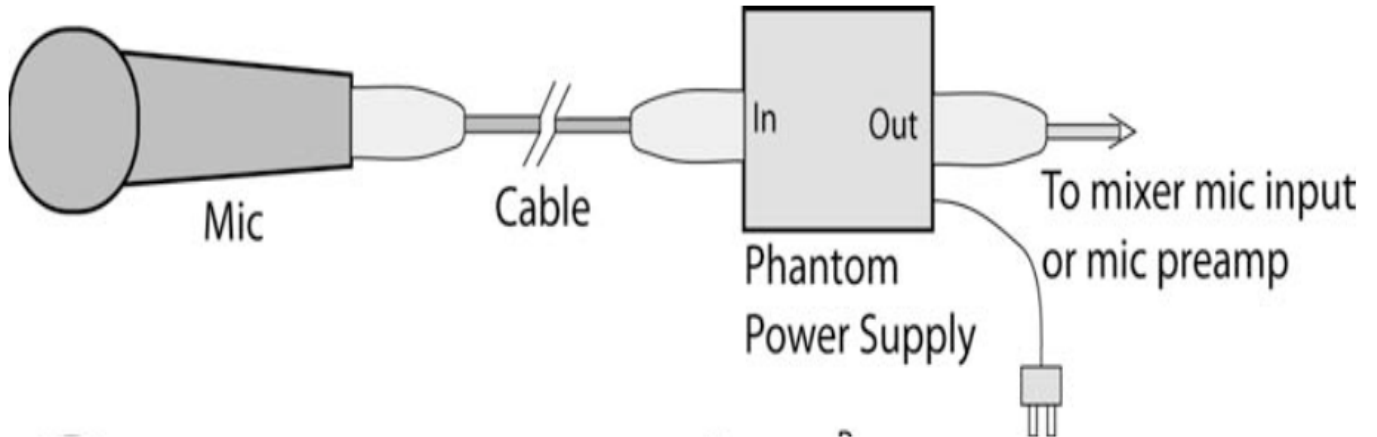

Condenser microphones need phantom power to operate their internal circuitry. Phantom power is a DC voltage—typically 48 volts—that is applied to both signaling lines of a balanced connector. In practical terms, 48 volts are applied to both pin 2 and pin 3 of an XLR. As both pins are getting the same voltage, in the same polarity, it's cancelled out at the input transformer.

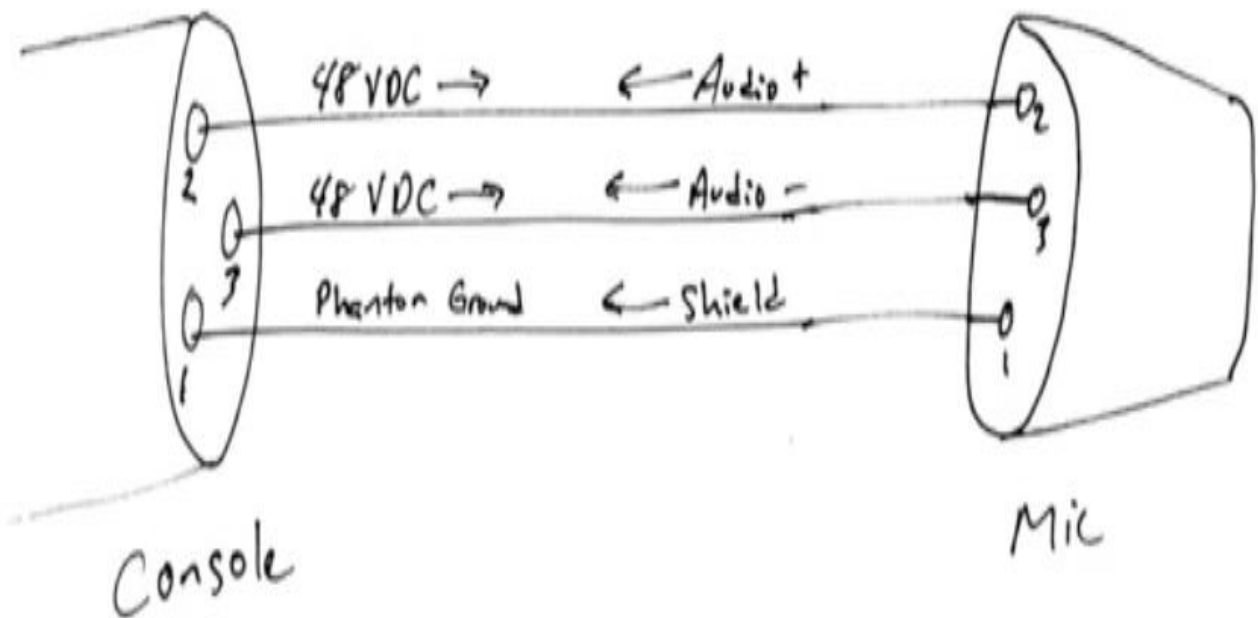

Audio signals are generated based on the differences between the “high” or “hot” (pin 2) and the “low” or “cold” (pin 3) signals; thus if the same voltage (48) is appearing on them at the same time, it is effectively 0 volts.

That is to say, there is no delta or difference between them, so to the input amplifier in the mixer, there is no signal.

Since phantom power is direct current, it can coexist on the audio lines with no problem. A condenser mic is free to pull power from either pin 2 or pin 3, and the current returns to ground over the shield

How is Phantom Power Generated?

Phantom power can be generated from sound equipment such as mixing consoles and preamplifiers. Special phantom power supplies are also available.