

FUNDAMENTALS OF ELECTRONICS

WEEK 7_LECTURE 7: DESCRIPTION AND APPLICATIONS OF ACTIVE DEVICES/ PART 2: TRANSISTORS

4/22/2022

Lecturer: NSABIMANA Camille, B.Sc. Eng., M.Sc. IT

Content

2

- ❑ **Description of different types of transistor:**
 - BJT (NPN and PNP)
 - FET (JFET and MOSFET)
 - UJT
 - IGBT

- ❑ **Selection of transistor based On:**
 - Specifications & ratings
 - Applications

Definition of Active Devices

3

An **active device** is any type of circuit component with the **ability to electrically control electric charge flow** (electricity controlling electricity). In order for a circuit to be properly called electronic, it must contain at least one **active device**.

Identification of different types of transistor

BJT

4

- A Bipolar Junction Transistor (also known as a BJT or BJT Transistor) is a three-terminal semiconductor device consisting of two p-n junctions which are able to amplify or magnify a signal. It is a **current** controlled device. The three terminals of the BJT are the base, the collector and the emitter. A BJT is a type of **transistor** that uses both electrons and holes as charge carriers.
- A signal of small amplitude if applied to the base is available in the amplified form at the collector of the transistor. This is the amplification provided by the BJT. Note that it does require an external source of **DC** power supply to carry out the amplification process.
- There are two types of bipolar junction transistors – **NPN transistors** and **PNP transistors**. A diagram of these two types of bipolar junction transistors is given below.

06/08/2022

BJT Bi-polar Junction Transistor symbols

5

Difference Between NPN & PNP Transistor

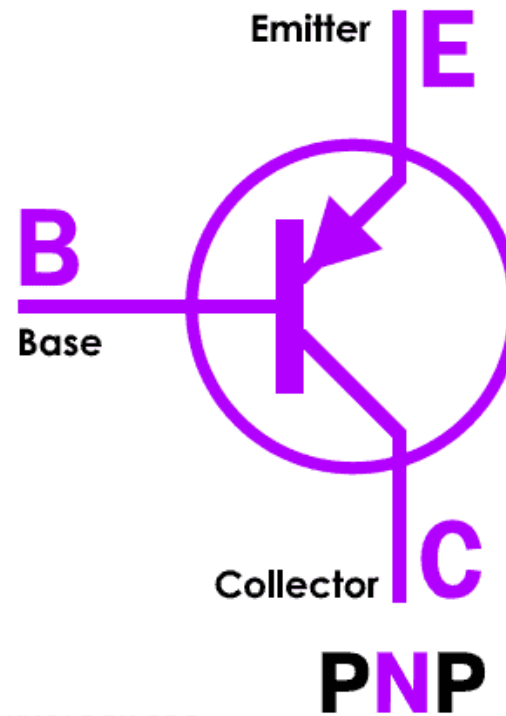
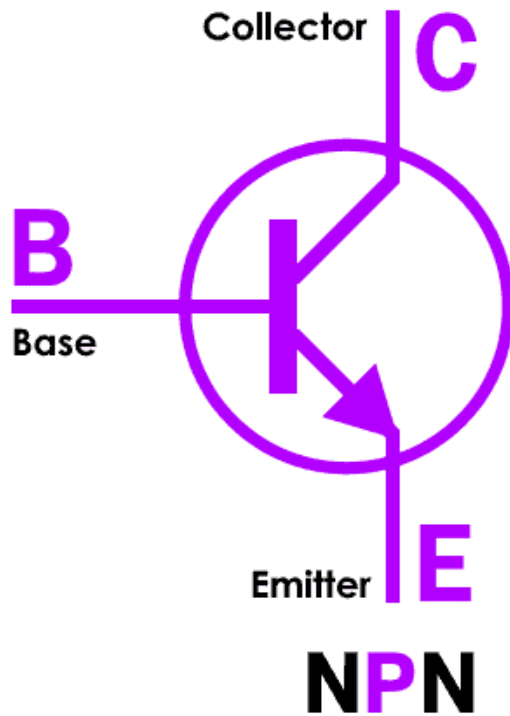

WWW.ELECTRICALTECHNOLOGY.ORG

BJT Cont'

From the above figure, we can see that every BJT has three parts named emitter, base and collector. J_E and J_C represent the junction of emitter and junction of collector respectively. Now initially it is sufficient for us to know that emitter based junction is forward biased and collector-base junctions are reverse biased. The next topic will describe the two types of these transistors.

The **modes of operation** for this **type of transistors**. The modes are:

- A: Common Base (CB) mode
- B: Common Emitter (CE) mode
- C: Common Collector (CC) mode

All three types of modes are shown below:

BJT Cont'

7

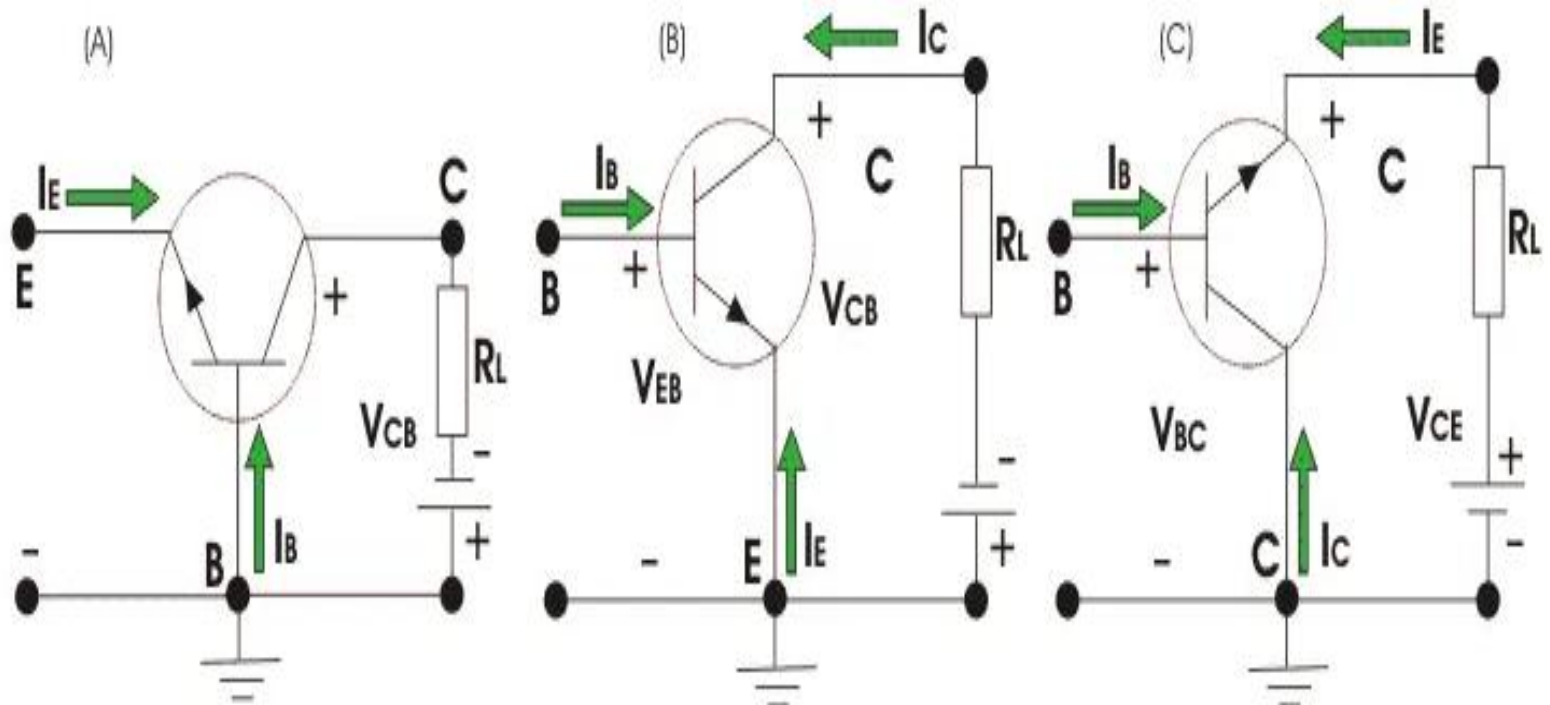

Source: <https://www.physics-and-radio-electronics.com/electronic-devices-and-circuits/transistors/bipolarjunctiontransistor/bjtoperationmodes.html>

06/08/2022

BJT Cont'

The transistor can be operated in three modes:

- Cut-off mode
- Saturation mode
- Active mode

In order to operate transistor in one of these regions, we have to supply dc voltage to the npn or pnp transistor. Based on the polarity of the applied dc voltage, the transistor operates in any one of these regions.

- Applying dc voltage to the transistor is nothing but the biasing of transistor.

Cutoff mode

9

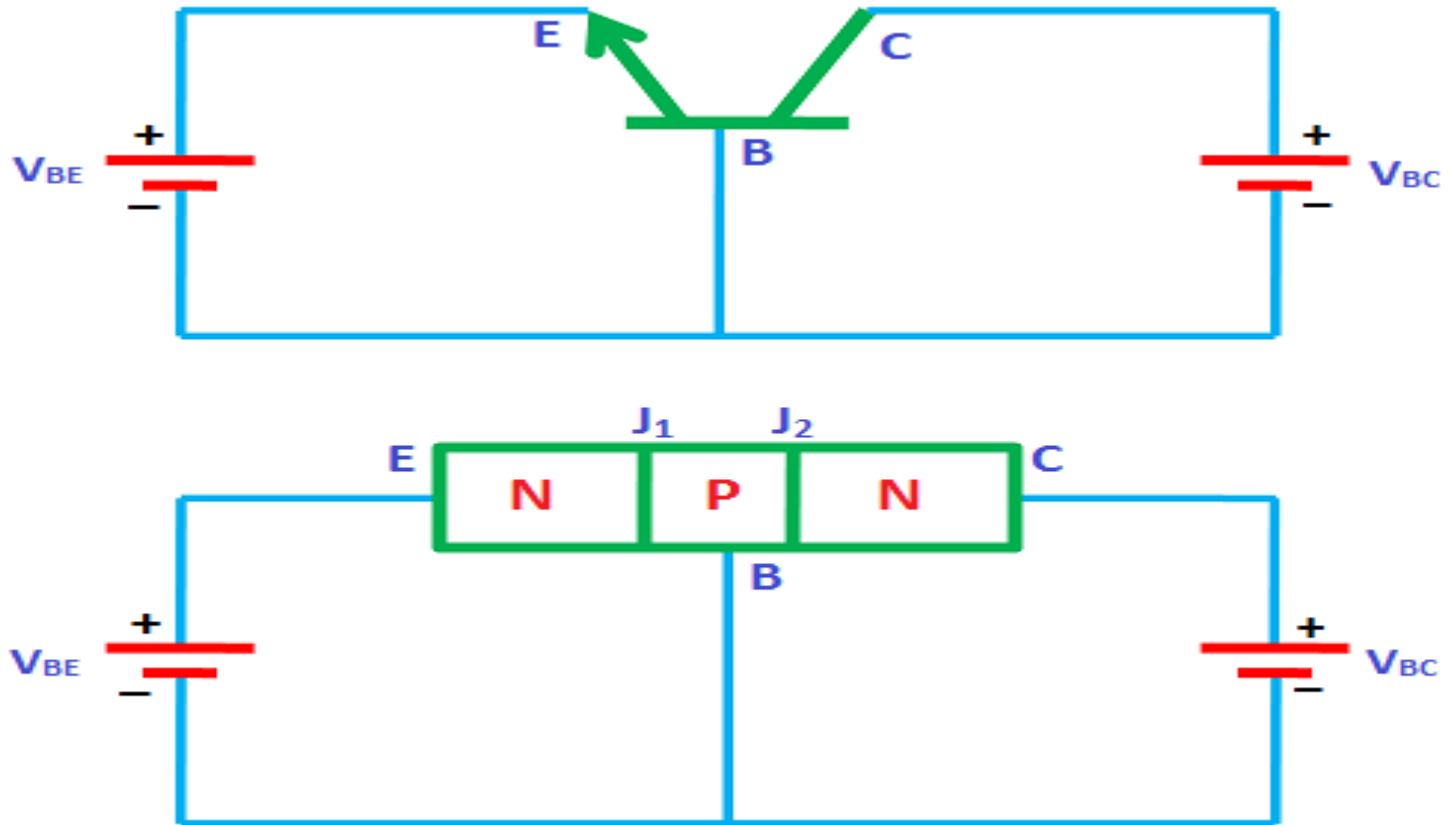

Source: <https://www.physics-and-radio-electronics.com/electronic-devices-and-circuits/transistors/bipolarjunctiontransistor/bjtoperationmodes.html>

Cutoff mode cont'

- In the cutoff mode, both the junctions of the transistor (emitter to base and collector to base) are **reverse biased**. In other words, if we assume two **p-n junctions** as two **p-n junction diodes**, both the diodes are reverse biased in cutoff mode. We know that in reverse bias condition, no **current** flows through the device. Hence, no current flows through the transistor. Therefore, the transistor is in off state and acts like an open switch.
- The cutoff mode of the transistor is used in switching operation for switch OFF application.

Saturation mode

11

- In the saturation mode, both the junctions of the transistor (emitter to base and collector to base) are **forward biased**. In other words, if we assume two p-n junctions as two p-n junction diodes, both the diodes are forward biased in saturation mode. We know that in forward bias condition, current flows through the device. Hence, electric current flows through the transistor.

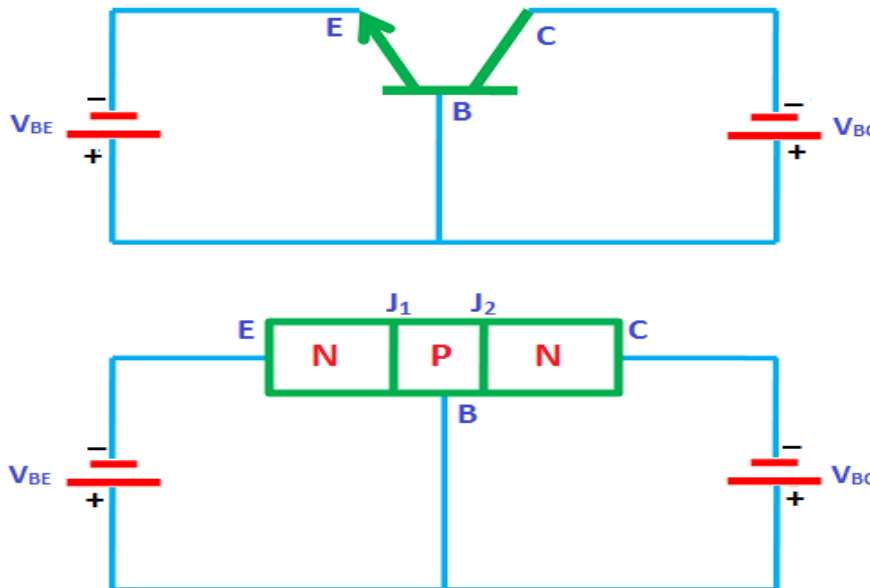

Source: <https://www.physics-and-radio-electronics.com/electronic-devices-and-circuits/transistors/bipolarjunctiontransistor/bjtooperationmodes.html>

Saturation mode cont'

- In saturation mode, **free electrons** (charge carriers) flows from emitter to base as well as from collector to base. As a result, a huge current will flow to the base of transistor.
- Therefore, the transistor in saturation mode will be in on state and acts like a closed switch.
- The saturation mode of the transistor is used in switching operation for switch ON application.
- From the above discussion, we can say that by operating the transistor in saturation and cutoff region, we can use the transistor as an ON/OFF switch.

Active mode

13

- In the active mode, one junction (emitter to base) is forward biased and another junction (collector to base) is reverse biased. In other words, if we assume two p-n junctions as two p-n junction diodes, one diode will be forward biased and another diode will be reverse biased.

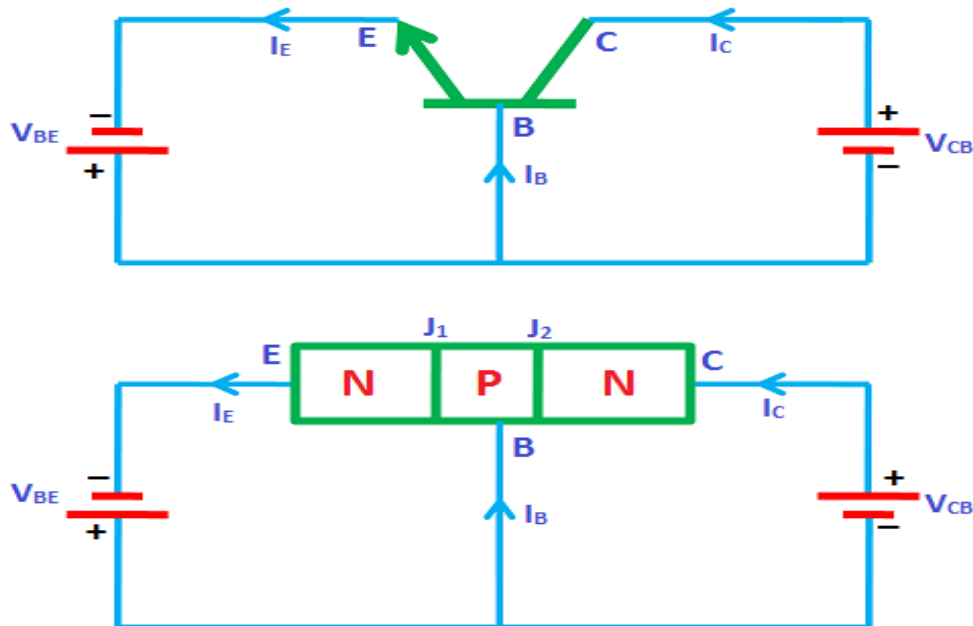

Source: <https://www.physics-and-radio-electronics.com/electronic-devices-and-circuits/transistors/bipolarjunctiontransistor/bjtoperationmodes.html>

Active mode cont'

- The active mode of operation is used for the amplification of current.
- From the above discussion, we can say that the transistor works as an ON/OFF switch in saturation and cutoff modes whereas it works as an amplifier of current in active mode.

FET

A Field Effect Transistor (FET) is a three terminal device namely the source, drain and gate. It is made of one basic p-n junction. It is also called a Junction Field Effect Transistor (JFET).

FET has the following terminal:

- **Source:** It is the terminal through which the majority carriers **enter** the channel, is called the *source* terminal S and the conventional current entering the channel at S is designated as I_S .
- **Drain :** It is the terminal through which the majority carriers leave the channel, is called the *drain* terminal D and the conventional current leaving the channel at D is designated as I_D . The drain-to-source voltage is called V_{DS} , drives the drain current I_D .

FET (cont')

- **Gate:** There are two internally connected heavily doped impurity regions formed by alloying, by diffusion, or by any other method available to create two P-N junctions. These impurity regions are called the gate G. A voltage V_{GS} is applied between the gate and source in the direction to reverse-bias the P-N junction. Conventional current entering the channel at G is designated as I_G .
- **Channel:** It is the space between the source and drain, sandwiched between the two gates is called the *channel* and the majority carriers move from source to drain through this channel.
- The field effect transistor (*FET*) has, by virtue of its construction and biasing, large input impedance which may be more than 100 megaohms. The *FET* is generally much less noisy than the ordinary or bipolar transistor.

Types of FET

18

- There are two basic types of field effect transistors
 - (i) *Junction Field Effect Transistor (JFET)*
 - (ii) *Metal-Oxide Semiconductor FET (MOSFET)*
- The need for *FET* arose because there were many functions in which bipolar transistors were unable to replace vacuum tubes. Owing to their extremely high input impedance, *FET* devices are more like vacuum tubes than are bipolar devices and hence are able to take over many vacuum-tube functions.



Typical Field Effect
Transistor

06/08/2022

Types of FET

19

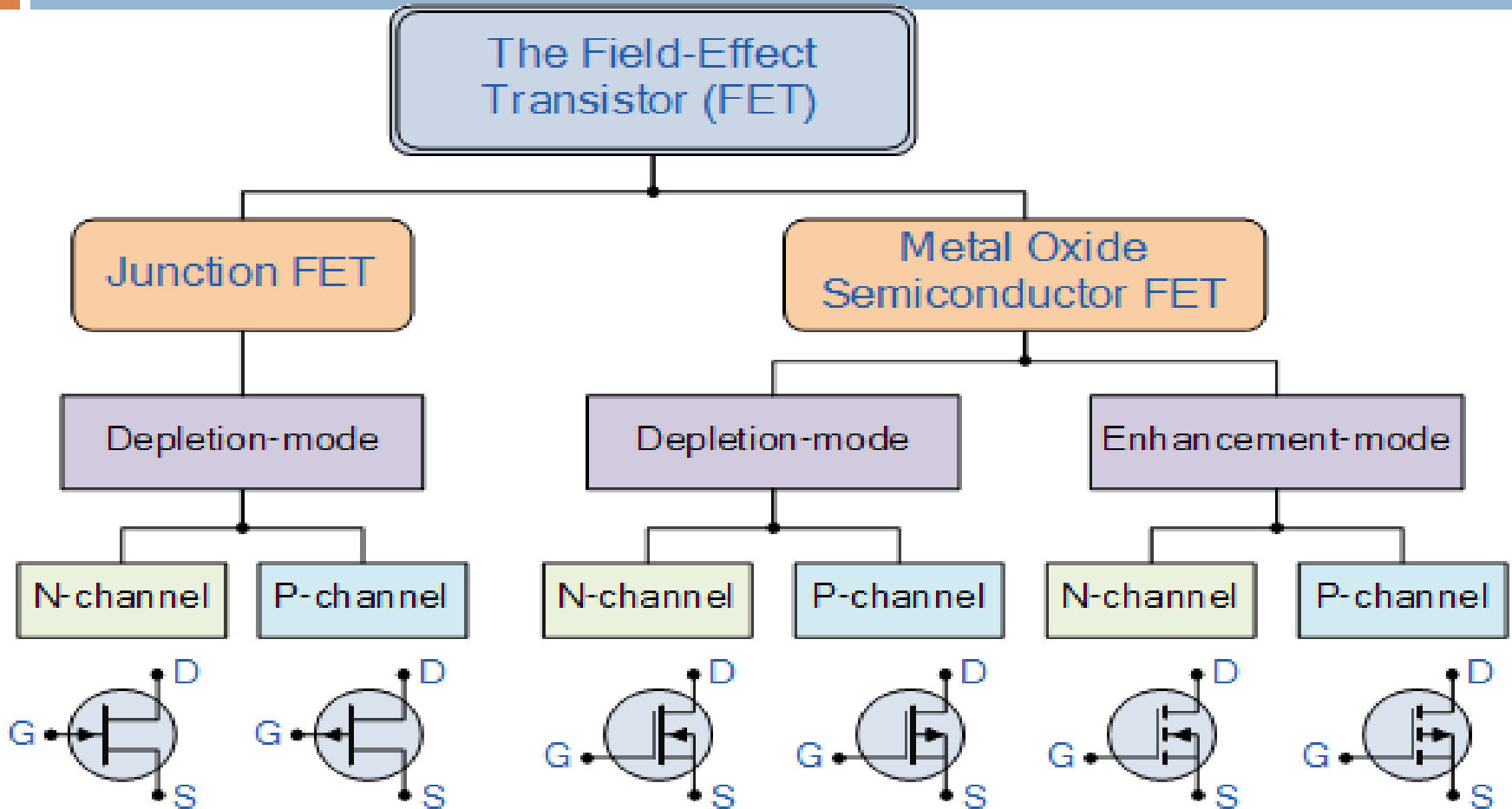

Source: https://www.electronics-tutorials.ws/transistor/tran_8.html

06/08/2022

JUNCTION FIELD EFFECT TRANSISTOR (JFET)

20

A *JFET* consists of a *p-type* or *n-type* bar containing two *pn* junctions at the sides as shown in figure below. The bar forms the conducting channel for the charge carriers. If the bar is of *n-type*, it is called *n-channel JFET* as shown in Figure below (i) and if the bar is of *p-type*, it is called *p-channel JFET* as shown in Figure (ii).

The two *pn* junctions forming diodes are connected internally and a common terminal called *gate* is taken out. Other terminals are *source* and *drain* taken out from the bar as shown. Thus a *JFET* has essentially three terminals *gate (G)*, *source (S)* and *drain (D)*.

JFET(cont'd)

21

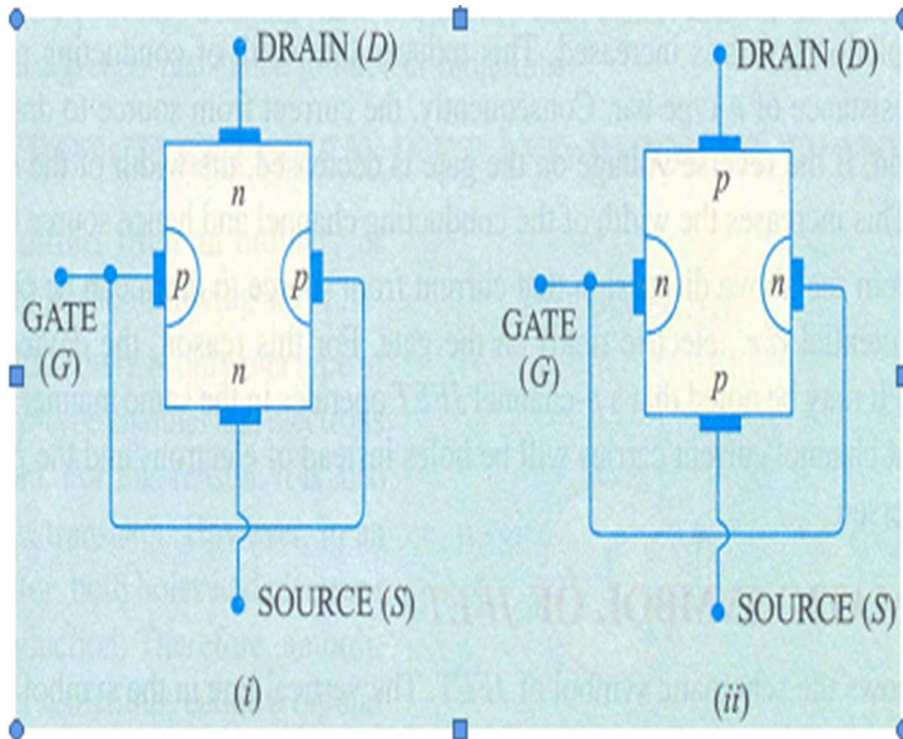

SCHEMATIC SYMBOL OF JFET

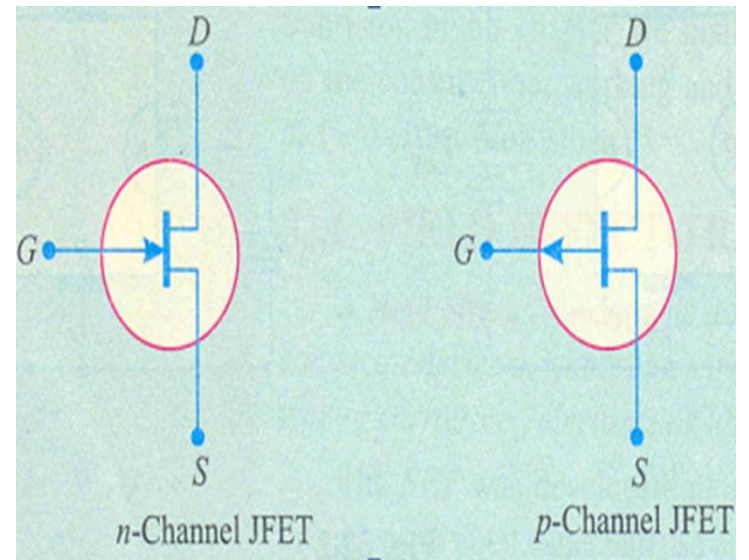

Source: Starting Electronics, Keith Brindley (Fourth Edition), published by Elsevier Ltd, 2011.

06/08/2022

METAL OXIDE SEMICONDUCTOR FET (MOSFET)

22

Metal oxide semiconductor field effect transistor is an important semiconductor device and is widely used in many circuit applications. *n-channel MOSFET* is similar to *JFET* except with the following modifications:

- i) There is only a single p-region. This region is called *substrate*.
- ii) A thin layer of metal oxide (usually silicon dioxide) is deposited over the top side of the channel. A metallic gate is deposited over the oxide layer. As silicon dioxide (SiO_2) is an insulator, therefore, gate is insulated from the channel. For this reason, MOSFET is sometimes called *insulated gate FET*.
- iii) Like a JFET, a MOSFET has three terminals *source*, *gate* and *drain*.

They are of two types:

n-channel MOSFET and p-channel MOSFET.

Difference between N and P-channel MOSFET

23

What is the difference between N and P-channel MOSFET?

N-Channel MOSFETs use electron flow as the charge carrier. **P-Channel MOSFETs** use hole flow as the charge carrier, which has less mobility than electron flow. And therefore, they have higher resistance and are less efficient. In other words, a **P-Channel MOSFET** will get hotter than an **N-Channel MOSFET** with higher loads.

MOSFET

24

n-channel MOSFET

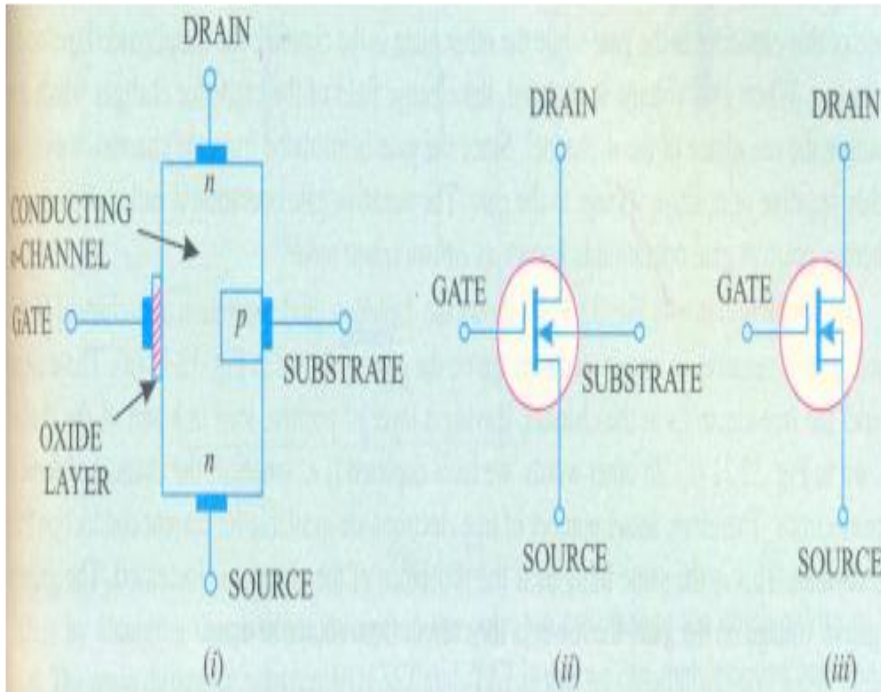

p-channel MOSFET

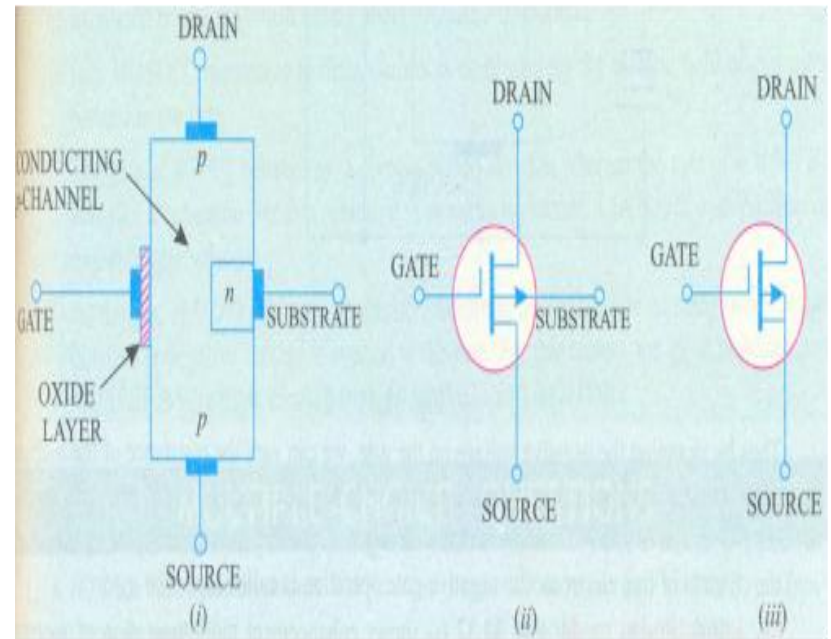

Source: Starting Electronics, Keith Brindley (Fourth Edition), published by Elsevier Ltd, 2011.

06/08/2022

Difference between BJT and FET

25

	Field Effect Transistor (FET)	Bipolar Junction Transistor (BJT)
1	Low voltage gain	High voltage gain
2	High current gain	Low current gain
3	Very high input impedance	Low input impedance
4	High output impedance	Low output impedance
5	Low noise generation	Medium noise generation
6	Fast switching time	Medium switching time
7	Easily damaged by static	Robust
8	Some require an input to turn it "OFF"	Requires zero input to turn it "OFF"
9	Voltage controlled device	Current controlled device

Source: https://www.electronics-tutorials.ws/transistor/tran_8.html

UJT

26

- The UJT is a three-terminal device. It is composed of a bar of N-type silicon with a P-type connection in the middle. The connections at the ends of the bar are known as bases B_1 and B_2 ; the P-type mid-point is the emitter.

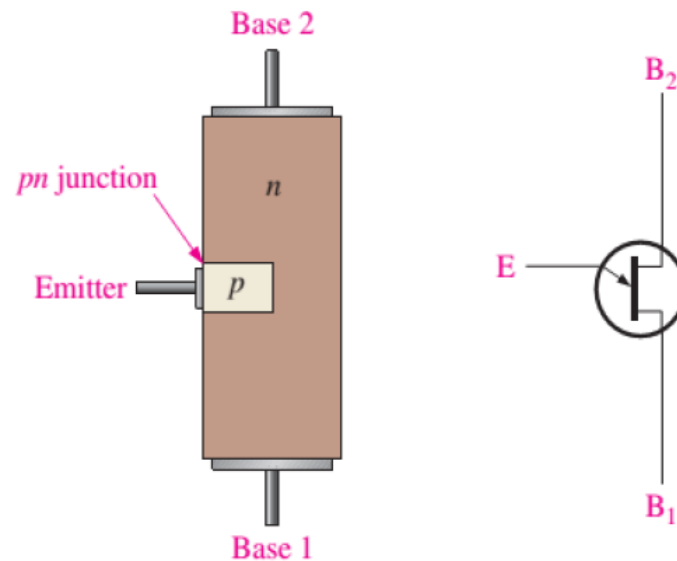

UJT Equivalent circuit

27

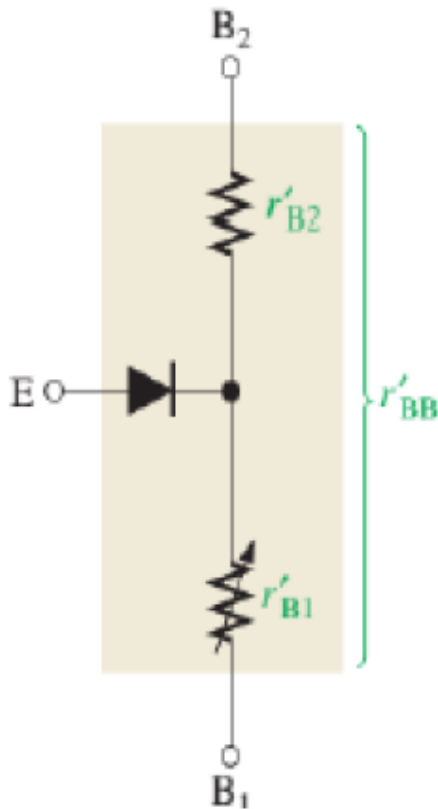

- The equivalent circuit for the UJT is shown. The total resistance between the base terminals is the sum of the dynamic resistances r'_{B1} and r'_{B2} and is called the interbase resistance r'_{BB} . The ratio $\eta = r'_{B1} / r'_{BB}$ is called a

UJT standoff ratio.

- *When the emitter voltage reaches V_P (the peak point), the UJT "fires", where*

$$V_P = V_{Pn} + \eta V_{BB}$$

UJT Characteristic curve

28

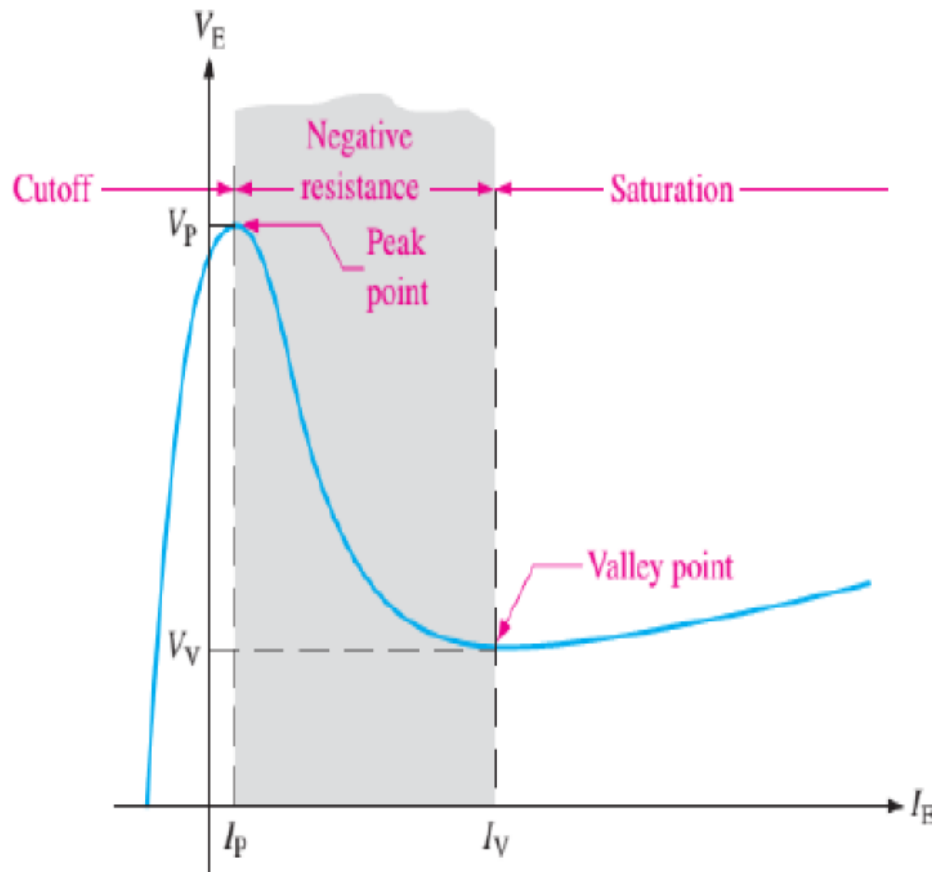

The UJT operates in a negative resistance region up to a certain value of I_E (valley point). Beyond the valley point, the device is in saturation, and V_E increases very little with an increasing I_E .

UJT Applications

29

- The UJT can be used as a trigger device for SCRs and triacs. Other applications include nonsinusoidal oscillators, sawtooth generators, phase control, and timing circuits. The figure shows a UJT relaxation oscillator as an example of one application.

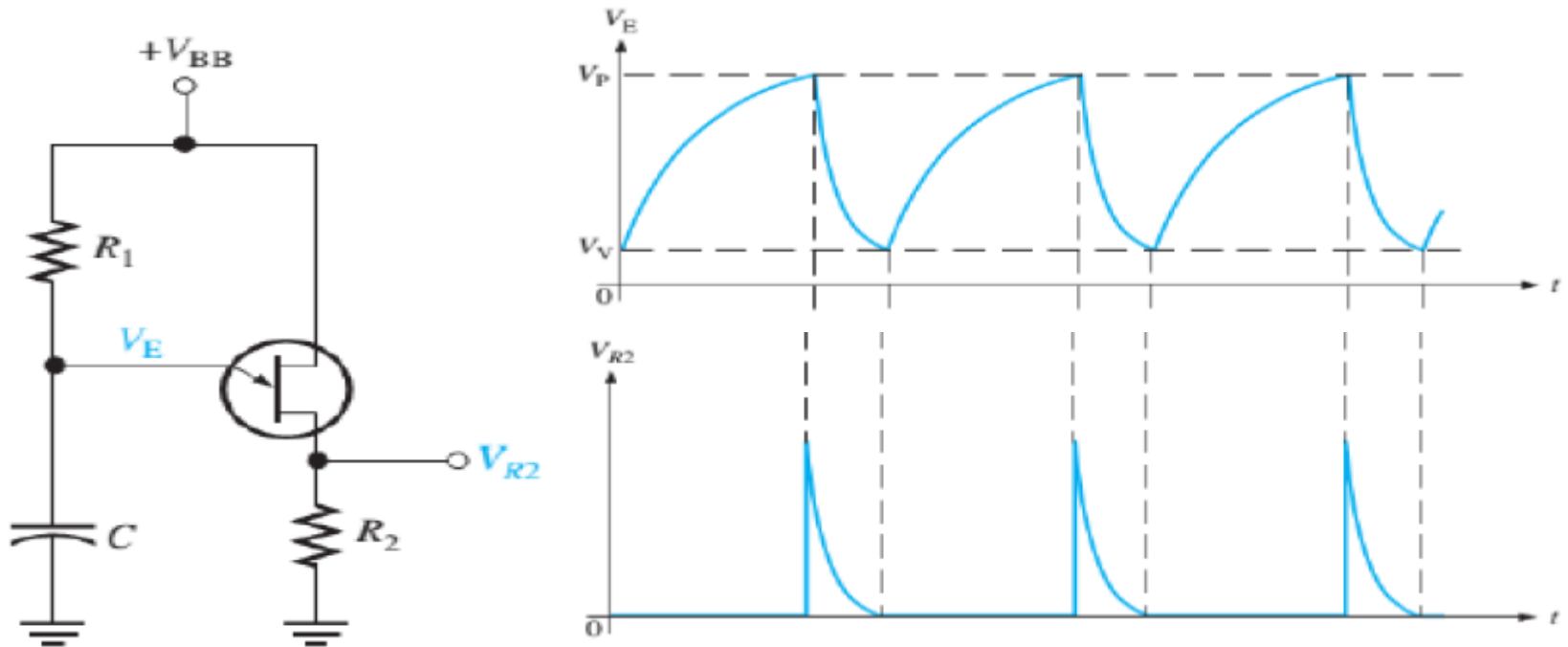

Source: <https://electricalfundablog.com/unijunction-transistor-ujt-construction-working-characteristics-curve-applications/>
06/08/2022

UJT Applications

When dc power is applied, the capacitor C charges until it reaches the peak-point voltage. At this point, the pn junction becomes forward-biased, and the emitter characteristic goes into the negative resistance region. The capacitor quickly discharges through the forward-biased junction.

When the capacitor voltage decreases to the valley-point voltage the UJT turns off, the capacitor begins to charge again, and the cycle is repeated. During the discharge time of the capacitor, the UJT is conducting.

IGBT (INSULATED GATE BIPOLAR TRANSISTOR)

31

IGBT stand for Insulated Gate Bipolar Transistor. It is a three terminal semiconductor switching device that can be used for fast switching with high efficiency in many types of electronic devices.

IGBT requires only a small voltage to maintain conduction in the device unlike in BJT. The IGBT is a unidirectional device that is, it can only switch ON in the forward direction. This means current flows from the collector to the emitter unlike in MOSFET, which are bi-directional.

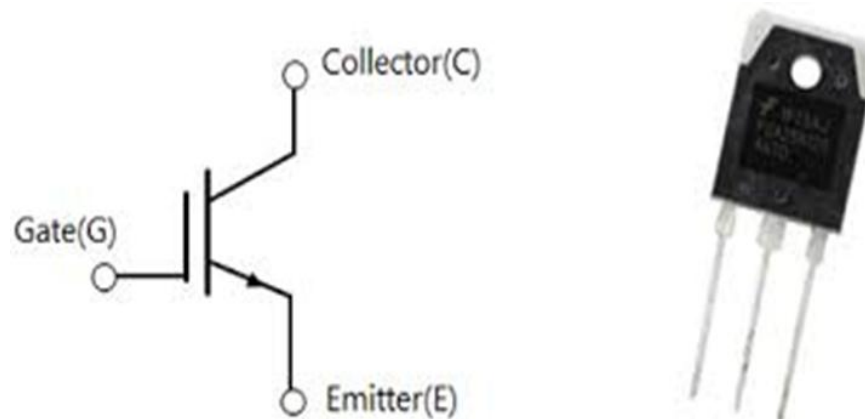

Source: <https://www.electronics-tutorials.ws/power/insulated-gate-bipolar-transistor.html>

06/08/2022

IGBT cont'

32

- IGBT is a three terminal power semiconductor switch used to control the electrical energy.
- Both Power BJT and Power MOSFET have their own advantages and disadvantages.
- BJTs have lower conduction losses in on state condition, but have longer turn off time.
- MOSFETs have higher on state conduction losses and have lower turn on and turn off times.
- The combination of BJT and MOSFET monolithically leads to a new device called **Insulated Gate Bipolar Transistor**.

IGBT cont'

33

- The other names of this device are GEMFET (Gain-Enhanced Modulated FET), COMFET (Conductivity Modulated Field Effect Transistor), IGT (Insulated Gate Transistor), bipolar mode MOSFET, bipolar MOS Transistor.
- It has superior on-state characteristics, good switching speed and excellent safe operating area.

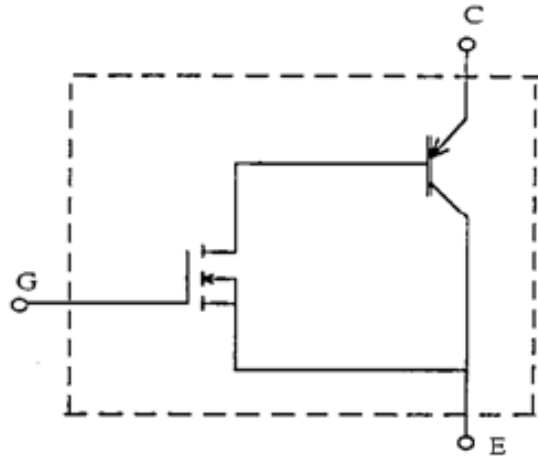

Source: <https://www.electronics-tutorials.ws/power/insulated-gate-bipolar-transistor.html>

06/08/2022

IGBT cont'

34

IGBT applications :

- DC and AC motor drives,
- Medium power supplies,
- Solid state relays,
- Inverters, UPS,
- welder equipments,
- Robotics
- Etc.

Selection of transistor based on Specifications & rating

35

- Type number
- Polarity
NPN and PNP
- Material
- Breakdown voltage
- Collector emitter current saturation
- Current gain
- Frequency transition
- Power dissipation
- Transistor coding and marking schemes
- Continuous Collector current (**IC**) is 3A.
- Collector-Emitter voltage (**VCE**) is 50 V.
- Collector-**Base** voltage (**VCB**) is 50 V.
- Emitter **Base** Voltage (**VBE**) is 4V.
- DC Current Gain (**hfe**): 35 to 320.

eg; BC107, BC109, 2N2222A

Selection of transistor based on Applications

36

- **Transistors** are commonly used in digital circuits as electronic switches which can be either in an "on" or "off" state, both for high-power **applications** such as switched-mode power supplies and for low-power **applications** such as logic gates. They are also used in:
 - Amplifiers
 - Limiting power levels
 - etc.

Selection of thyristors based on Specifications & rating

37

Voltage Ratings of SCR

The voltage capability of the SCR should not be exceeded during the operation even for short periods. So the SCR is assigned with different voltage ratings, which are the maximum voltages at which the SCR can function normally without breakdown of junctions. These are assigned in both blocking states of an SCR and can withstand against voltage transients. The various voltage ratings of an SCR are given below.

Peak Working Forward-blocking Voltage V_{DWM}

It specifies the maximum instantaneous value of forward blocking voltage across the SCR excluding all surge and repetitive transient voltages. Beyond this value of the voltage the SCR cannot withstand during its operation.

References

Fundamentals of electronics. Book 1, Electronic devices and circuit applications, Thomas F. Schubert, Jr. and Ernest M. Kim.,an Rafael, California (1537 Fourth Street, San Rafael, CA 94901 USA) : Morgan & Claypool, 2014.

Principles of Electrical Engineering. Wiley., 1922.

Starting Electronics, Keith Brindley (Fourth Edition), published by Elsevier Ltd, 2011.

<https://www.electricaltechnology.org/2021/04/difference-npn-pnp-transistor.html>

<https://www.physics-and-radio-electronics.com/electronic-devices-and-circuits/transistors/bipolarjunctiontransistor/bjtoperationmodes.html>

https://www.electronics-tutorials.ws/transistor/tran_8.html

<https://electricalfundablog.com/unijunction-transistor-ujt-construction-working-characteristics-curve-applications/>

<https://www.electronics-tutorials.ws/power/insulated-gate-bipolar-transistor.html>