

1-Mavzu: Kirish. O'zgarmas tok zanjiri. Asosiy tushunchalar.

(Lecture-1: DC Circuits. Basic Concepts)

1-Mavzuning 2-qismi

(Part 2 of the Lecture-1)

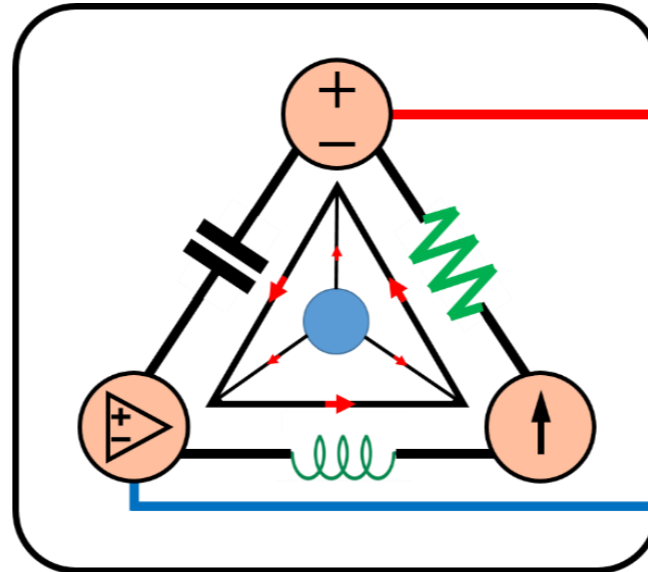

Lecturer: Yusupov Sarvarbek

*Toshkent Kimyo Xalqaro Universiteti
"Mashinasozlik texnologiyasi" kafedrasida
Toshkent shahri, Usmon Nosir, 156-uy.*



1-Mavzu: Kirish. O'zgarmas tok zanjiri. Asosiy tushunchalar.

(Lecture-1: DC Circuits. Basic Concepts)

O'quv rejasi:

1.1. Kirish.

1.2. Fanning maqsad va vazifalari.

1.3. Elektr zanjirlarida birliklar tizimi.

1.4. Elektr zanjirlarni tavsiflovchi asosiy kattaliklar va uning elementlari.

1.5. Elektr zaryad va tok kuchi.

1.6. Elektr kuchlanish.

1.7. Quvvat va energiya.

1.8. Elektr zanjiridagi manba elementlarining turlari.

1.9. Qo'llanishishi.

1.4. Elektr zanjirlarni tavsiflovchi asosiy kattaliklar va uning elementlari.

Ma'lumki, ikki jism bir-biriga faqat sirlari orqali ta'sir etadi. Magnit maydonini o'zgarishi natijasida elektr maydoni va aksincha elektr maydonini o'zgarishi natijasida magnit maydoni hosil bo'lishi bu ikki maydonning o'zaro bog'liqligini bildiradi.

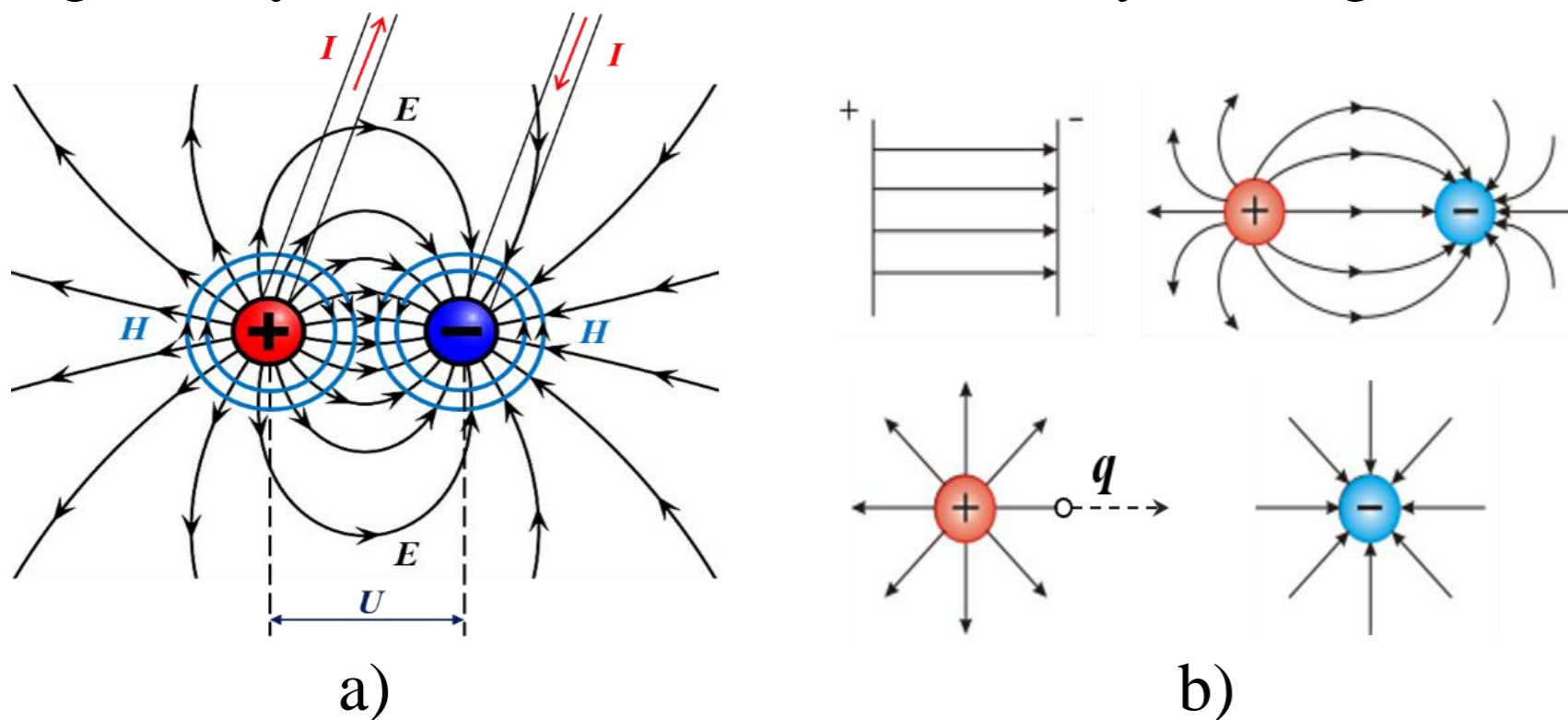

1.2-rasm. Elektr maydoni.

- a) Qo'zg'almas zaryadlangan zarracha atrofida elektr maydon hosil bo'lishi.
- b) Elektr maydonida elektr tokining harakat yo'nalishi.







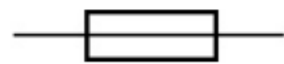

Photo source: [18] - https://upload.wikimedia.org/wikipedia/commons/thumb/e/ed/VFPt_charges_plus_minus_thumb.svg/1200px-VFPt_charges_plus_minus_thumb.svg.png

Tarmoq simlari orqali energiya uzatishda bir-biridan izolyatsiya qilingan simlar kuchlanish (U) ta'sirida bo'ladi.

Buning natijasida simlar orasida kuchlanganligi bo'lgan elektr maydoni (E) hosil bo'ladi.

Tarmoq simlaridan tok (I) o'tishi natijasida ularning ichida va atrofida kuchlanganligi bo'lgan magnit maydoni (H) yuzaga keladi.

elementlarni shartli belgilanishlari.

Nomlanishi	Belgilanishi
O'zgarmas tok elektr generator	
Birlamchi element yoki akkumulyator	
O'zgarmas tok elektr dvigateli	
Elektr lampochkasi	
Birlashtiruvchi sim	
Bir qutbli rubilnik	
Saqlagich	
Ampermetr / Voltmetr	

Elektr energiya manbai – EYuK ni qiymati, yo‘nalishi va ichki qarshiligining miqdori bilan tavsiflanadi. Elektr zanjirning elementlari shartli belgilar bilan tasvirlanadi:

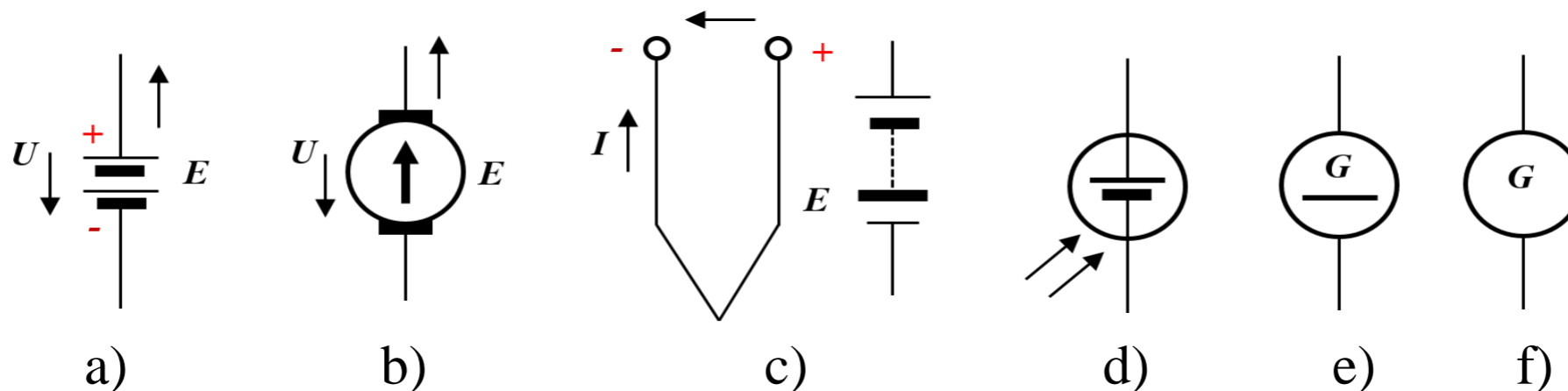

1.3-rasm. Elektr energiya manbalarining shartli belgilari.

- a) galvanik element, b) doimiy magnitli o‘zgarmas tok elektr generatori, c) termojuft, d) fotoelement, e) o‘zgarmas tokning elektr mashina generatori, f) o‘zgaruvchan tokning elektr mashina generatori.

Elektr energiya iste'molchilari (elektr motorlar, elektr ko'ralar, issiqlik asboblari, cho'g'lanish lampalari, rezistorlar va b.) elektrenergiyani boshqa tur energiyaga aylantirish uchun xizmat qiladi (1.4-rasm).

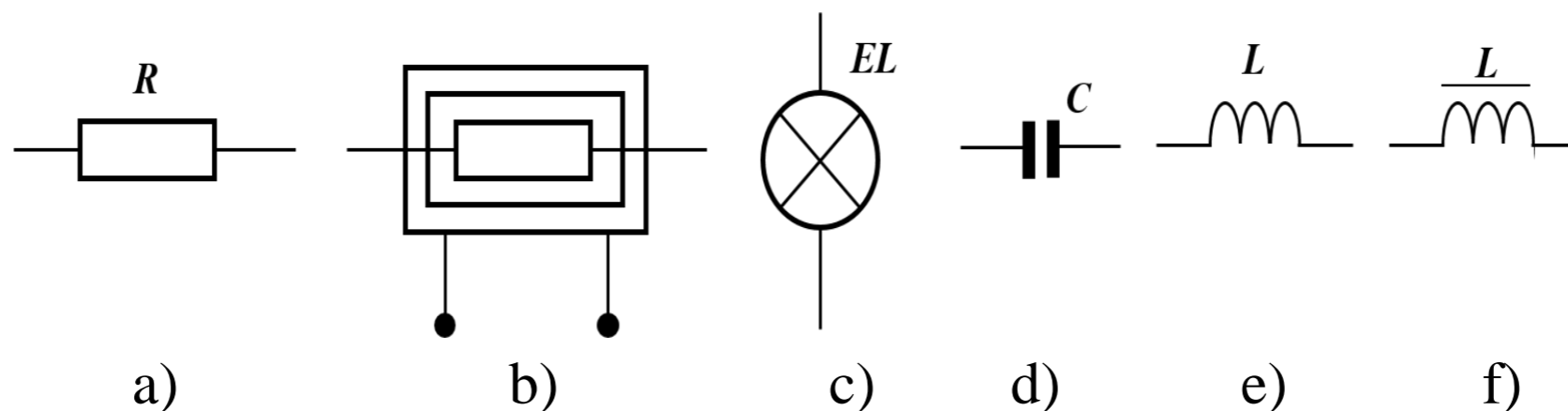

1.4-rasm. Elektr energiyasi iste'molchilarining shartli belgilari.

a) rezistor, b) elektr qizdirgich, c) cho'g'lanma lampa, d) kondensator,
e) induktiv g'altak, f) o'zakli g'altak - drossel.

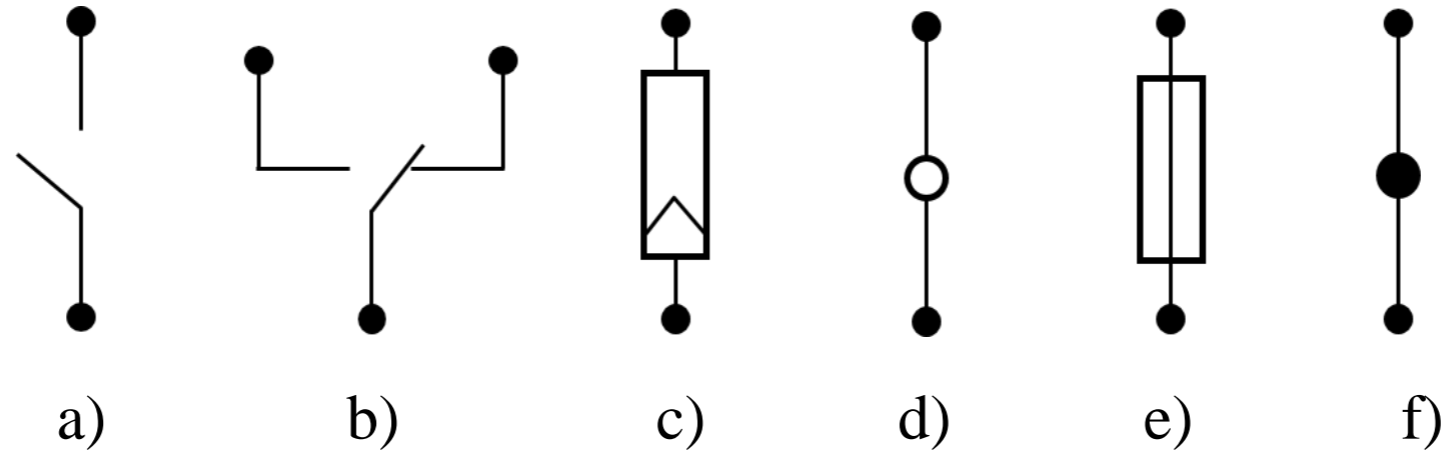

1.5-rasm. Elektr zanjir yordamchi elementlarining shartli belgilari.

a) kalit (ulab-uzgich), b) qayta ulagich, c) shtepsel,

d) ajratish mumkin bo‘lgan o‘tkazgichning ulangan joyi-qisqich,

e) eruvchan saqlagich, f) o‘tkazgichlar kavsharlanib ulangan tugun.

1.5. Elektr zaryad va tok kuchi.

Elektr zaryad – bu atomik zarrachalarning elektr xususiyati bo‘lib, ular kulonlarda (C) o‘lchanadi. Elektr zaryadlari erkin tashuvchilarining elektr maydoni ta’sirida tartibli harakatiga elektr tok deyiladi. Ya’ni, elektr toki – zaryadli zarrachalarning tartibli harakati (oqimi)dir. Elektr toki bo‘lishi uchun erkin elektr zaryadlar, elektr maydoni va elektr tok manbai.

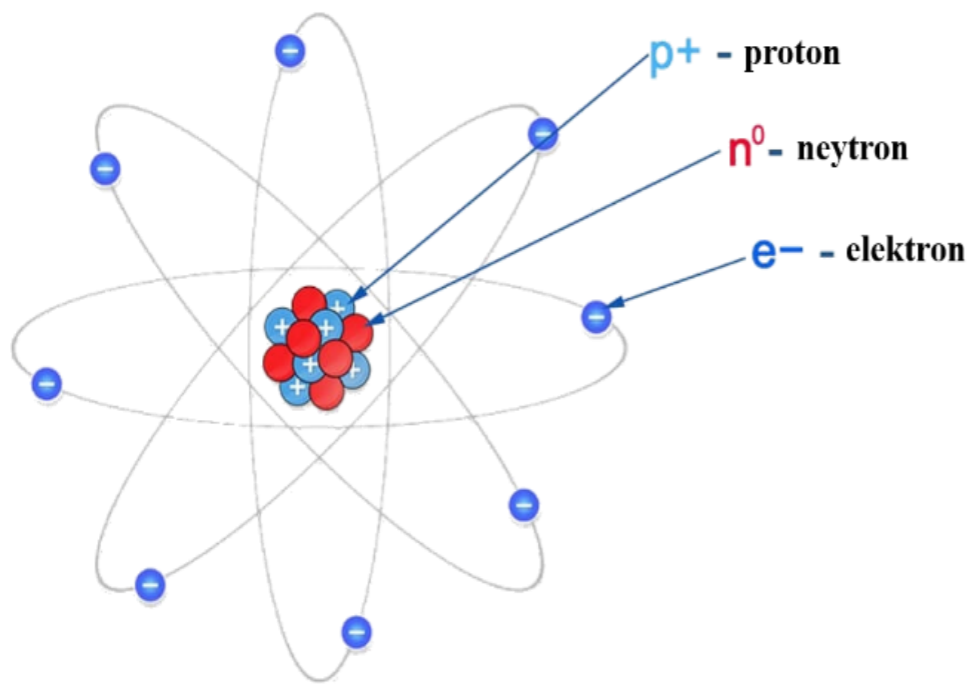

1.6-rasm. Atomning tuzilishi.

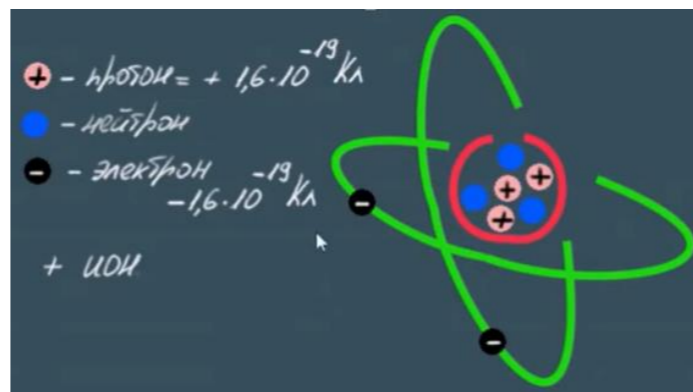

Atom elektronlarni yo‘qotsa, u “Musbat” zaryadlangan bo‘lib qoladi va “+” ion deb ataladi.

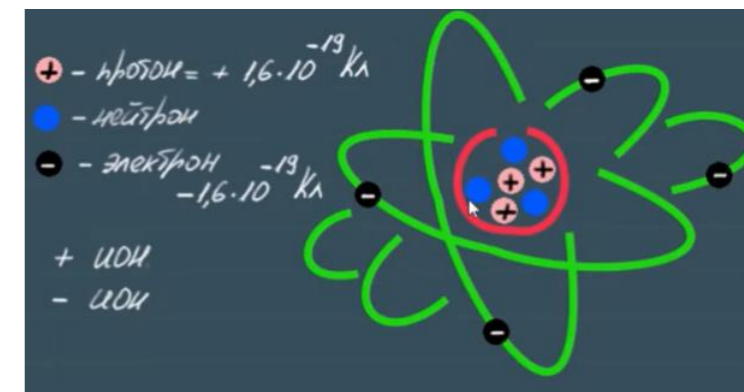

Atom qo‘shimcha elektronorttirs, u “Manfiy” zaryadlangan bo‘lib qoladi va “-” ion deb ataladi.

Elektr tokining paydo bo‘lishi to‘g‘ridan-to‘g‘ri atom va elektronga bog‘liq.

Photo source: [19] - <https://www.youtube.com/watch?v=P6B58PX9q4o>



Eksperimental kuzatishlarga ko'ra, tabiatda uchraydigan barcha elektronlarning

zaryad miqdori $e = -1,602 \cdot 10^{-19} \text{ C}$ ga teng.

3. Zaryadning saqlanish qonuni shuni ko'rsatadiki, zaryad hosil bo'lishi yoki yo'q qilinishi ham mumkin emas, faqat uni o'tkazish mumkin. Shunday qilib, tizimdagi elektr zaryadlarining algebraik yig'indisi o'zgarmaydi.

1.5.1-masala: 4600 ta elektron qancha zaryad bilan ifodalanadi?

Yechish: Har bir elektron $-1,602 \cdot 10^{-19} \text{ C}$ ga teng deb hisoblasak,

$$-1,602 \cdot 10^{-19} \frac{\text{C}}{\text{elektron}} \cdot 4600 \text{ elektronlar} = -7,369 \cdot 10^{-16} \text{ C}$$

Shunday qilib, Tok kuchi – amper (A) da o‘lchanadigan zaryadning o‘zgarish tezligi. Matematik jihatdan elektr toki (A), elektr zaryadi (C) va vaqt (s) o‘rtasida o‘zaro bog‘liqlik mavjud.

Tok kuchi deb, o‘tkazgichning ko‘ndalang kesim yuzidan vaqt birligi ichida o‘tgan elektr zaryadiga miqdor jihatdan teng bo‘lgan fizik kattalikka aytiladi, yani:

$$i = \lim_{\Delta t \rightarrow 0} \frac{\Delta q}{\Delta t} = \frac{dq}{dt}$$

bu yerda: i – tok kuchi, q – elektr zaryad, t – elektr zaryad o‘tishi uchun ketgan vaqt.



1.5.2-masala: Terminalga kiradigan umumiy zaryad $q = 5t \sin 4\pi t \text{ mC}$ bilan

berilgan. $t = 0,5 \text{ s}$ dagi tok kuchini hisoblang.

Yechish:

$$i = \frac{dq}{dt} = \frac{d}{dt} (5t \sin 4\pi t) \text{ mC/s} = (5 \sin 4\pi t + 20\pi t \cos 4\pi t) \text{ mA}$$

$t = 0,5 \text{ s}$ da

$$i = 5 \sin 2\pi + 10\pi t \cos 2\pi = 0 + 10\pi = 31,42 \text{ mA}$$

Vaqt bo'yicha qiymati va yo'nalishi o'zgarmaydigan tok o'zgarmas tok (DC – direct current) deb ataladi (1.7- a, rasm). Vaqt bo'yicha o'zgaradigan tok o'zgaruvchan tok (AC – alternating current) deb ataladi (1.7- b, rasm). I belgisi o'zgarmas tokini ifodalash uchun ishlatiladi. O'zgaruvchan tokni ifodalashda esa i ishlatiladi. Uning keng tarqalgan shakli sinusoidal oqimdir.



a)

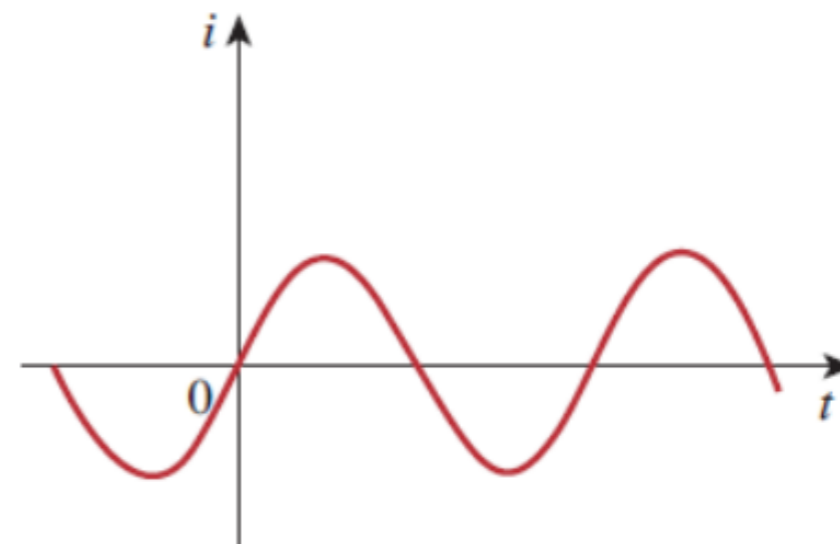

b)

1.7-rasm. Elektr tokining turlari.

a) o'zgarmas tok. b) o'zgaruvchan tok.

1.6. Elektr kuchlanish.

Elektronlar dreyf paytida ma'lum bir darajadagi titrash holatida bo'ladi. Ushbu holat elektr yurituvchi kuch (EYuK) deb nomlanadi. Uning birligi Volt. Sodda qilib aytganda EYuK bu – elektronlarning o'z o'rnini tark etishga bo'lgan ishtiyoq darajasidir.

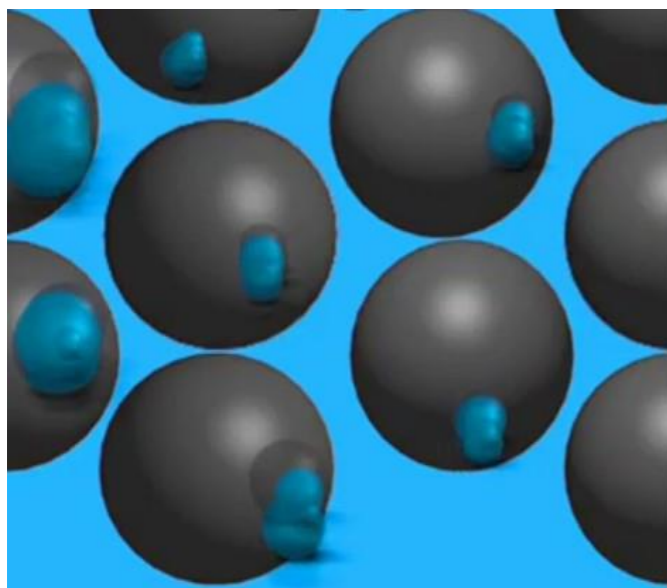

a)

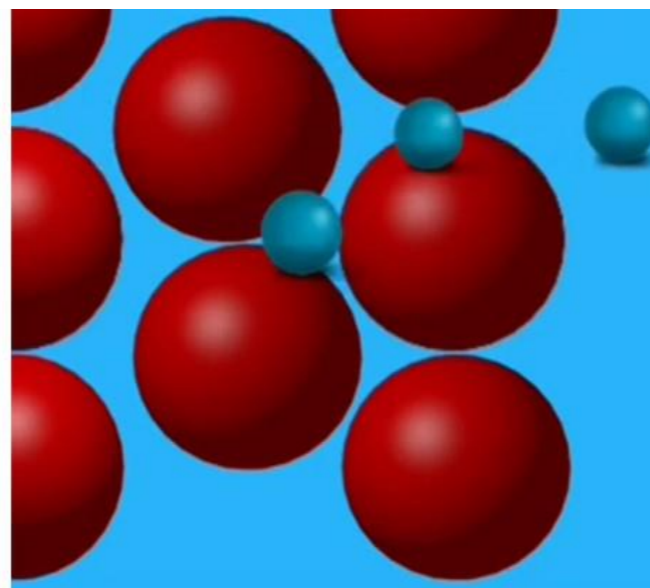

b)

1.8-rasm.

a) elektr yurituvchi kuch; b) kuchlanish.

EYuK – elektron o'z atomini tark etish va erkin dreyf paytidagi tebranish darajasi bo'lsa, kuchlanish – elektronlarning tartibli harakati paytidagi tebranish darajasidir.



EYuKning kuchlanish holatiga o'tishi uchun ya'ni, elektronning ma'lum yo'nalish bo'yicha

harakatni boshlashi uchun yopiq zanjir, yopiq kontur talab etiladi.

Elektronni o'tkazgichdagi ma'lum bir yo'nalishda harakatlantirish uchun ba'zi ish yoki energiya uzatish talab etiladi. Ushbu ish tashqi EYuK kuchlanish yoki potensial farq sifatida ham tanilgan. Elektr zanjiridagi ikkita a va b nuqta orasidagi U_{ab} kuchlanish birlik zaryadini a dan b ga ko'chirish uchun zarur bo'lgan energiya (yoki ish)ni ifodalaydi. Bu tushunchani matematik jihatdan quyidagicha yozishimiz mumkin:

$$U_{ab} \triangleq \frac{dw}{dq}, \quad \left[\frac{J}{C} = \frac{N \cdot m}{C} = V \right]$$

bu yerda: w - jouldagi energiya (J) va q - kulondagi zaryad (C).

Kuchlanish (yoki potensial farq) - bu birlik zaryadni element orqali ko‘chirishida bajargan ishga

teng bo‘lgan fizik kattalikdir.

U_{ab} ikki shaklda talqin qilinishi mumkin: a nuqtadagi U_{ab} ning potensial kuchlanishi b nuqtadan ko‘ra yuqori; b nuqtaga nisbatan a nuqtadagi potensial U_{ab} dir.

Umuman olganda, mantiqan shunday bo‘ladi.

$$U_{ab} = -U_{ba}$$

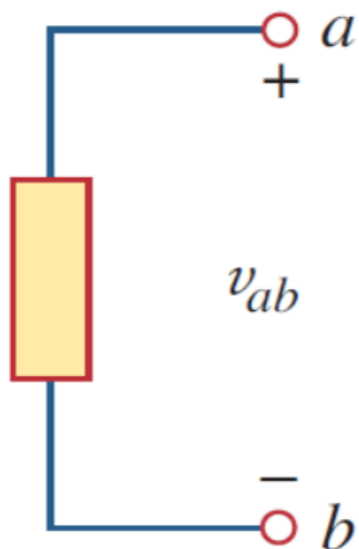

1.9-rasm. U_{ab} kuchlanishning qutblari.

1.10-rasm, a da a dan b gacha 9 V kuchlanish pasayishi yoki ekvivalent b dan a ga 9 V kuchlanishga ko‘tariladi. Boshqacha qilib aytganda, a dan b gacha bo‘lgan kuchlanishning pasayishi b dan a gacha bo‘lgan kuchlanishning oshishiga tengdir.

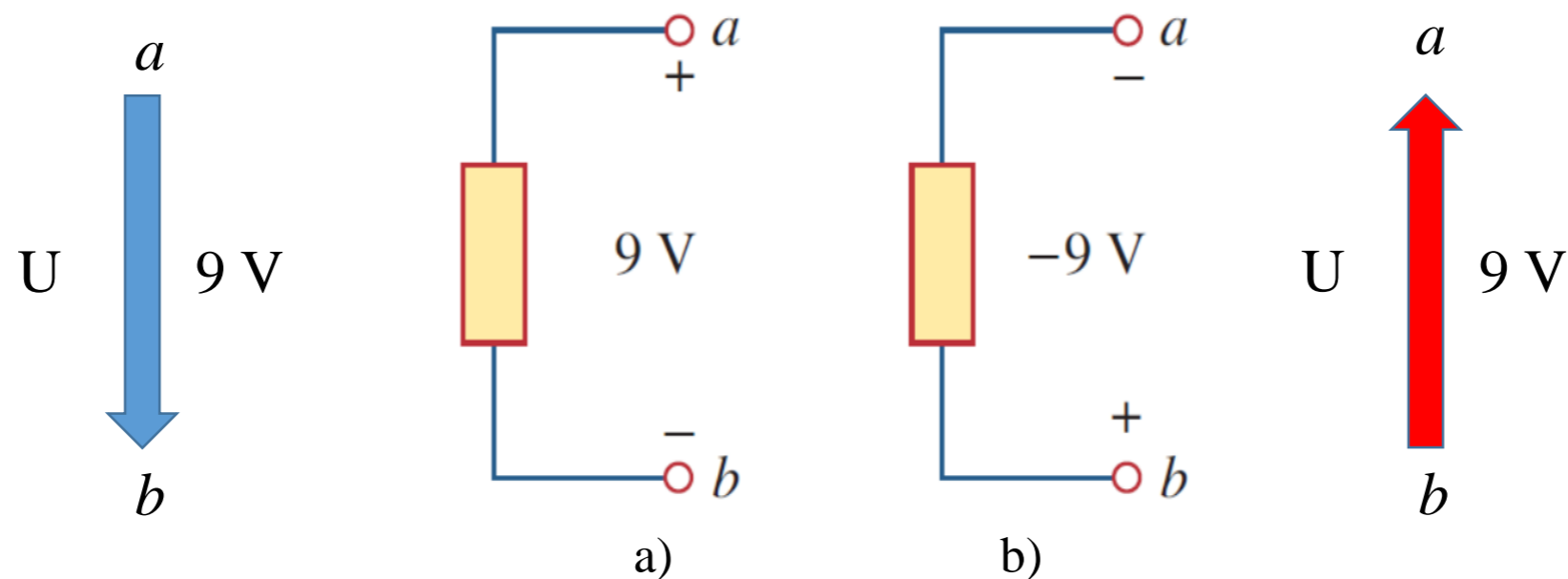

1.10-rasm. Bir xil U_{ab} kuchlanishning ikkita ekvivalent ko‘rinishi:

a) a nuqta b nuqtadan 9 V yuqori; b) b nuqta a nuqtadan -9 V yuqori.



Photo source: [21] - <https://cdn-icons-png.flaticon.com/512/551/551080.png>

elektr toki har doim element orqali o'tadi

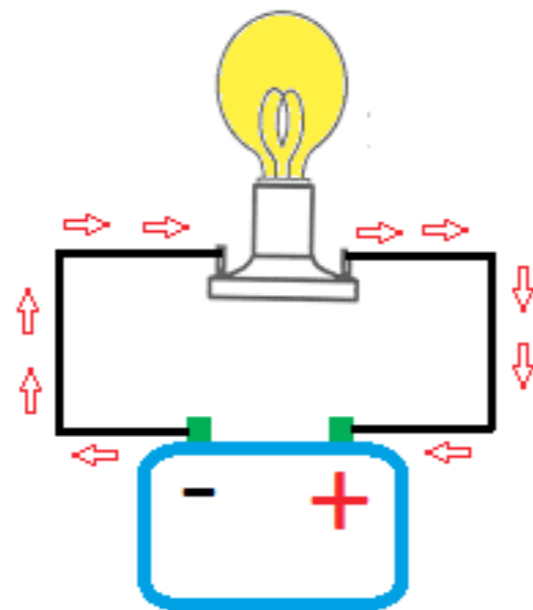

Photo source: [22] - <https://www.basic-mathematics.com/images/flow-of-electric-charge.png>

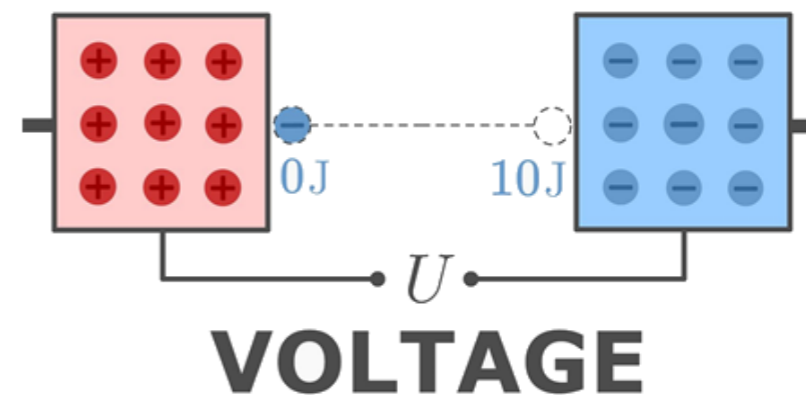
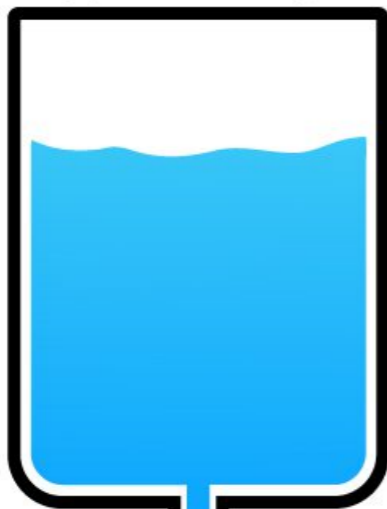

Photo source: [23] - <https://www.youtube.com/watch?v=uLoRL2Zjn9w>

elektr kuchlanish har doim element bo'ylab
yoki ikki nuqta o'rtasida bo'ladi.

Voltage

Voltage can be represented by the pressure in a water tank forcing water through the pipe



Current

The water flowing through the pipe represents the electrical current, the more pressure there is the more current you get



Resistor

The small diameter of the pipe restricts water flow, similar to the way a resistor restricts the current of a circuit

Photo source: [24] - <https://www.electricalengineeringinfo.com/wp-content/uploads/2016/02/water-tank2Banalogy2Bvoltage.jpg>

Comparing a DC Circuit to the Flow of Water

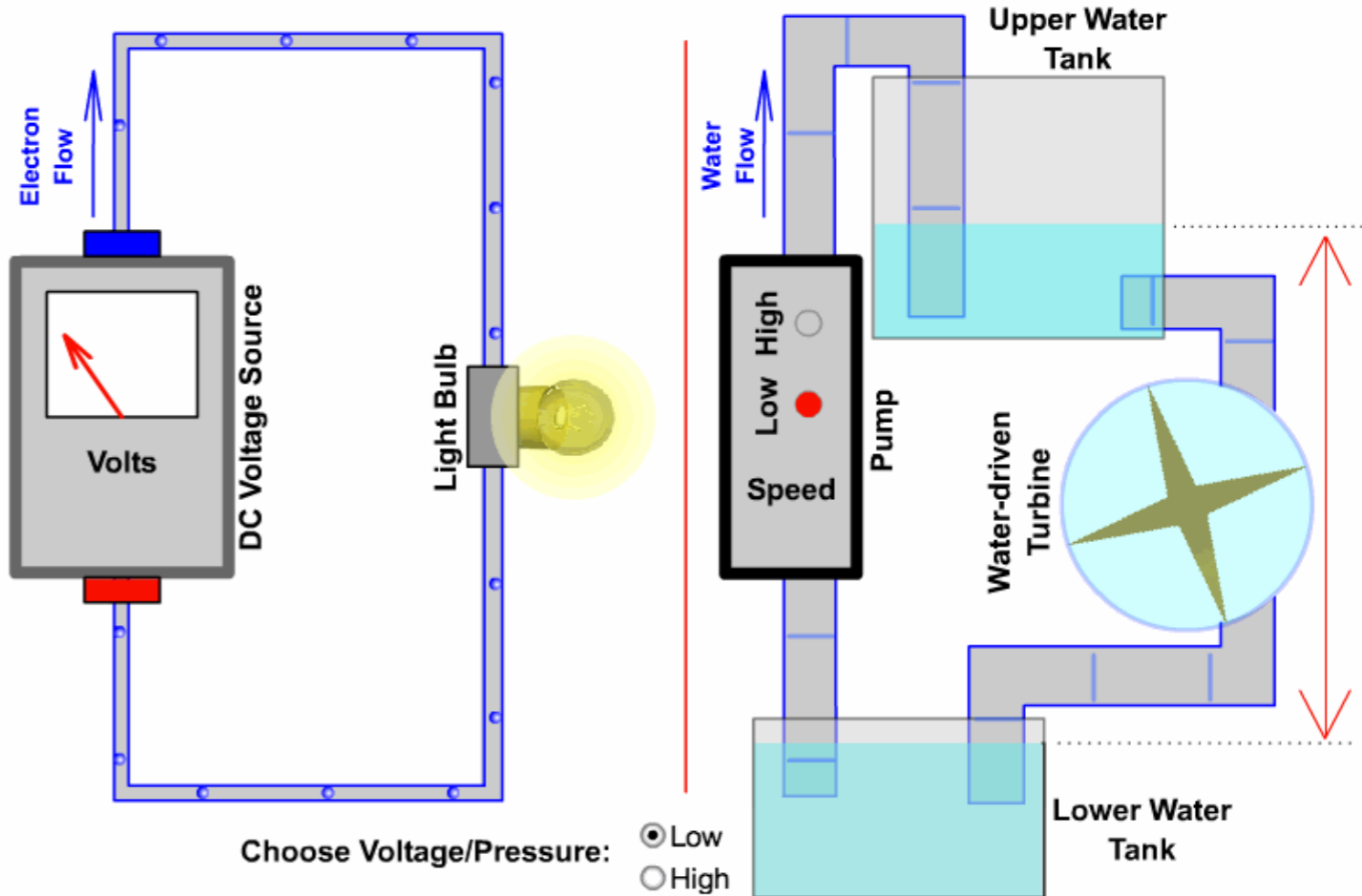
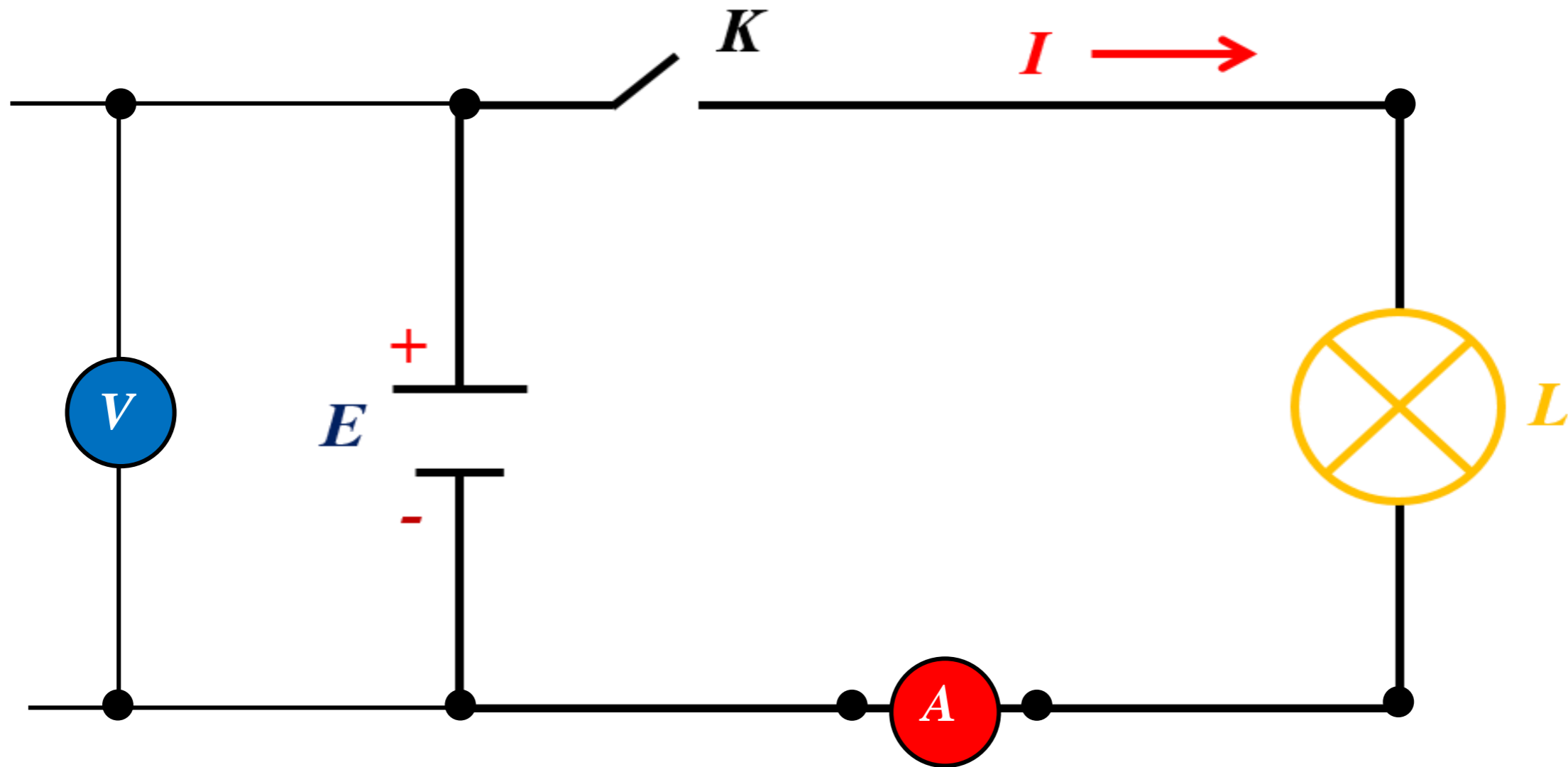

Photo source: [25] - <https://sciencepedagogy.pbworks.com/f/1382142044/water%20analogy.gif>

Tok kuchi va kuchlanishni zanjirda o`lchash usullari





1.6.1-masala: Energiya manbai lampochkadan 10 soniya davomida 2 A o‘zgaras tokni o‘tkazishga majbur qiladi. Agar yorug‘lik va issiqlik energiyasi shaklida 2,3 kJ berilsa, lampochkadagi kuchlanishning pasayishini hisoblang.

Yechish:

To‘la zaryad: $\Delta q = i \cdot \Delta t = 2 \cdot 10 = 20 \text{ C}$

Kuchlanishning pasayishi: $u = \frac{\Delta w}{\Delta q} = \frac{2,3 \cdot 10^3}{20} = 115 \text{ V}$

FOYDALANILGAN FOTO MANBAALAR:

18. https://upload.wikimedia.org/wikipedia/commons/thumb/e/ed/VFPt_charges_plus_minus_thumb.svg/1200px-VFPt_charges_plus_minus_thumb.svg.png
19. <https://www.youtube.com/watch?v=P6B58PX9q4o>
20. <https://www.youtube.com/watch?v=kBAIPEIEkr8&t=6s>
21. <https://cdn-icons-png.flaticon.com/512/551/551080.png>
22. <https://www.basic-mathematics.com/images/flow-of-electric-charge.png>
23. <https://www.youtube.com/watch?v=uLoRL2Zjn9w>
24. <https://www.electricalengineeringinfo.com/wp-content/uploads/2016/02/water-tank2Banalogy2Bvoltage.jpg>
25. <https://sciencepedagogics.pbworks.com/f/1382142044/water%20analogy.gif>



*E'TIBORINGIZ
UCHUN
RAHMAT!!!*