

5-Mavzu: Operatsion kuchaytirgichlar.

(Lecture-5: Operational Amplifiers)

5-Mavzuning 3-qismi

(Part 3 of the Lecture-5)

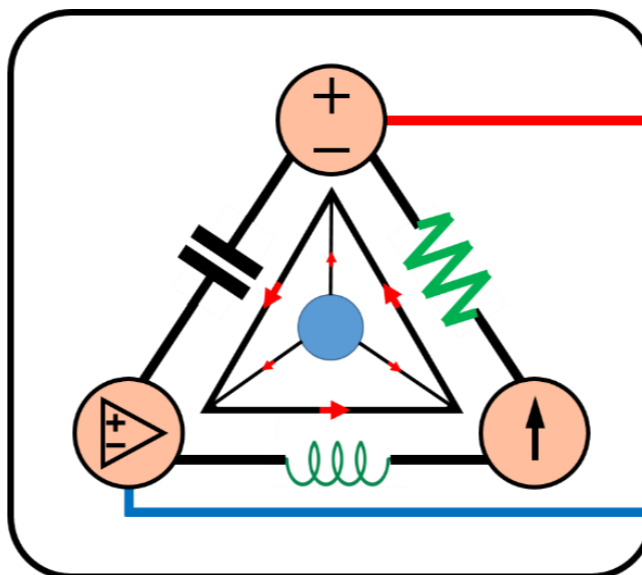

Lecturer: Ph.D., Yusupov Sarvarbek

*Toshkent Kimyo Xalqaro Universiteti
"Mashinasozlik texnologiyasi" kafedrasida
Toshkent shahri, Usmon Nosir, 156-uy.*

5-Mavzu: Operatsion kuchaytirgichlar.

(Lecture-5: Operational Amplifiers)

O'quv rejasi:

- 5.1. Operatsion kuchaytirgichlar.
- 5.2. Ideal operatsion kuchaytirgichlar.
- 5.3. Teskari (*inverting*) kuchaytirgichlar.
- 5.4. Teskari bo'lmagan (*noninverting*) kuchaytirgichlar.
- 5.5. Umumlashtirish kuchaytirgichi.
- 5.6. Farqlovchi kuchaytirgich.
- 5.7. Kaskadli operatsion kuchaytirgich zanjirlari.**
- 5.8. Qo'llanilishi.**

5.7. Kaskadli operatsion kuchaytirgich zanjirlari.

Ma'lumki, operatsion kuchaytirgich zanjirlar murakkab zanjirlarni loyihalash uchun modullar yoki bloklar sifatida ishlatiladi.

Amaliy dasturlarda ko'pincha katta umumiy kuchayishga erishish uchun operatsion kuchaytirgich zanjirlarni kaskadda (*ya'ni, boshidan oxirigacha*) ulash zarur.

Multi-stage OP-Amp Circuits (Cascaded OP-Amp's)

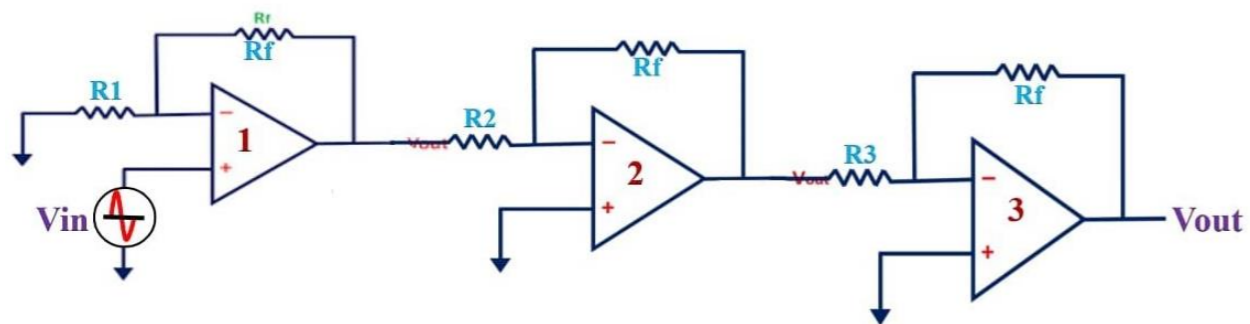

Cascading increases Bandwidth and Gain,
But more Noise and Offset voltage at the Output

Umuman olganda, ikkita zanjirlar tandem (*birgalikda*)da, bir faylda bir-biri ketma-ket ulanganda kaskadli bo'ladi.

Photo source: [17] - <https://i.ytimg.com/vi/KpBgf6ydpIc/maxresdefault.jpg>

Kaskadli ulanish ikki yoki undan operatsion kuchaytirgich zanjirlarining boshidan-oxirigacha joylashgan bo‘lib, ulardan birining chiqishi keyingisining kirishi bo‘ladi.

Operatsion kuchaytirgich zanjirlari kaskadlangan bo‘lsa, zanjirdagi har bir bosqich kaskad deb ataladi; asl kirish signali individual bosqichning ortishi bilan ortadi.

Operatsion kuchaytirgich zanjirlarining afzalligi shundaki, ular kirish-chiqish munosabatlarini o‘zgartirmasdan kaskadli bo‘lishi mumkin.

Buning sababi, har bir (*ideal*) operatsion kuchaytirgich zanjiri cheksiz kirish qarshiligi va nol chiqish qarshiligiga ega.

Bir bosqichning chiqishi keyingi bosqichga kirish bo‘lganligi sababli, kaskad ulanishining umumiy ortishi individual operatsion kuchaytirgich zanjirlarining kuchayishiga olib keladi.

$$A = A_1 A_2 A_3 \quad (5.22)$$

Kaskadli ulanish operatsion kuchaytirgich kiritish-chiqish munosabatlariga ta’sir qilmasa ham, kaskaddagi keyingi bosqichdan kelib chiqadigan yuklanish operatsion kuchaytirgichni to‘yintirmasligi uchun haqiqiy operatsion kuchaytirgich zanjirini loyihalashda ehtiyot bo‘lish kerak.

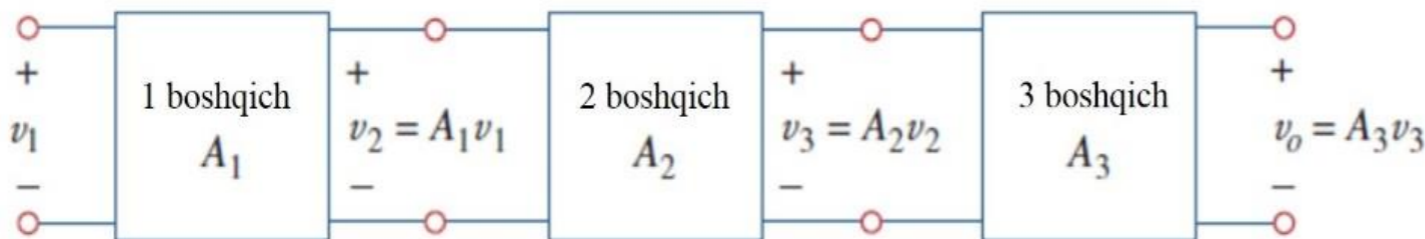

5.19-rasm. 3 boshqichli kaskadlangan ulanish.

5.7.1-masala: 5.20-rasmda keltirilgan zanjirdagi u_o va i_o ni toping.

Yechish:

Birinchi operatsion kuchaytirgichning chiqishidagi kuchlanish u_a quyidagiga teng.

$$u_a = \left(1 + \frac{12}{3}\right) 20 = 100 \text{ mV}$$

Ikkinchi operatsion kuchaytirgichning chiqishidagi kuchlanish u_o quyidagiga teng.

$$u_o = \left(1 + \frac{10}{4}\right) u_a = (1 + 2,5) 100 = 350 \text{ mV}$$

$$u_b = u_a = 100 \text{ mV}$$

$$i_o = \frac{u_o - u_b}{10} \text{ mA}$$

$$i_o = \frac{350 - 100 \cdot 10^{-3}}{10 \cdot 10^3} = 25 \mu\text{A}$$

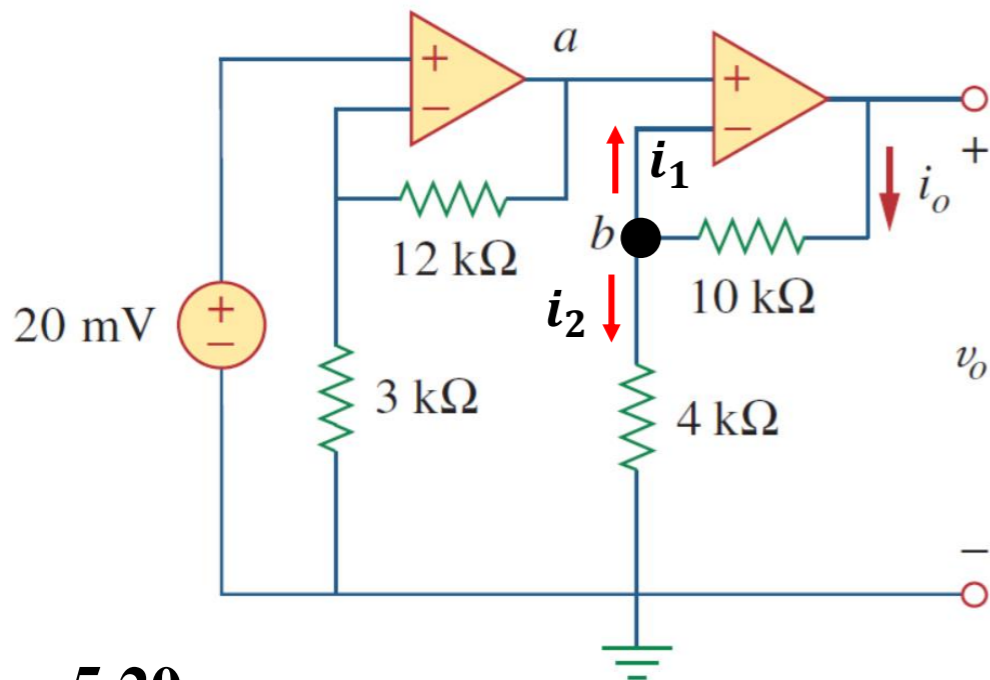

5.20-rasm.

KCL bo'yicha

$$i_o = i_1 + i_2$$

$$\sum i_{in} = \sum i_{out}$$

$$\frac{u_o - u_b}{R_{f2}} = 0 + \frac{u_b - 0}{R_2}$$

5.7.2-masala: Quyidagi Kaskadli operatsion kuchaytirgich zanjirdagi u_{o1} va u_{o2} ni toping.

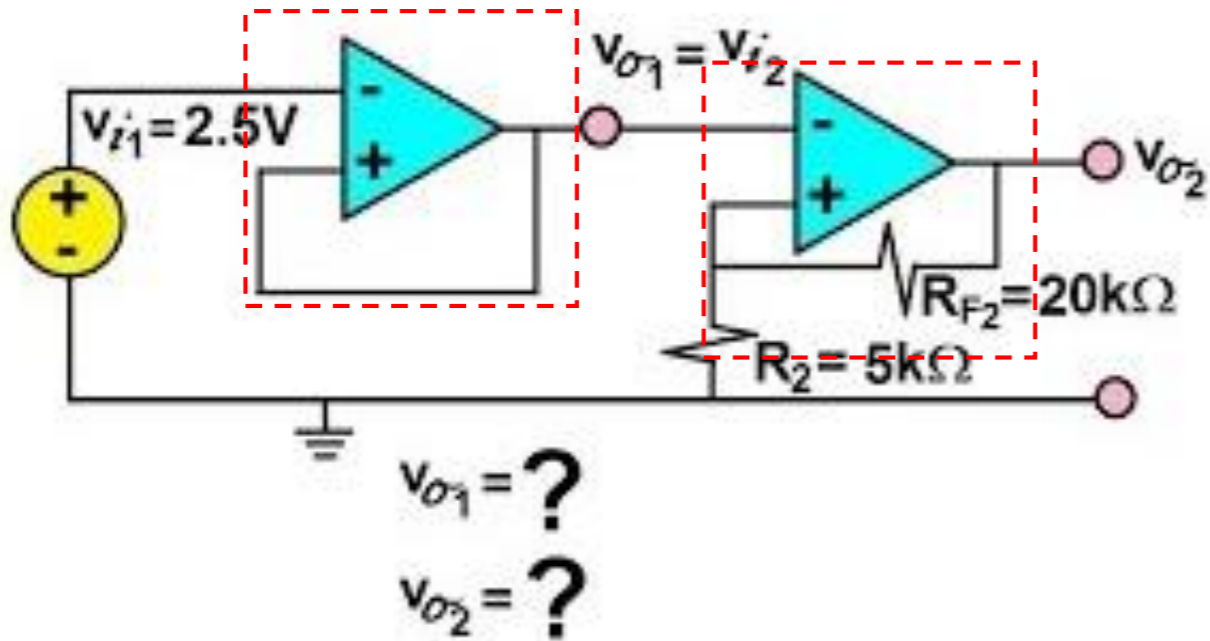

Photo source: [18] - <https://i.ytimg.com/vi/POniLEqkK7c/mqdefault.jpg>

Yechish:

Kuchlanish takrorlagich

(The voltage follower) **bo'yicha:**

$$u_i = u_o$$

$$u_{o1} = 1 \cdot u_{i1} = 1 \cdot 2,5 = 2,5 V$$

Teskari bo'lmagan (noninverting)

kuchaytirgich bo'yicha:

$$u_o = \left(1 + \frac{R_f}{R_1}\right) u_i$$

$$u_{o2} = \left(1 + \frac{R_{f2}}{R_2}\right) u_{i2} = \left(1 + \frac{20}{5}\right) 2,5 = 5 \cdot 2,5 = 12,5 V$$

5.8. Qo'llanilishi.

Operatsion kuchaytirgich zamonaviy elektron asboblarda asosiy element bloki hisoblanadi. Rezistorlar va boshqa passiv elementlar bilan birga ko'plab qurilmalarda keng qo'llaniladi.

Uning ko'plab amaliy qo'llanilishi instrumental kuchaytirgichlar, raqamli-analogli konvertorlar, analog kompyuterlar, daraja o'zgartirgichlar, filtrlar, kalibrlash zanjirlari, invertorlar, umumlashtiruvchilar, integratorlar, differensiatorlar, ayirgichlar, logarifmik kuchaytirgichlar, komparatorlar, giratorlar, osilatorlar, rektifikatorlar, kuchlanishni tok kuchiga o'zgartiruvchi konvertorlar, tok kuchini kuchlanishga o'zgartiruvchi konvertorlar va kesish asboblari.

Ulardan ba'zilar biz allaqachon ko'rib chiqdik. Bu yerda biz yana ikkita dasturni ko'rib chiqamiz: raqamli-analogli konvertor (*digital-to-analog*) va asboblarni kuchaytirgich.

5.8.1. Raqamli-analogli konvertor

Raqamli-analog konvertor (DAC) raqamli signallarni analog shaklga aylantiradi.

To‘rt bitli DAC ko‘p jihatdan amalga oshirilishi mumkin. Ikkilik sanoq tizimida o‘lchangan o‘tish yo‘lagi (*binary weighted ladder*) quyida keltirilgan.

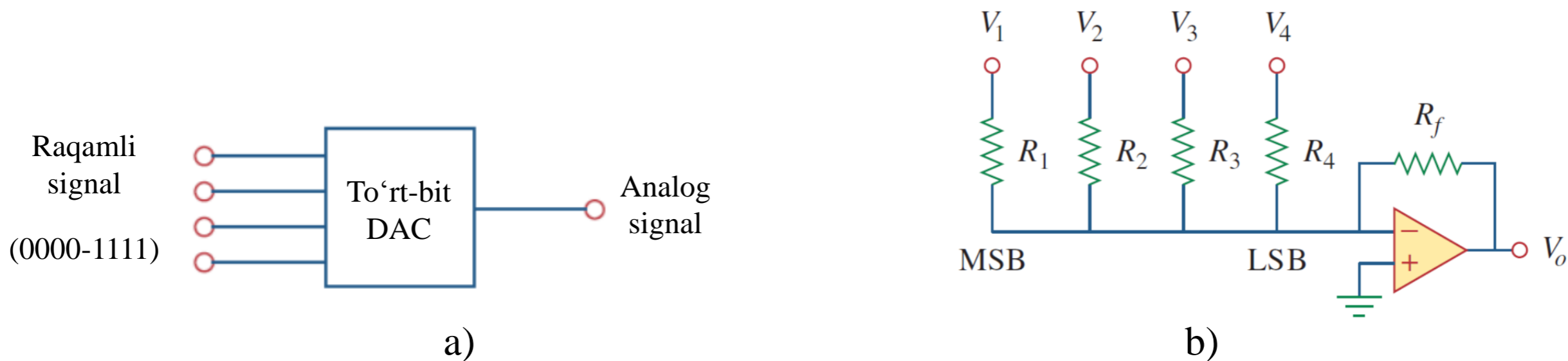

5.21-rasm. To‘rt-bit DAC:

a) blok diagrammasi; b) ikkilik sanoq tizimida o‘lchangan o‘tish yo‘lag (*binary weighted ladder*) turi.

Bitlar R_f/R_n ning kamayish tartibida bit qiymatiga ko'ra o'lchanadi. Har bir quyi bit keyingi ko'tarilishning yarm qiymatiga ega bo'ladi. Bu teskari yig'ish kuchaytirgichi hisoblanadi. Chiqish (5.15) tenglamada ko'rsatilganidek, kirishlarga ulanadi. Demak,

$$u_o = -\left(\frac{R_f}{R_1}u_1 + \frac{R_f}{R_2}u_2 + \frac{R_f}{R_3}u_3\right) \rightarrow -U_o = \frac{R_f}{R_1}U_1 + \frac{R_f}{R_2}U_2 + \frac{R_f}{R_3}U_3 + \frac{R_f}{R_4}U_4 \quad (5.23)$$

U_1 kirish eng muhim bit (*most significant bit - MSB*) deb ataladi, U_4 kirish esa eng kam ahamiyatli bit (*least significant bit - LSB*).

To'rt ikkilik kirishning har biri U_1, \dots, U_4 faqat ikkita kuchlanish darajasini qabul qilishi mumkin: 0 yoki 1 V.

Tegishli kirish va qayta aloqa o'rnatuvchi qarshilik qiymatlaridan foydalangan holda, DAC kirishlarga mutanosib bo'lgan bitta chiqishni ta'minlaydi.

Amalda, kuchlanish darajalari odatda 0 va 5 V bo'lishi mumkin.

5.8.1-masala: Quyidagi zanjirda $R_f = 10\text{ k}\Omega$, $R_1 = 10\text{ k}\Omega$, $R_2 = 20\text{ k}\Omega$,

$R_3 = 40\text{ k}\Omega$ va $R_4 = 80\text{ k}\Omega$.

Ikkilik (*binary*) kirishlar uchun analog chiqishni aniqlang [0000], [0001], [0010], ... , [1111].

Yechish:

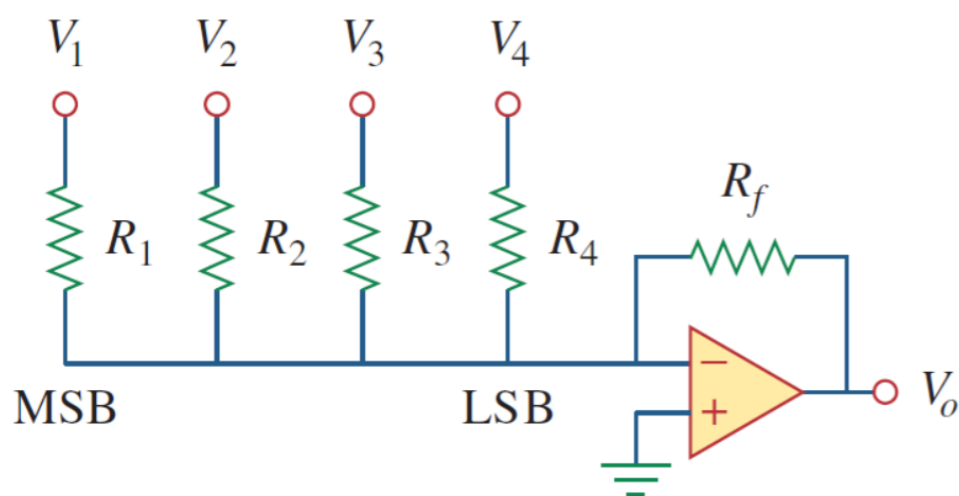

$$-U_o = \frac{R_f}{R_1} U_1 + \frac{R_f}{R_2} U_2 + \frac{R_f}{R_3} U_3 + \frac{R_f}{R_4} U_4 = U_1 + 0,5U_2 + 0,25U_3 + 0,125U_4$$

Ushbu tenglamadan foydalanib, raqamli kirish

$[U_1 U_2 U_3 U_4] = [0000]$ $-U_o = 0\text{ V}$ analog chiqishni hosil qiladi;

Demak,

$$[U_1 U_2 U_3 U_4] = [0001] \rightarrow -U_o = 0,125\text{ V ni beradi.}$$

$$[U_1 U_2 U_3 U_4] = [0010] \rightarrow -U_o = 0,125\text{ V}$$

$$[U_1 U_2 U_3 U_4] = [0011] \rightarrow -U_o = 0,25 + 0,125 = 0,375\text{ V}$$

$$[U_1 U_2 U_3 U_4] = [0100] \rightarrow -U_o = 0,5\text{ V}$$

...

$$[U_1 U_2 U_3 U_4] = [1111] \rightarrow -U_o = 1 + 0,5 + 0,25 + 0,125 = 1,875\text{ V}$$

5.8.2. Instrumental kuchaytirgichlar

Aniq o'lchash va jarayonni boshqarish uchun eng foydali va ko'p qirrali operatsion kuchaytirgich zanjirlaridan biri bu o'lchov tizimlarida keng qo'llanilganligi sababli instrumentlar kuchaytirgichi (*instrumentation amplifier - IA*) hisoblanadi.

Instrumentation amplifier with transducer bridge

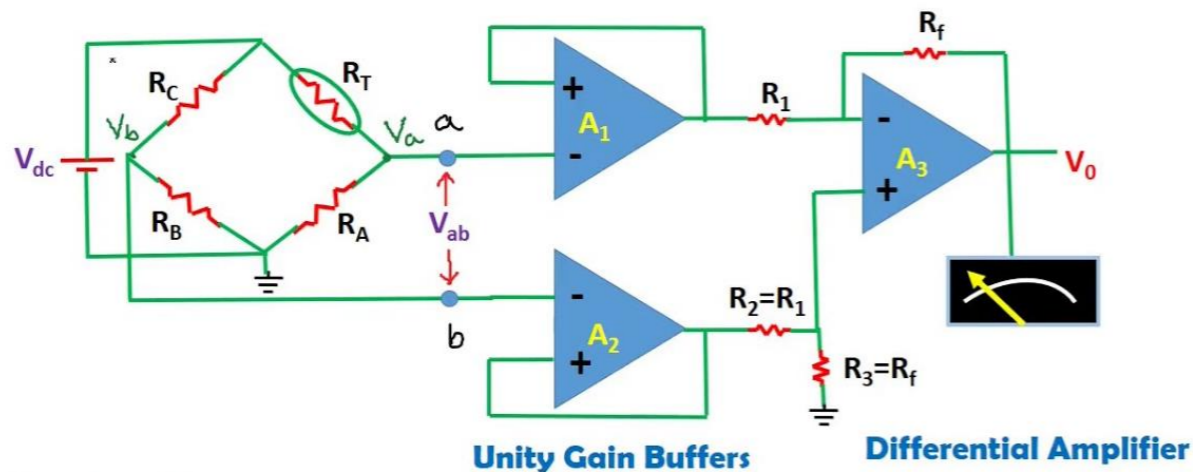

IA ning odatiy ilovalari orasida izolyatsiya kuchaytirgichlari, termojuft kuchaytirgichlari va ma'lumotlarni yig'ish tizimlari mavjud.

Instrumentlar kuchaytirgichi farq kuchaytirgichining kengaytmasi bo'lib, u kirish signallari orasidagi farqni kuchaytiradi.

Instrument kuchaytirgichi kattaroq umumiy rejimdagi kuchlanishlarga oʻrnatilgan kichik differensial signal kuchlanishlarini kuchaytiradi.

Umumiy rejimdagi kuchlanishlar teng boʻlgani uchun ular bir-birini bekor qiladi.

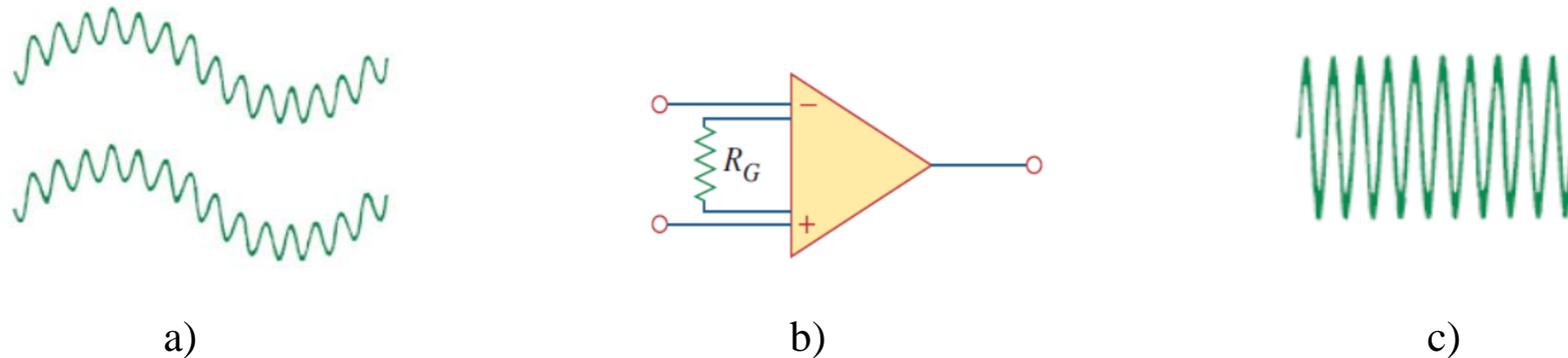

5.23-rasm.

- a) kattaroq umumiy rejim signallariga tayanadigan kichik differensial signallar;
 b) instrumental kuchaytirgich; c) kuchaytirilgan differensial signal, umumiy rejim signali yoʻq.

IA uchta asosiy xususiyatga ega:

1. Kuchlanishning kuchayishi bitta tashqi qarshilik R_G tomonidan oʻrnatiladi.
2. Ikkala kirishning kirish qarshiligi (*impedance*) juda yuqori va kattalik sozlanganligi sababli oʻzgarmaydi.
3. Chiqish u_o ular uchun umumiy kuchlanishga (umumiy rejimdagi kuchlanish) emas, balki u_1 va u_2 kirishlari orasidagi farqqa bogʻliq.

IA umumiy kuchlanishlarni rad etadi, lekin kichik signal kuchlanishlarini kuchaytiradi.

Qiymati 100Ω dan $10 \text{ k}\Omega$ gacha oʻzgarishi mumkin boʻlgan tashqi qarshilik orqali kattalik 1 dan 1000 gacha oʻzgarishi mumkin.

5.8.2-masala: 5.22-rasmda $R = 10\text{ k}\Omega$, $u_1 = 2,011\text{ V}$ va $u_2 = 2,017\text{ V}$ bo'lsin.

Agar $R_G = 500\ \Omega$ ga sozlangan bo'lsa: a) kuchlanish miqdori, b) chiqish kuchlanishini u_o .

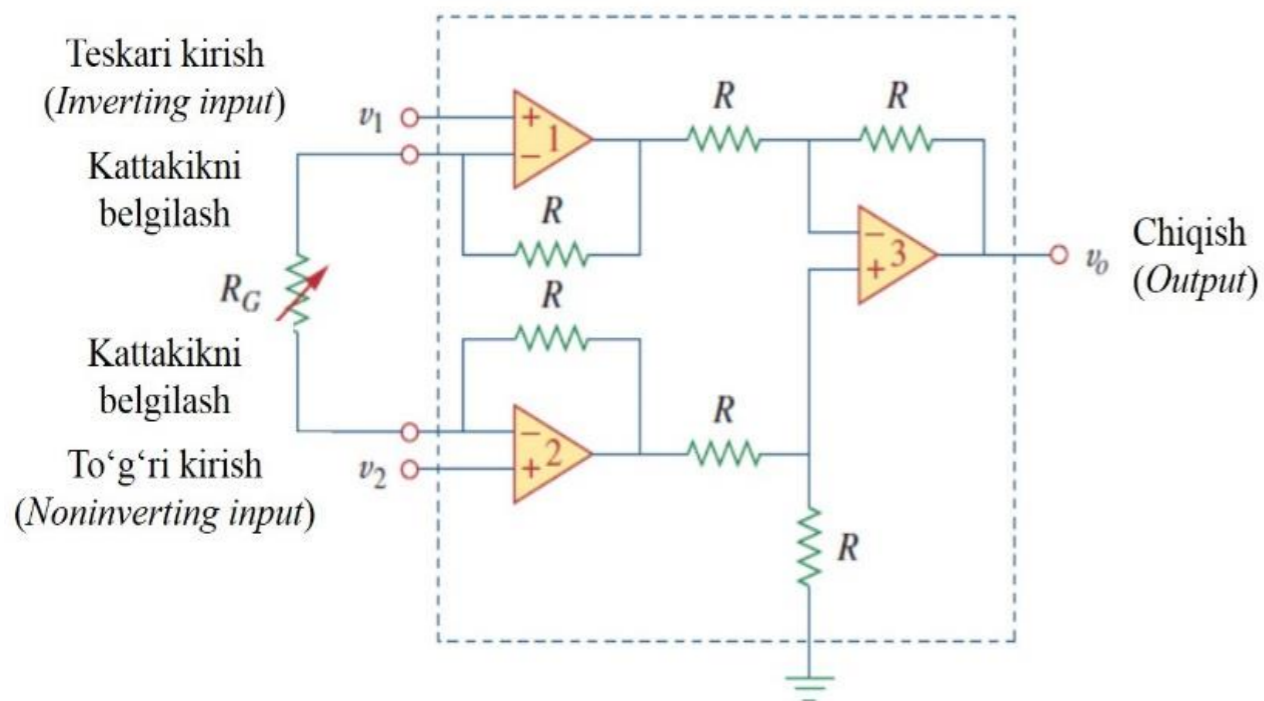

5.22-rasm.

Yechish:

a) Kuchlanish miqdori,

$$A_u = 1 + \frac{2R}{R_G} = 1 + \frac{2 \cdot 10,000}{500} = 41\text{ V}$$

b) Chiqish kuchlanishi,

$$u_o = A_u(u_2 - u_1) = 41(2,017 - 2,011) = 246\text{ mV}$$

Operatsion kuchaytirgich zanjirlarining umumlashtirilgan turlari

Operatsion kuchaytirgich zanjirlari

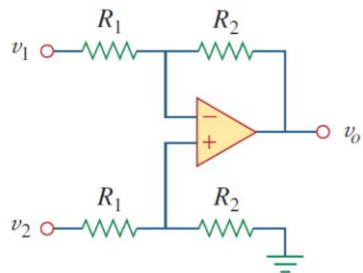
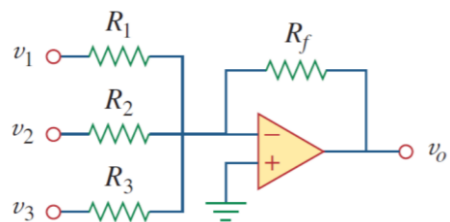
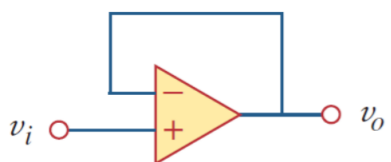
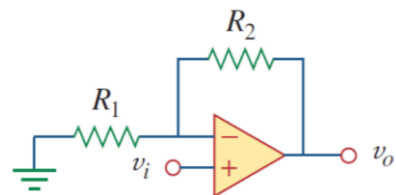
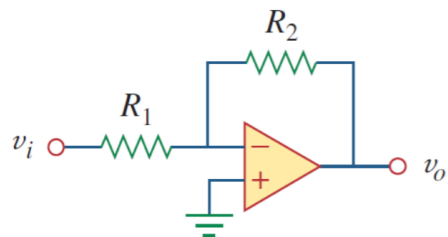

Nomlanishi /chiqish-kirish munosabati

- Teskari (*inverting*) kuchaytirgichlar

$$u_o = -\frac{R_2}{R_1} u_i$$

- Teskari bo'lmagan (*Noninverting*) kuchaytirgichlar

$$u_o = \left(1 + \frac{R_2}{R_1}\right) u_i$$

- Kuchlanish takrorlagichi (*voltage follower*)

$$u_o = u_i$$

- Umumlashtirish kuchaytirgichi (*Summing amplifier*)

$$u_o = -\left(\frac{R_f}{R_1} u_1 + \frac{R_f}{R_2} u_2 + \frac{R_f}{R_3} u_3\right)$$

- Farqlovchi kuchaytirgich (*Difference Amplifier*)

$$u_o = \frac{R_2}{R_1} (u_2 - u_1)$$

FOYDALANILGAN MANBALAR:

17. <https://i.ytimg.com/vi/KpBgf6ydplc/maxresdefault.jpg>
18. <https://i.ytimg.com/vi/POniLEqkK7c/mqdefault.jpg>
19. <https://i.ytimg.com/vi/nar2l82bJvU/maxresdefault.jpg>
20. Fundamentals of Electric Circuits, Charles K. Alexander and Matthew N. O. Sadiku / 5th edition, the McGraw-Hill Companies, Inc., -2013. – p 198-199.

TEKSHIRISH UCHUN SAVOLLAR!

5.1. Operatsion kuchaytirgichning ikkita kirish terminali quyidagicha nomlanadi:

- A) yuqori va past.
- B) ijobiy va salbiy.
- C) teskati (*inverting*) va to'g'ri (*noninverting*).
- D) differensial va differensial bo'lmagan.

5.2. Ideal operatsion kuchaytirgich uchun quyidagi fikrlardan qaysi biri to'g'ri emas?

- A) kirish terminallaridagi differensial kuchlanish nolga teng.
- B) kirish terminallaridagi tok kuchi nolga teng.
- C) chiqish terminalidagi tok kuchi nolga teng, kirish qarshiligi nolga teng.
- D) chiqish qarshiligi nolga teng.

5.3. 5.24-rasmdagi zanjir uchun chiqish kuchlanishi u_o qanday qiymatga teng?

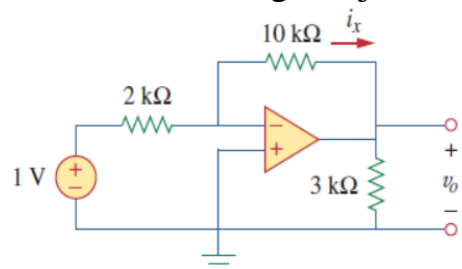

5.24-rasm.

- A) -6 V.
- B) -5 V
- C) -1,2 V
- D) -0,2 V.

5.4. 5.24-rasmdagi zanjir uchun tok kuchi i_x qanday qiymatga teng?

- A) 0,6 mA.
- B) 0,5 mA.
- C) 0,2 mA.
- D) 1/12 mA.

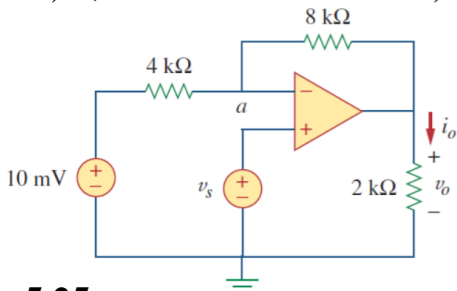

5.25-rasm.

5.5. 5.25-rasmdagi zanjir uchun $u_s = 0$ bo'lsa, tok kuchi i_o qanday qiymatga teng?

- A) -10 mA.
- B) -2,5 mA.
- C) 10/12 mA.
- D) 10/14 mA.

5.6. 5.25-rasmdagi zanjir uchun $u_s = 8 mV$ bo'lsa, chiqish kuchlanishi u_o qanday qiymatga teng?

- A) -44 mV.
- B) -8 mV.
- C) 4 mV.
- D) 7 mV.

5.7. 5.25-rasmdagi zanjir uchun $u_s = 8 mV$ bo'lsa, kirish kuchlanishi u_a qanday qiymatga teng?

- A) -8 mV.
- B) 0 mV.
- C) 10/3 mV.
- D) 8 mV.

5.8. 5.26-rasmdagi zanjirda 4 kΩ rezistor tomonidan sarflanayotgan quvvat qanday qiymatga teng?

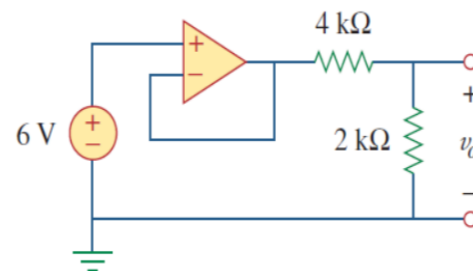

5.26-rasm.

- A) 9 mW.
- B) 4 mW.
- C) 2 mW.
- D) 1 mW.

5.9. Ushbu kuchaytirgichlardan qaysi biri raqamli-analogli konvertorda ishlatiladi?

- A) to'g'ri (*noninverter*).
- B) kuchlanish takrorlagichi (*voltage follower*).
- C) umumlashtiruvchi (*summer*).
- D) farqlovchi kuchaytirgich (*difference amplifier*).

5.10. Farq kuchaytirgichlari quyidagi hollarda qo'llaniladi (*iltimos, amaldagilarning barchasini tekshiring*):

- A) asboblari kuchaytirgichlari, kuchaytirgichlarni ayirish.
- B) kuchlanish takrorlagichlari.
- C) kuchlanish regulyatorlari.
- D) buferlar, jamlovchi kuchaytirgichlar.



*E'TIBORINGIZ
UCHUN
RAHMAT!!!*