

6-Mavzu: Kondensator va induktiv g'altak.

(Lecture-6: Capacitors and Inductors)

6-Mavzuning 3-qismi

(Part 3 of the Lecture-6)

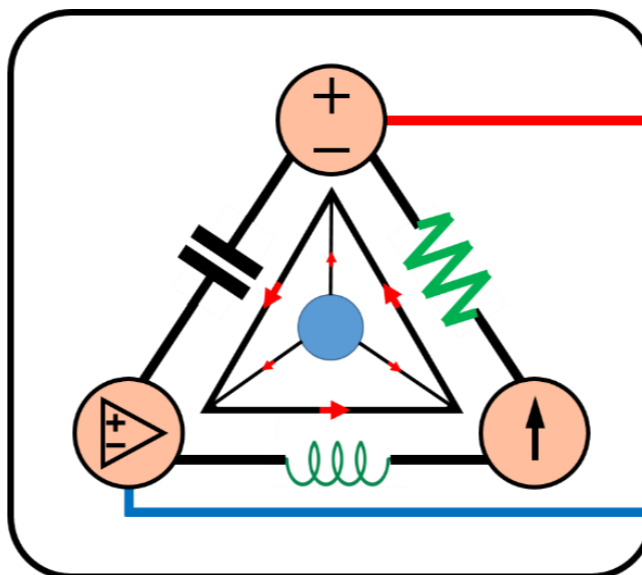

Lecturer: Ph.D., Yusupov Sarvarbek

*Toshkent Kimyo Xalqaro Universiteti
"Mashinasozlik texnologiyasi" kafedrası
Toshkent shahri, Usmon Nosir, 156-uy.*

6-Mavzu: Kondensator va induktiv g'altak.

(Lecture-6: Capacitors and Inductors)

O'quv rejasi:

- 6.1. Kondensatorlar.
- 6.2. Ketma-ket va parallel ulangan kondensatorlar.
- 6.3. Induktiv g'altaklar (Induktorlar).
- 6.4. Ketma-ket va parallel ulangan induktorlar.
- 6.5. Kondensator va induktiv g'altaklarda tok kuchi va kuchlanishni bo'linish qoidasi.**
- 6.6. Kondensator va induktiv g'altaklarning qo'llanilishi.**

6.5. Kondensator va induktiv g'altalarda tok kuchi va kuchlanishni bo'linish qoidasi.

TOK KUCHINI BO'LINISH QOIDASI

Elektr zanjirida har ikkala elementlar parallel ulanadi.

KONDENSATOR

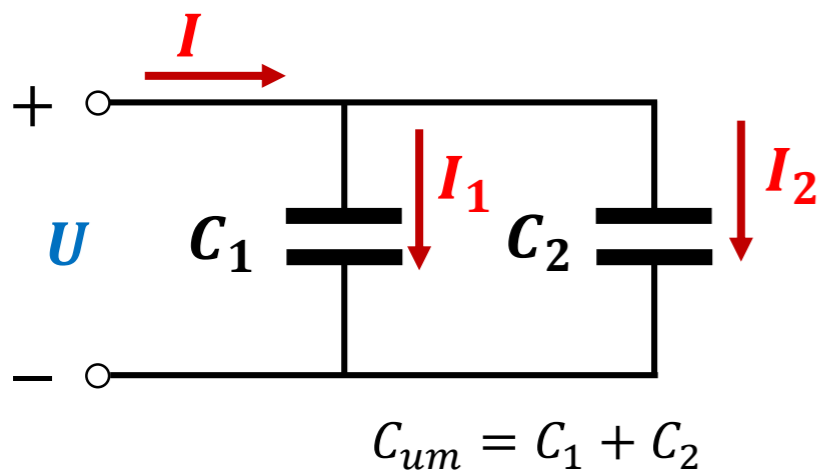

$$I = C_{um} \frac{du}{dt} \rightarrow \frac{du}{dt} = \frac{I}{C_1 + C_2}$$

$$I_1 = C_1 \frac{du}{dt} = \frac{I}{C_1 + C_2} C_1; \quad I_2 = C_2 \frac{du}{dt} = \frac{I}{C_1 + C_2} C_2;$$

INDUKTIV G'ALTAK

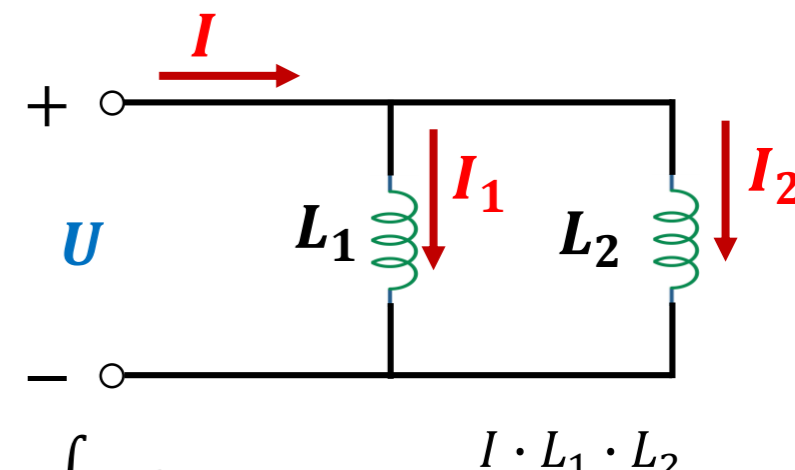

$$L_{um} = \frac{L_1 \cdot L_2}{L_1 + L_2}$$

$$I = \frac{1}{L_{um}} \int u dt$$

$$U = L_{um} \frac{di}{dt}$$

$$I_1 = \frac{1}{L_1} \int u dt = \frac{1}{L_1} \cdot \frac{I \cdot L_1 \cdot L_2}{L_1 + L_2} = \frac{I}{L_1 + L_2} L_2;$$

$$I_2 = \frac{1}{L_2} \int u dt = \frac{1}{L_2} \cdot \frac{I \cdot L_1 \cdot L_2}{L_1 + L_2} = \frac{I}{L_1 + L_2} L_1;$$

KUCHLANISHINI BO‘LINISH QOIDASI

KONDENSATOR

Elektr zanjirida har ikkala elementlar ketma-ket ulanadi.

INDUKTIV G‘ALTAK

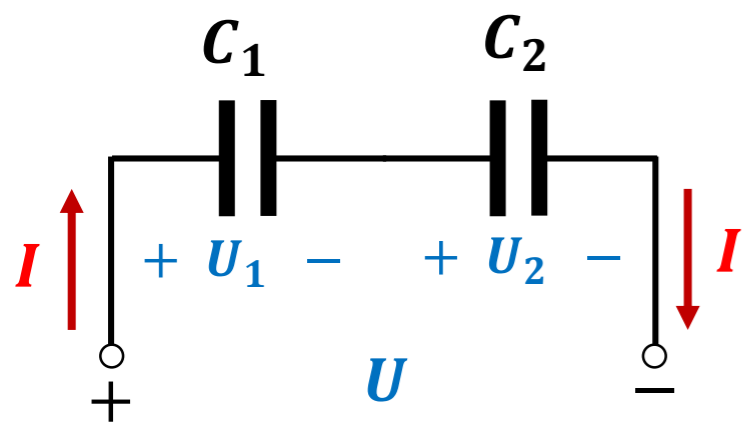

$$\frac{1}{C_{um}} = \frac{1}{C_1} + \frac{1}{C_2}$$

$$C_{um} = \frac{C_1 \cdot C_2}{C_1 + C_2}$$

$$Q = C_{um} \cdot U = \frac{C_1 \cdot C_2}{C_1 + C_2} \cdot U$$

$$U_1 = \frac{Q}{C_1} = \frac{C_1 \cdot C_2}{C_1 + C_2} \cdot U \cdot \frac{1}{C_1} = \frac{U}{C_1 + C_2} \cdot C_2;$$

$$U_2 = \frac{Q}{C_2} = \frac{C_1 \cdot C_2}{C_1 + C_2} \cdot U \cdot \frac{1}{C_2} = \frac{U}{C_1 + C_2} \cdot C_1;$$

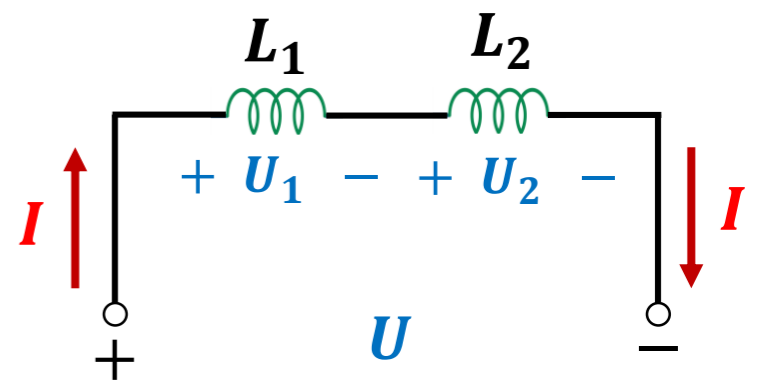

$$U = L_{um} \frac{di}{dt} \rightarrow \frac{di}{dt} = \frac{U}{L_1 + L_2}$$

$$U_1 = L_1 \frac{di}{dt} = \frac{U}{L_1 + L_2} \cdot L_1$$

$$U_2 = L_2 \frac{di}{dt} = \frac{U}{L_1 + L_2} \cdot L_2$$

6.6. Kondensator va induktiv g'altaklarning qo'llanilishi.



Photo source: [17] - <https://cdn.sparkfun.com/assets/d/8/a/b/5/51dc69f2ce395fab63000000.png>

Rezistorlar va kondensatorlar kabi elektron elementlar diskret shaklda yoki integrallashgan zanjir (*IC-integrated-circuit*) shaklida xarid qilinadi.

Kondensatorlar va rezistorlardan farqli o'laroq, induktorlarni IC bo'limlarini ishlab chiqarish qiyin.

Shuning uchun induktorlar (*g'altaklar*) diskret shaklda bo'ladi va ular ko'p hajmli va qimmat bo'ladi.

Induktorlar kondensatorlar va rezistorlar kabi ko'p qirrali emas va ularni qo'llanilishi cheklangan.

Lekin, induktorlarning amaliy o‘rnini bosadigan bir nechta muqobillar mavjud.

Ular muntazam ravishda relelar, sensorli qurilmalar, telefon zanjirlari, radio va televideniya qabul qiluvchilar, quvvat manbalari, elektr motorlar, mikrofonlar, ovoz kuchaytirgichlarda va boshqa qurilmalarda ishlatiladi.



Photo source: [18] -
https://cdn.shopify.com/s/files/1/0014/4313/5560/products/AD317-2_535x.jpg?v=1644512231

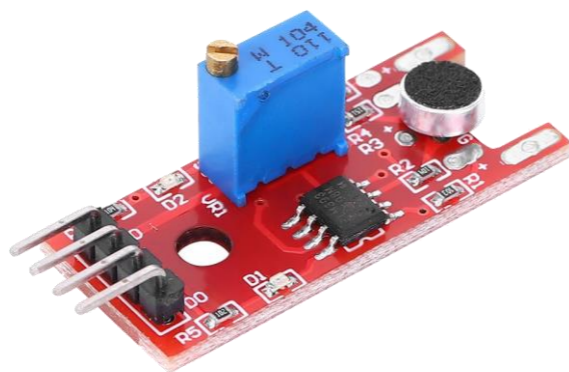

Photo source: [19] -
https://ae01.alicdn.com/kf/H066dac0f6d2c4793b063435877f97dbfr/5Pcs-Sound-Sensor-Module-Ultra-Small-Professional-Microphone-Sensor-Detection-Module-Amplifier-IC-KY-038.jpg_Q90.jpg.webp



Photo source: [20] -
<https://5.imimg.com/data5/FR/PA/EB/SELLER-3801422/speaker-driver-500x500.jpg>



Photo source: [21] -
<https://i5.walmartimages.com/asr/d0646b9a-ce01-4b88-8670-eb57522d95bb.131a1c69c9b0dd5cec2ca3f29217234c.jpeg>

Kondensatorlar va induktorlar quyidagi uchta muhim xususiyatga ega, bu ularni elektr zanjirlarida juda foydali qiladi:

1. Energiyani saqlash qobiliyati ularni vaqtinchalik kuchlanish yoki tok kuchi manbalari sifatida foydalidir. Ya'ni ular qisqa vaqt ichida katta miqdorda tok kuchi yoki kuchlanish hosil qilish uchun ishlatilishi mumkin.

2. Kondensatorlar kuchlanishning keskin o'zgarishiga qarshi. Induktorlar esa tok kuchining keskin o'zgarishiga qarshi. Bu xususiyat induktorlarni uchqun yoki yoyni bostirish va pulsatsiyalanuvchi o'zgarimas kuchlanishni nisbatan barqaror o'zgarimas kuchlanishga aylantirish uchun foydalidir.

3. Kondensatorlar va induktorlar chastotaga sezgir. Bu xususiyat ularni chastotali diskriminatsiya uchun foydali qiladi.

Birinchi ikkita xususiyat o'zgarmas tok zanjirlarida qo'llaniladi, uchinchi esa o'zgaruvchan tok zanjirlarida qo'llaniladi.

Kondensatorlar va operatsion kuchaytirgichlarni o'z ichiga olgan uchta tadbig'ini ko'rib chiqamiz. Bular: kuchaytiruvchi (*integrator*), farqlovchi (*differensiator*) va analog kompyuter.

6.6.1. Kuchaytiruvch.

Energiyani saqlash elementlaridan foydalanadigan muhim operatsion kuchaytirgich zanjirlari integratorlar va differensiatorlarni o'z ichiga oladi.

Bu operatsion kuchaytirgich zanjirlari ko'pincha rezistorlar va kondensatorlardan iborat bo'ladi.

Induktorlar katta hajmda bo'lishi uchun uning tannarhi qimmatlashishiga olib keladi

Operatsion kuchaytirgich integratori ko‘plab tadbiquqa ega, u analog kompyuterlarda qo‘llaniladi.

Integrator - bu kirish signalining integraliga proporsional bo‘lgan operatsion kuchaytirgich zanjiridir.

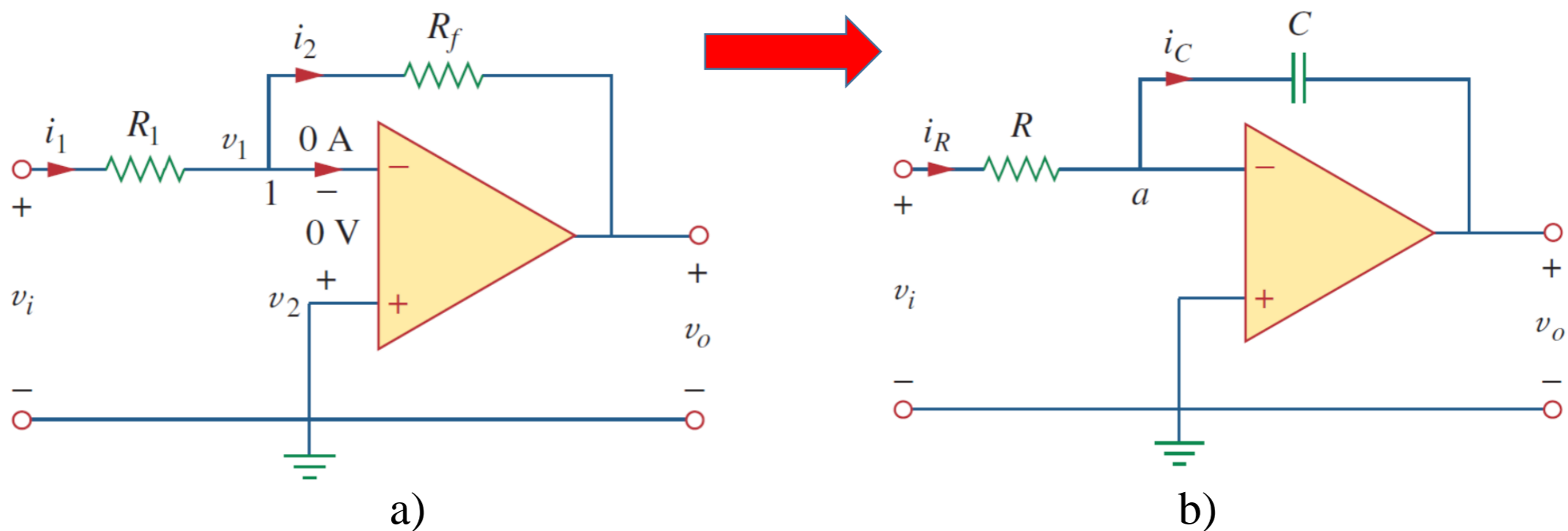

6.23-rasm.

a) teskari kuchaytirgichda qayta aloqa rezistori; b) qayta aloqa condensatori bilan almashtirilganda integratori hosil qilinishi.

Integralning matematik ko‘rinishini shu tarzda olishimiz mumkin.

a tuguni bo‘yicha tahlil qilsak,

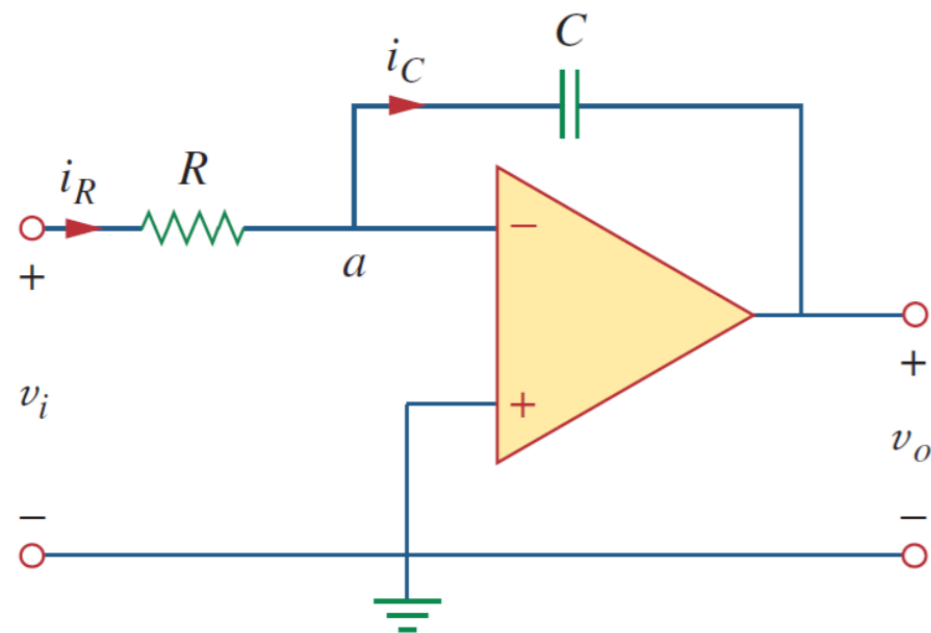

$$i_R = i_C \quad (6.34)$$

$$i_R = \frac{u_i}{R}, \quad i_C = -C \frac{du_o}{dt},$$

$$\frac{u_i}{R} = -C \frac{du_o}{dt} \quad (6.35.1)$$

$$du_o = -\frac{1}{RC} u_i dt \quad (6.35.2)$$

$$u_o(t) - u_o(0) = -\frac{1}{RC} \int_0^t u_i(\tau) d\tau \quad (6.36)$$

$u_o(0) = 0$ ni ta'minlash uchun signalni qo'llashdan oldin har doim integratorning kondensatorini zaryadsizlantirish kerak. Faraz qilsak $u_o(0) = 0$,

$$u_o = -\frac{1}{RC} \int_0^t u_i(\tau) d\tau \quad (6.37)$$

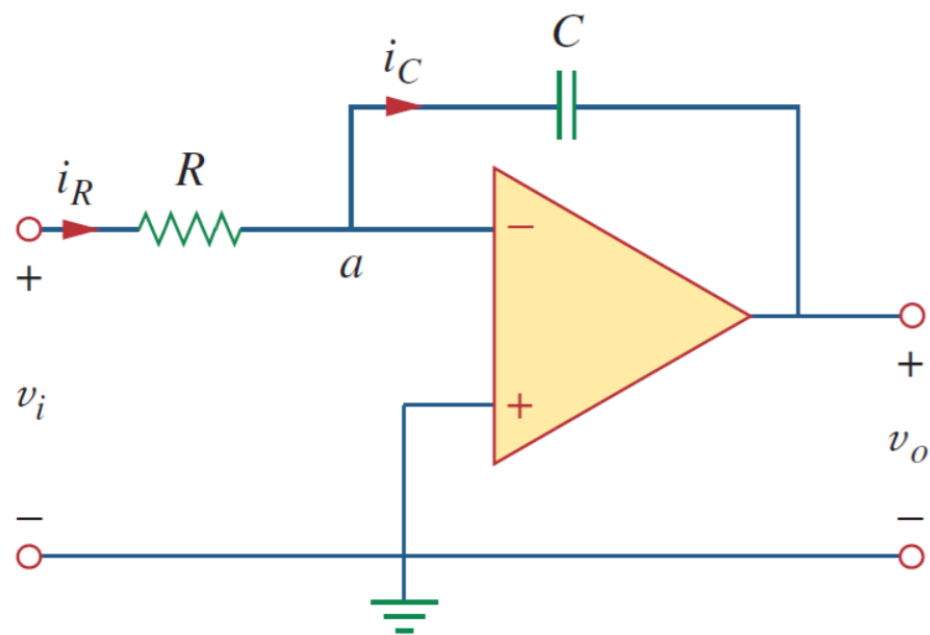

Bu zanjir kirishning integraliga proporsional chiqish kuchlanishini ta'minlaganligini ko'rsatadi.

Amalda, operatsion kuchaytirgich integratori doimiy tokni kamaytirish va to'yinganlikni oldini olish uchun qayta aloqa qarshiligini talab qiladi.

6.6.1-masala: Agar $u_1 = 10\cos 2t \text{ mV}$ va $u_2 = 0,5t \text{ mV}$

6.24-rasmdagi operatsion kuchaytirgich zanjiridagi u_o toping.

Kondensatordagi kuchlanish dastlab nolga teng deb hisoblang.

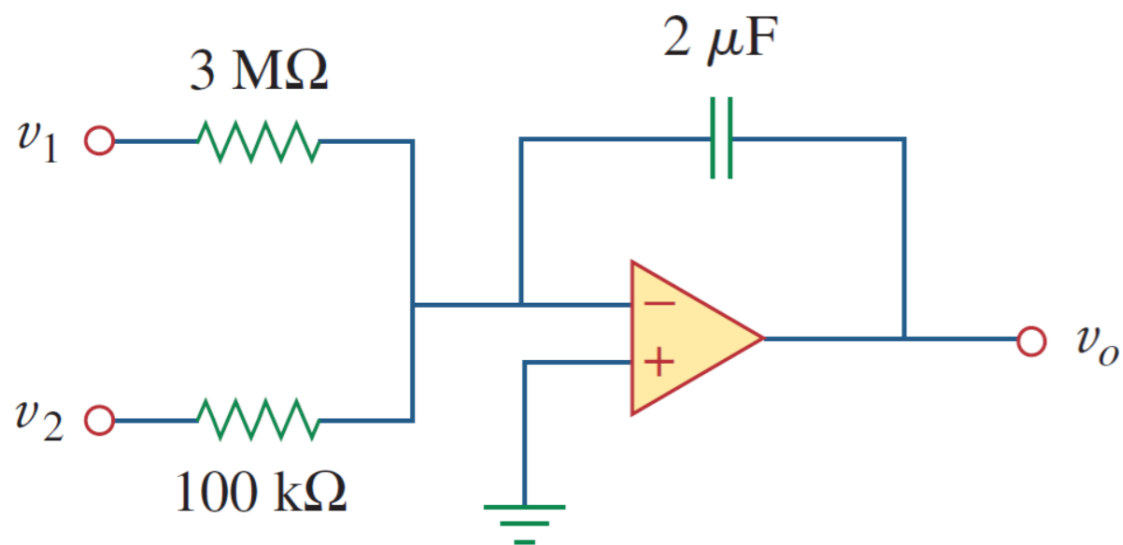

Bu umumlashtiruvchi integrator hisoblanadi.

6.24-rasm.

$$\begin{aligned}
 u_o &= -\frac{1}{R_1 C} \int u_1 dt - \frac{1}{R_2 C} \int u_2 dt = \\
 &= -\frac{1}{3 \cdot 10^6 \cdot 3 \cdot 10^{-6}} \int_0^t 10 \cos(2\tau) d\tau - \frac{1}{100 \cdot 10^3 \cdot 2 \cdot 10^{-6}} \int_0^t 0,5\tau d\tau = \\
 &= -\frac{1}{6} \cdot \frac{10}{2} \sin 2t - \frac{1}{0,2} \cdot \frac{0,5t^2}{2} = \\
 &= -0,833 \sin 2t - 1,25t^2 \text{ mV}
 \end{aligned}$$

6.6.2. Farqlovchi (differentiator).

Differentiator - bu kirish signalining o'zgarish tezligiga proporsional bo'lgan operatsion kuchaytirgich zanjiridir.

6.23-rasm, *a* da agar kirish qarshiligi kondensator bilan almashtirilsa, natijada olingan zanjir 6.24-rasmda ko'rsatilgan farqlovchi hisoblanadi.

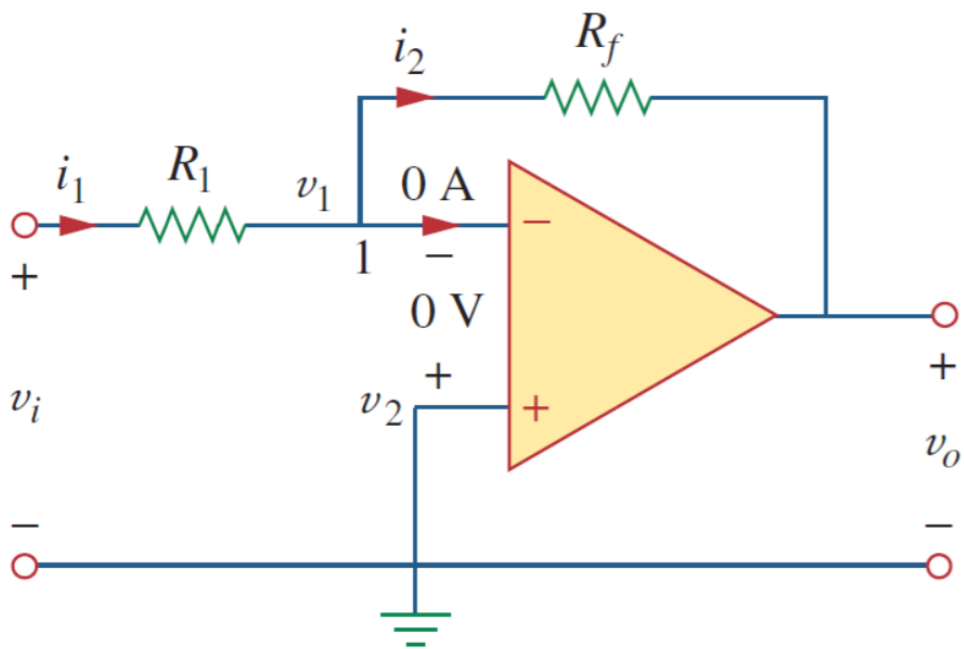

KCL ni *a* tugun uchun qo'llaymiz, $i_R = i_C$ (6.38)

$$i_R = -\frac{u_o}{R}, \quad i_C = C \frac{du_i}{dt}$$

$$u_o(t) - u_o(0) = -\frac{1}{RC} \int_0^t u_i(\tau) d\tau$$

$$u_o = -RC \frac{du_i}{dt} \quad (6.39)$$

Chiqish kirishning hosilasi ekanligini ko'rsatadi.

6.24-rasm. Farqlovchi operatsion kuchaytirgich.

6.6.3. Analog kompyuter.

Operatsion kuchaytirgichlar dastlab elektron analog kompyuterlar uchun ishlab chiqilgan.

Analog kompyuterlar mexanik yoki elektr tizimlarning matematik modellarini yechish uchun dasturlashtirilishi mumkin.

Bu modellar odatda differensial tenglamalar bilan ifodalanadi.

Analog kompyuter yordamida oddiy differensial tenglamalarni yechish uchun uchta turdagi operatsion kuchaytirgich zanjirlarini kaskadlash kerak: integrator zanjirlari, umumlashtirish (*yig'ish*) kuchaytirgichlari va salbiy/ijobiy masshtablash uchun teskari va teskari bo'lmagan kuchaytirgichlar.

- integrator zanjirlari;
- umumlashtirish (*yig'ish*) kuchaytirgichlari;
- salbiy/ijobiy masshtablash uchun teskari va teskari bo'lmagan kuchaytirgichlar.

Har qanday differensial tenglama integratorlar, invertorlar va teskari yigʻindilarini oʻz ichiga olgan analog kompyuter tomonidan simulyatsiya qilinishi mumkin.

Ammo rezistor va kondensator qiymatlarini tanlashda, qaror qabul qilish vaqt oraligʻida operatsion kuchaytirgichlarning toʻyinganligini taʼminlash uchun ehtiyot boʻlish kerak.

Vakuum quvurlari boʻlgan analog kompyuterlar 1950 va 1960 yillarda ishlab chiqilgan.

Ularning oʻrnini zamonaviy raqamli kompyuterlar egalladi.

Biroq, biz hali ham ikkita sababga ko‘ra analog kompyuterlarni o‘rganamiz:

Birinchidan, o‘rnatilgan operatsion kuchaytirgichlarning mavjudligi analog kompyuterlarni oson va arzon narhlarda ishlab chiqarish imkonini beradi;

Ikkinchidan, analog kompyuterlarni tushinish raqamli kompyuterlarni tushunishga yordam beradi (6.27-rasm).



a)



b)

6.27-rasm.

a) analog kompyuter; b) digital kompyuter.

Photo source: [22] - <https://cdnb.artstation.com/p/assets/images/images/024/887/819/large/bethany-fox-akat-render5.jpg?1583860527>

Photo source: [23] - <https://studiousguy.com/wp-content/uploads/2020/10/Digital-Computers.png>

FOYDALANILGAN MANBALAR:

17. <https://cdn.sparkfun.com/assets/d/8/a/b/5/51dc69f2ce395fab63000000.png>
18. https://cdn.shopify.com/s/files/1/0014/4313/5560/products/AD317-2_535x.jpg?v=1644512231
19. https://ae01.alicdn.com/kf/H066dac0f6d2c4793b063435877f97dbfr/5Pcs-Sound-Sensor-Module-Ultra-Small-Professional-Microphone-Sensor-Detection-Module-Amplifier-IC-KY-038.jpg_Q90.jpg_.webp
20. <https://5.imimg.com/data5/FR/PA/EB/SELLER-3801422/speaker-driver-500x500.jpg>
21. <https://i5.walmartimages.com/asr/d0646b9a-ce01-4b88-8670-eb57522d95bb.131a1c69c9b0dd5cec2ca3f29217234c.jpeg>
22. <https://cdnb.artstation.com/p/assets/images/images/024/887/819/large/bethany-fox-akat-render5.jpg?1583860527>
23. <https://studiousguy.com/wp-content/uploads/2020/10/Digital-Computers.png>

TEKSHIRISH UCHUN SAVOLLAR!

6.1. 5 F kondensator 120 V manba orqali ulanganda qanday zaryad bo'ladi?

- A) 600 C. B) 300 C. C) 24 C. D) 12 C.

6.2. Sig'im nimada o'lchanadi?

- A) kulonlarda. B) joullarda. C) genrilarda. D) faradlarda.

6.3. Kondensatorning umumiy zaryadi ikki baravar ko'payganda, energiya saqlanadimi?

- A) o'zgarishsiz qoladi. B) yarmiga qisqartiriladi.
C) ikki baravar ko'payadi. D) to'rt barobar ko'payadi.

6.4. 6.28-rasmdagi kuchlanish to'lqin shakli haqiqiy kondensator bilan bog'lanishi mumkinmi?

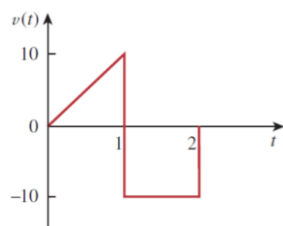

6.28-rasm.

- A) ha.
B) yo'q.

6.5. 4 mF kondensator bilan parallel ravishda ikkita 40 mF ketma-ket ulangan kondensatorning umumiy sig'imini toping?

- A) 3,8 mF. B) 5 mF. C) 24 mF. D) 44 mF.

6.6. 6.29-rasmda, agar $i = \cos 4t$ va $u = \sin 4t$ bo'lsa, u qanday element?

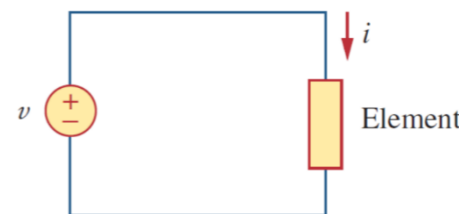

6.29-rasm.

- A) rezistor.
B) kondensator.
C) induktor.
D) operatsion kuchaytirgich.

6.7. 5 H induktorning tok kuchi 0,2 soniyada 3 A ga o'zgartiradi. Induktorning terminallarida hosil bo'ladigan kuchlanishni toping.

- A) 75 V. B) 8,888 V. C) 3 V. D) 1,2 V.

6.8. Agar 10 mH induktordan o'tadigan tok noldan 2 A ga oshsa, induktorda qancha energiya saqlanadi?

- A) 40 mH. B) 20 mH. C) 10 mH. D) 5 mH.

6.9. Parallel bo'lgan induktorlar parallel ravishda rezistorlar kabi birlashtirilishi mumkinmi?

- A) to'g'ri. B) noto'g'ri.

6.10. 6.30-rasmdagi zanjir uchun kuchlanishni taqsimlovchi formulasi qaysi?

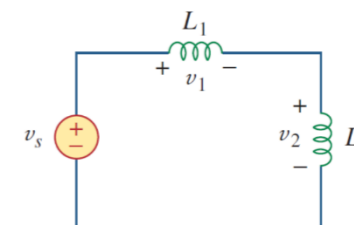

6.30-rasm.

- A) $u_1 = \frac{L_1+L_2}{L_1} u_s$.
B) $u_1 = \frac{L_1+L_2}{L_2} u_s$.
C) $u_1 = \frac{L_2}{L_1+L_2} u_s$.
D) $u_1 = \frac{L_1}{L_1+L_2} u_s$.



*E'TIBORINGIZ
UCHUN
RAHMAT!!!*