

9-Mavzu: O‘zgaruvchan tok zanjiri. Sinusoidlar va fazalar (*davomi*).

(9th Topic: AC Circuit. Sinusoids and Phasors)

9-Mavzuning 3-qismi

(3rd part of the 9th Topic)

*12-hafta uchun
For the 12th week*

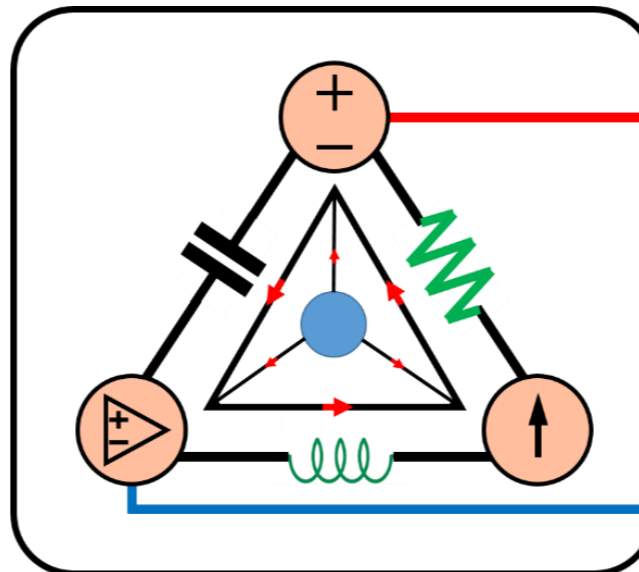

Lecturer: Ph.D., Yusupov Sarvarbek

*Toshkent Kimyo Xalqaro Universiteti
“Mashinasozlik texnologiyasi” kafedrası
Toshkent shahri, Usmon Nosir, 156-uy.*



9-Mavzu: O'zgaruvchan tok zanjiri. Sinusoidlar va fazalar (*davomi*).

(9th Topic: AC Circuit. Sinusoids and Phasors.)

O'quv rejası:

9.5. Qarshilik va o'tkazuvchanlik (impidance and admittance).

9.6. Chastotalar sohasida Kirxgof qonunlari.

9.9. Qarshilik kombinatsiyalari.

9.8. Qo'llanilishi.

9.5. Qarshilik va o'tkazuvchanlik (*impidance and admittance*).

Oldingi bo'limda biz uchta passiv element uchun kuchlanish-tok kuchi munosabatlarini oldik,

$$U = RI, \quad U = j\omega LI, \quad U = \frac{I}{j\omega C} \quad (9.38)$$

Ushbu tenglamalar faza kuchlanishining faza tok kuchiga nisbati sifatida yozilishi mumkin.

$$\frac{U}{I} = R, \quad \frac{U}{I} = j\omega L, \quad \frac{U}{I} = \frac{1}{j\omega C} \quad (9.39)$$

Bu uchta ifodadan biz Om qonunini har qanday turdagi element uchun faza shaklida olamiz.

$$Z = \frac{U}{I} \quad \text{yoki,} \quad U = ZI \quad (9.40)$$

bu yerda: Z – qarshilik (impidens) deb nomlanuvchi chastotaga bog'liq miqdor.

O‘zgaruvchan tok zanjirning impedansi **Z** kuchlanish **U** ning fazasini tok kuchi **I** fazasiga nisbatini bildiradi va Om (Ω) bilan o‘lchanadi.

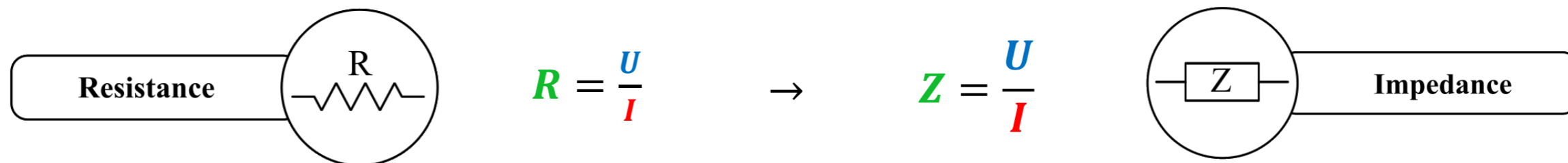

Impidens zanjirning sinusoidal tok oqimiga qarshiligini ifodalaydi.

Impidens ikki fazaning nisbati bo‘lsa-da, u faza emas, chunki u sinusoidal o‘zgaruvchan miqdorga mos kelmaydi.

Rezistorlar, induktorlar va kondensatorlarning impedanslarini (9.39) tenglamadan osongina topish mumkin.

Photo source: [11] - https://blogger.googleusercontent.com/img/b/R29vZ2xl/AVvXsEisX89LUX0SaruLITujBF9tALzagqfyDJsEOzpROa53G136gCtxnasB_6_JwXg39Bf7phQzpKxJNWvY5yLwO8Dm5F-QjI4pLcWmmir6_qloHI1baqv_kYIVgBgPyu5GxkdYRMPthqMPPrVnBGuehQOelBnAFz3XelQr2n2TSzSPLmCjv6_e9V-U65YLv/w320-h240/resistance%20versus%20impedance.png

Passiv elementlar impedanslarini umumlashtirilgan jadvali.

9.3-jadval

Passiv elementlarning qarshilik va o'tkazuvchanlari

Passiv elementlar	Qarshilik (Impedance)	O'tkazuvchan (Admittance)
Burchak chastotasi – ω	Z	Y
R	$Z = R$	$Y = \frac{1}{Z}$
L	$Z = j\omega L$	$Y = \frac{1}{j\omega L}$
C	$Z = \frac{1}{j\omega C}$	$Y = j\omega C$

Jadvaldan biz $Z_L = j\omega L$ va $Z_C = -\frac{j}{\omega C}$ ekanligini ko‘ramiz.

Burchak chastotasining ikkita ekstremal holatini ko‘rib chiqamiz.

Agar $\omega = 0$ bo‘lsa, (ya‘ni, o‘zgarmas tok uchun), induktor - $Z_L = 0$ qisqa tutashuv va kondensator - $Z_C \rightarrow \infty$ ochiq zanjir kabi ishlaydi.

Agar $\omega \rightarrow \infty$ bo‘lsa, (ya‘ni, yuqori chastotalar uchun), induktor - $Z_L \rightarrow \infty$ ochiq zanjir va kondensator - $Z_C = 0$ qisqa tutashuv kabi ishlaydi.



9.14-rasm. DC sharoitida va yuqori chastotalarda ekvivalent zanjirlar.

Kompleks miqdor sifatida impedans to'rtburchaklar shaklida ifodalanishi mumkin.

$$Z = R + jX \quad (9.41)$$

bu yerda: $R = \text{Re}Z$ qarshilik (*resistance*) va $X = \text{Im}Z$ reaktiv qarshilik (*reactance*).

X reaktiv qarshiligi ijobiy yoki salbiy bo'lishi mumkin.

Impedance



Photo source: [12] - https://solderingmind.com/?attachment_id=1530

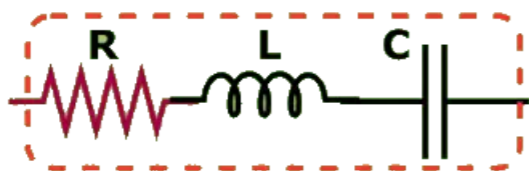

$$Z = R + j(X_L - X_C)$$

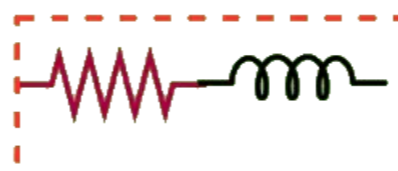

$$Z = R + jX_L$$

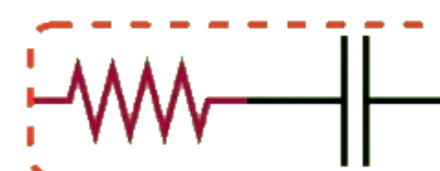

$$Z = R - jX_C$$

X - musbat bo'lganda impedans induktivli

X - manfiy bo'lsa sig'imli

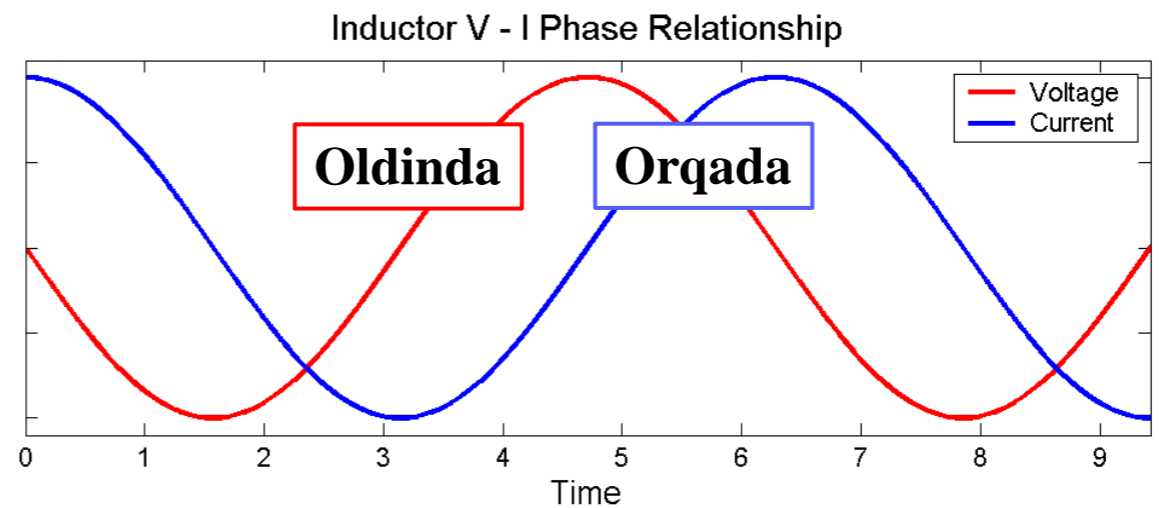
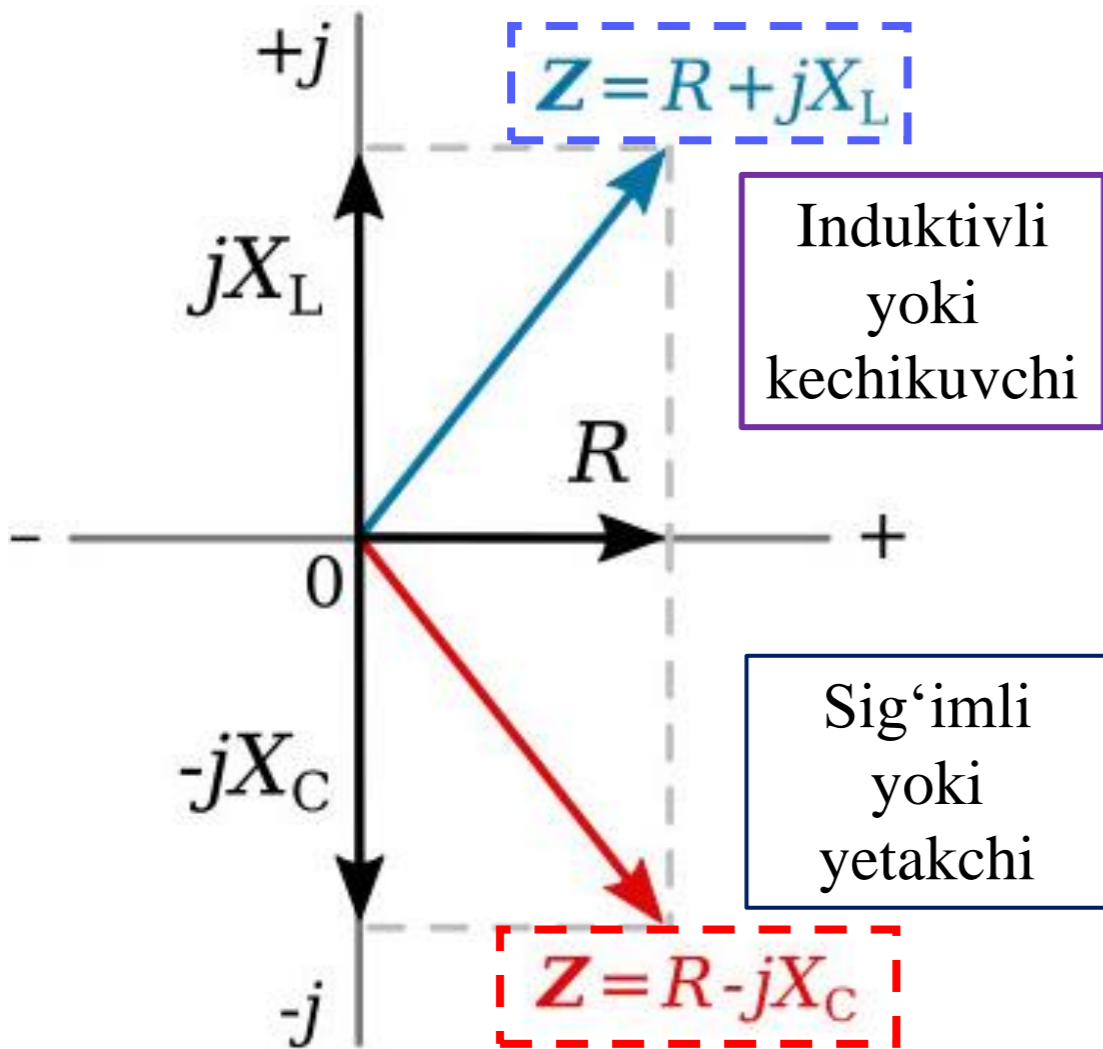

**Tok kuchi
kuchlanishdan
kechikadi**

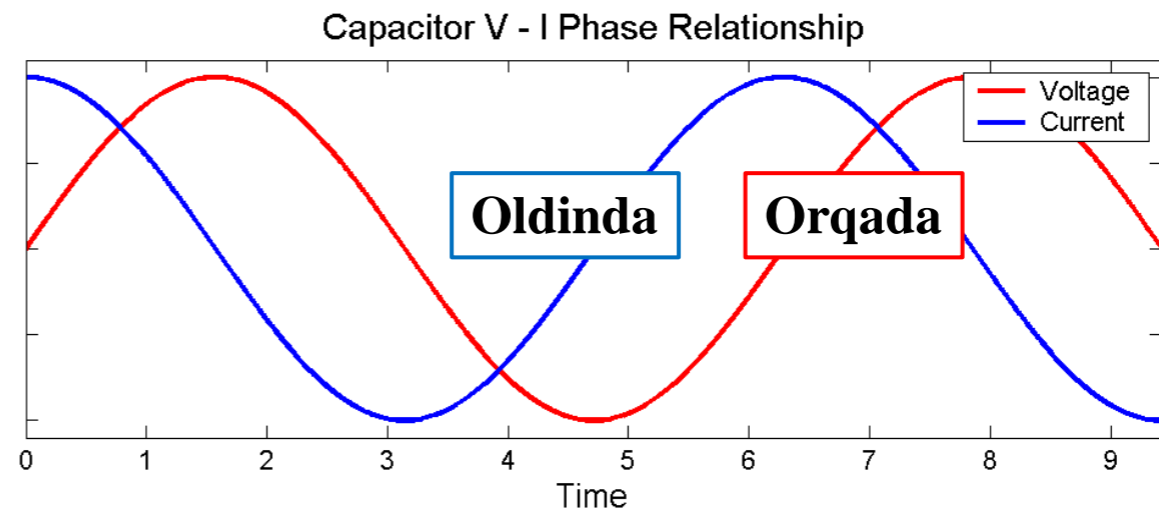

**Tok kuchi
kuchlanishdan
oldinda**

Photo source: [14] - <https://ecstudiosystems.com/discover/textbooks/basic-electronics/ac-circuits/images/impedance-on-complex-plane.jpg>

Photo source: [15] - <https://i.stack.imgur.com/pvJPd.png>

Impidens, qarshilik va reaktiv qarshilik Omlarda oʻlchanadi. Impidens qutbli shaklda ham ifodalanishi mumkin.

$$\mathbf{Z} = |\mathbf{Z}| \angle \theta \quad (9.42)$$

$$\mathbf{Z} = \mathbf{R} + j\mathbf{X} \rightarrow \mathbf{Z} = |\mathbf{Z}| \angle \theta \rightarrow \mathbf{Z} = \mathbf{R} + j\mathbf{X} = |\mathbf{Z}| \angle \theta \quad (9.43)$$

$$|\mathbf{Z}| = \sqrt{\mathbf{R}^2 + \mathbf{X}^2}$$

$$\theta = \tan^{-1} \frac{\mathbf{X}}{\mathbf{R}} \quad (9.44)$$

$$\mathbf{R} = |\mathbf{Z}| \cos \theta$$

$$\mathbf{X} = |\mathbf{Z}| \sin \theta \quad (9.45)$$

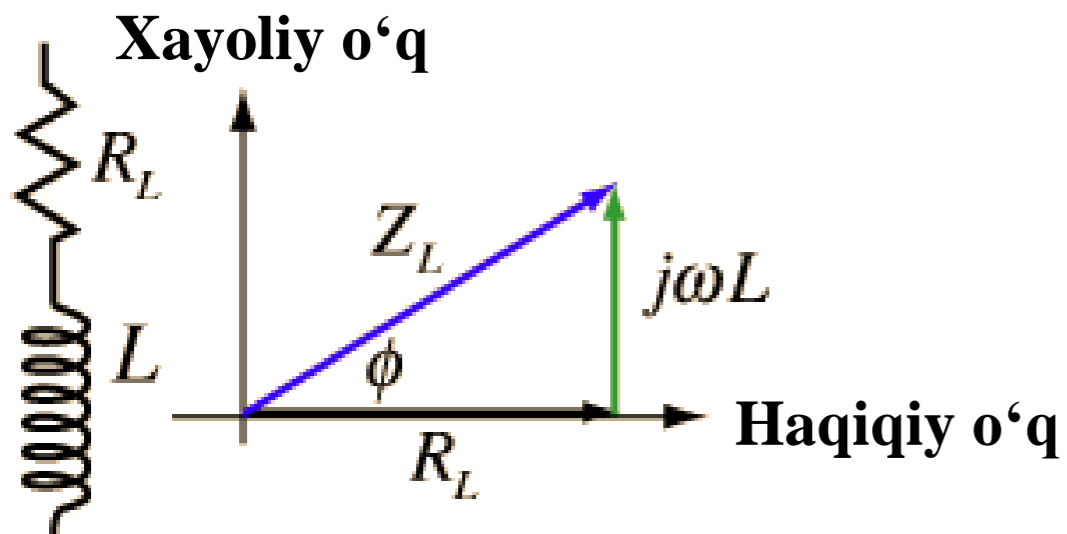

To'rtburchaklar shakli: $Z_L = R_L + j\omega L$
 Rectangular form

Qutb shakli: $Z_L = |Z_L|e^{j\phi}$
 Polar form

$$|Z_L| = \sqrt{R_L^2 + \omega^2 L^2} \quad \phi = \tan^{-1} \frac{\omega L}{R_L}$$

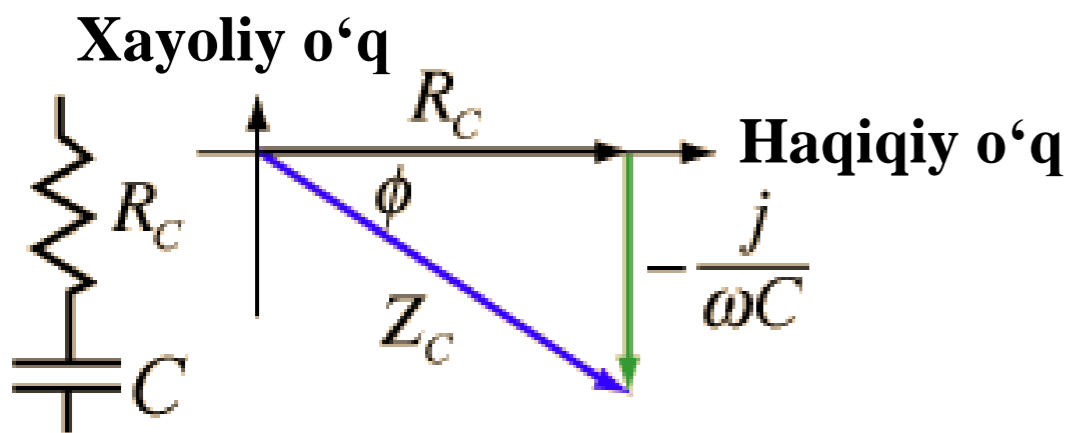

To'rtburchaklar shakli: $Z_C = R_C - \frac{j}{\omega C}$
 Rectangular form

Qutb shakli: $Z_C = |Z_C|e^{j\phi}$
 Polar form

$$|Z_C| = \sqrt{R_C^2 + \frac{-1}{\omega C R_C}} \quad \phi = \tan^{-1} \frac{-1}{\omega C R_C}$$

Zanjirlarni tahlil qilishda o‘tkazuvchanlik (*admittance*) bilan ishlash qulay.

O‘tkazuvchanlik Y - siemens (S) da o‘lchanadigan impedansning o‘zaro nisbati.

Elementning (*yoki zanjir*) o‘tkazuvchanligi - u orqali o‘tadigan faza tokining faza kuchlanishiga nisbati bilan aniqlanadi.

$$Y = \frac{1}{Z} = \frac{I}{U} \quad \text{yoki,} \quad I = YU \quad (9.46)$$

Kompleks miqdor sifatida Y ni quyidagicha yozishimiz mumkin.

$$Y = G + jB \quad (9.47)$$

bu yerda: $G = \text{Re } Y$ o‘tkazuvchanlik (*conductance*);

$B = \text{Im } Y$ o‘tkazuvchanlikka moyilligi (*susceptance*).

Admittance, conductance va susceptance siemens (yoki mo - omning o‘zaro nisbati) birligida ifodalanadi. (9.41) va (9.47) tenglamalardan,

$$G + jB = \frac{1}{R + jX} \quad (9.48)$$

Ratsionallashtirish orqali,

$$G + jB = \frac{1}{R + jX} \cdot \frac{R - jX}{R - jX} = \frac{R - jX}{R^2 + X^2} \quad (9.49)$$

Haqiqiy va xayoliy qismlarni tenglashtirish orqali,

$$G = \frac{R}{R^2 + X^2}, \quad B = -\frac{X}{R^2 + X^2} \quad (9.50)$$

Bu $G \neq 1/R$ ni qarshilik zanjirlarida bo‘lgani kabi ko‘rsatadi. Agar $X = 0$ bo‘lsa, $G = 1/R$.

ElectricalEngineering.XYZ

Conductance	Susceptance	Admittance
Reciprocal of Resistance	Reciprocal of reactance	Reciprocal of impedance
Symbol is G	Symbol is B	Symbol is Y
$G = 1/R$	$B = 1/X$	$Y = 1/Z$
Unit is siemens	Unit is siemens	Unit is siemens

Photo source: [17] - <https://www.electricalengineering.xyz/wp-content/uploads/2020/11/difference-between-conductance-susceptance-and-admittance.png>

9.5.1-masala: 9.14-rasmda ko‘rsatilgan zanjirdagi $u(t)$ va $i(t)$ larni toping.

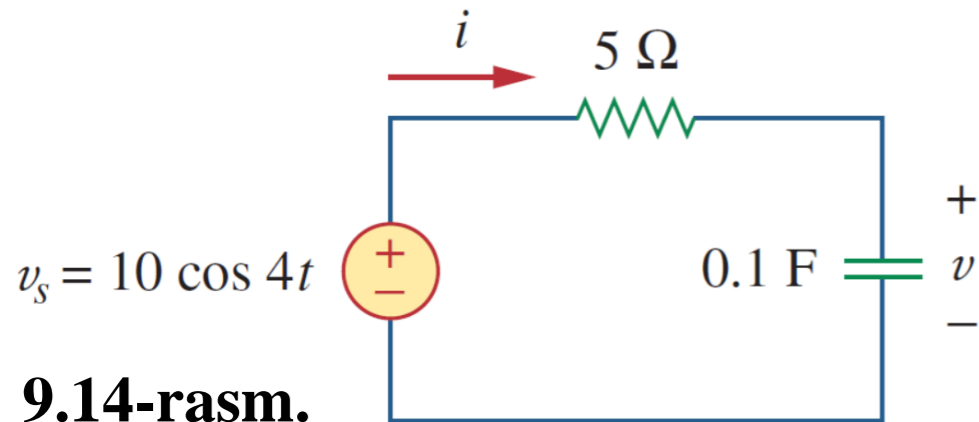

Yechilishi:

$$10 \cos 4t, \omega = 4$$

$$U_S = 10 \angle 0^\circ \text{ V}$$

$$Z_{um} = Z_R + Z_C = 5 + \frac{1}{j\omega C} = 5 + \frac{1}{j4 \cdot 0,1} = 5 - j2,5 \Omega$$

$$I = \frac{U_S}{Z} = \frac{10 \angle 0^\circ}{5 - j2,5} = \frac{10(5 + j2,5)}{(5 - j2,5)(5 + j2,5)} = \frac{50 + j25}{31,25} = 1,6 + j0,8 = 1,789 \angle 26,57^\circ \text{ A} \quad (9.5.1)$$

Kondensatordan o‘tuvchi kuchlanish,

$$j = 1 \angle 90^\circ$$

$$U = IZ_C = \frac{I}{j\omega C} = \frac{1,789 \angle 26,57^\circ}{0,4 \angle 90^\circ} = 4,47 \angle -63,43^\circ \text{ V} \quad (9.5.2)$$

(9.5.1) va (9.5.2) tenglamalardagi I va U ni vaqt sohasiga aylantirsak,

$$i(t) = 1,789 \cos(4t + 26,57^\circ) \text{ A}$$

$$u(t) = 4,47 \cos(4t - 63,43^\circ) \text{ V}$$

9.6. Chastotalar sohasida Kirxgof qonunlari.

Kirxgofning tok kuchi va kuchlanish qonunlarisiz chastota sohasida zanjir tahlilini amalga oshira olmaymiz. Shuning uchun biz ularni chastota sohasida ifodalashimiz kerak.

KVL uchun yopiq kontur atrofida u_1, u_2, \dots, u_n kuchlanishlar bo'lsin. Keyin,

$$u_1 + u_2 + \dots + u_n = 0 \quad (9.51)$$

Sinusoidal barqaror holatda har bir kuchlanish *cos* shaklida yozilishi mumkin, shuning uchun (9.51) tenglama quyidagi ko'rinshga keladi.

$$U_{m1} \cos(\omega t + \theta_1) + U_{m2} \cos(\omega t + \theta_2) + \dots + U_{mn} \cos(\omega t + \theta_n) = 0 \quad (9.52)$$

$$U_{m1} \cos(\omega t + \theta_1) + U_{m2} \cos(\omega t + \theta_2) + \dots + U_{mn} \cos(\omega t + \theta_n) = 0 \quad (9.52)$$

Buni quyidagicha yozish mumkin.

yoki,
$$\operatorname{Re}(U_{m1} e^{j\theta_1} e^{j\omega t}) + \operatorname{Re}(U_{m2} e^{j\theta_2} e^{j\omega t}) + \dots + \operatorname{Re}(U_{mn} e^{j\theta_n} e^{j\omega t}) = 0$$

$$\operatorname{Re}[(U_{m1} e^{j\theta_1} + U_{m2} e^{j\theta_2} + \dots + U_{mn} e^{j\theta_n} e^{j\omega t}) e^{j\omega t}] = 0 \quad (9.53)$$

Agar $U_k = U_{mk} e^{j\theta_k}$ bo'lsa,

$$\operatorname{Re}[(U_1 + U_2 + \dots + U_n) e^{j\omega t}] = 0 \quad (9.54)$$

Shunday qilib $e^{j\omega t} \neq 0$,

$$U_1 + U_2 + \dots + U_n = 0 \quad (9.55)$$

fazalar uchun Kirxgofning kuchlanish qonuni amal qilishini ko'rsatadi.

Shunga o‘xshash jarayonga rioya qilish orqali biz Kirxgofning amaldagi qonuni fazalar uchun amal qilishini ko‘rsatishimiz mumkin. Agar i_1, i_2, \dots, i_n t vaqtda tarmoqdagi yopiq tugundan chiqib ketayotgan yoki kiruvchi tok bo‘lsin, u holda

$$i_1 + i_2 + \dots + i_n = 0 \quad (9.56)$$

Agar I_1, I_2, \dots, I_n sinusoidlarning i_1, i_2, \dots, i_n faza shakllari bo‘lsa, u holda

$$I_1 + I_2 + \dots + I_n = 0 \quad (9.55)$$

bu Kirxgofning chastotalar sohasidagi tok kuchi bilan bog‘liq qonunidir.

KVL va KCL chastotalar sohasida ushlab turishini ko‘rsatganimizdan so‘ng, impedans kombinatsiyasi, tugun va tarmoq tahlillari, superpozitsiya va manba transformatsiyasi kabi ko‘p narsalarni qilish oson.

FOYDALANILGAN MANBALAR:

11. https://blogger.googleusercontent.com/img/b/R29vZ2xl/AVvXsEisX89LUX0SaruLITujBF9tALzagqfyDJsEOzpROa53G136gCtxnasB_6_JwXg39Bf7phQzpKxJNWvY5yLwO8Dm5F-QjI4pLcWmmir6_qloHI1baqv_kYIVgBgPyu5GxkdYRMPthqMPrVnBGuehQOelBnAFz3XelQr2n2TSzSPLmCjv6_e9V-U65YLv/w320-h240/resistance%20versus%20impedance.png
12. https://solderingmind.com/?attachment_id=1530
13. <https://i0.wp.com/www.electricalvolt.com/wp-content/uploads/2023/02/resistance.png?fit=940%2C788&ssl=1>
14. <https://ecstudiosystems.com/discover/textbooks/basic-electronics/ac-circuits/images/impedance-on-complex-plane.jpg>
15. <https://i.stack.imgur.com/pvJPd.png>
16. <https://i.stack.imgur.com/x2Gjs.gif>
17. <https://www.electricalengineering.xyz/wp-content/uploads/2020/11/difference-between-conductance-susceptance-and-admittance.png>



*E'TIBORINGIZ
UCHUN
RAHMAT!!!*