

## 10-Mavzu: Sinusoidal barqaror holat tahlili.

(10<sup>th</sup> Topic: Sinusoidal Steady-State Analysis.)

### 10-Mavzuning 2-qismi

(2<sup>nd</sup> part of the 10<sup>th</sup> Topic)

*13-hafta uchun*  
*For the 13<sup>th</sup> week*

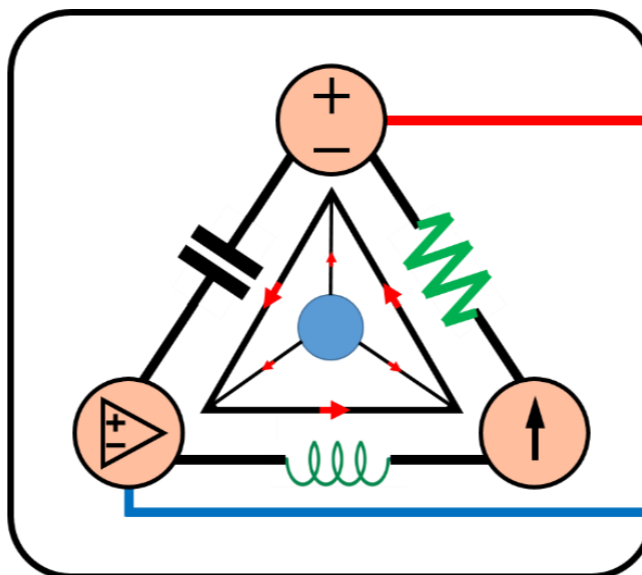

**Lecturer: Ph.D., Yusupov Sarvarbek**

*Toshkent Kimyo Xalqaro Universiteti*  
*“Mashinasozlik texnologiyasi” kafedrası*  
*Toshkent shahri, Usmon Nosir, 156-uy.*



# 10-Mavzu: Sinusoidal barqaror holat tahlili.

(10<sup>th</sup> Topic: Sinusoidal Steady-State Analysis.)

## O'quv rejasi:

10.1. Umumiy tushunchalar.

10.2. Tugun potentsiallar tahlili.

10.3. Mesh (to'r) tahlili.

10.4. Superpozitsiya (ustma-ustlash) teoremasi.

**10.5. Manba transformatsiyasi.**

**10.6. Tevenin va Norton ekvivalent zanjirlari.**

**10.7. O'zgaruvchan tok zanjirlarida operatsion kuchaytirgichlar.**

**10.8. Qo'llanilishi.**

## 10.5. Manba transformatsiyasi.

Chastota sohasida manba transformatsiyasini amalga oshirishda kuchlanish manbasi impedans bilan ketma-ket holatda, tok kuchi manbai bilan esa parallel holatda joylashtiriladi.

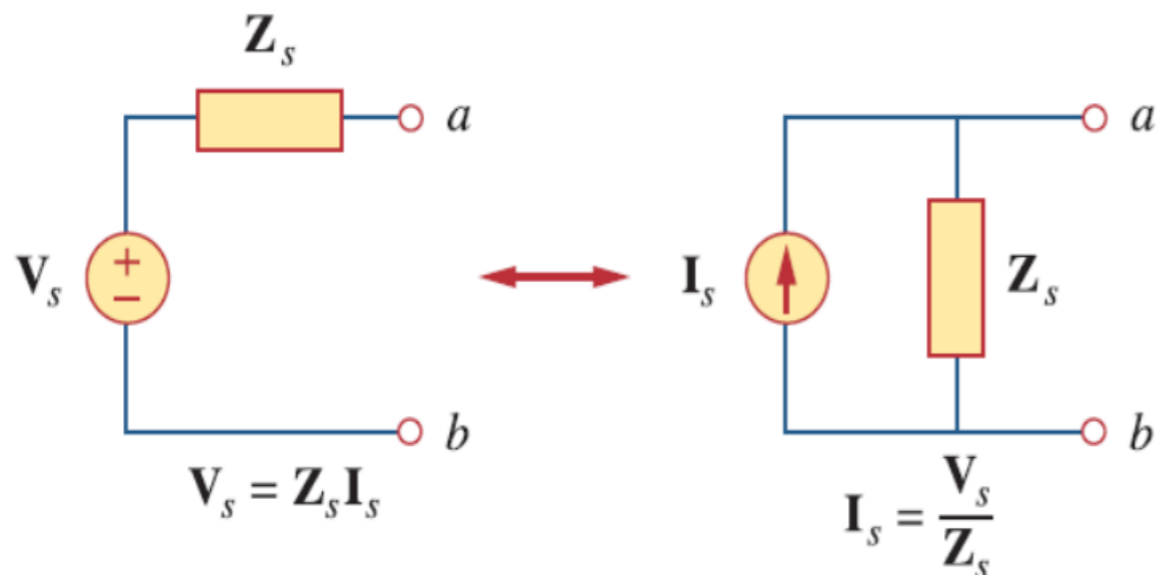

10.6-rasm.

Bir manba turidan ikkinchisiga o'tayotganda, biz quyidagi munosabatlarni yodda tutishimiz kerak:

$$U_S = Z_S I_S \quad \leftrightarrow \quad I_S = \frac{U_S}{Z_S} \quad (10.1)$$

# 10.5.1-masala: 10.7-rasmda ko'rsatilgan zanjirdagi $U_x$ ni manba transformatsiyasi metodidan

foydalanib hisoblang.

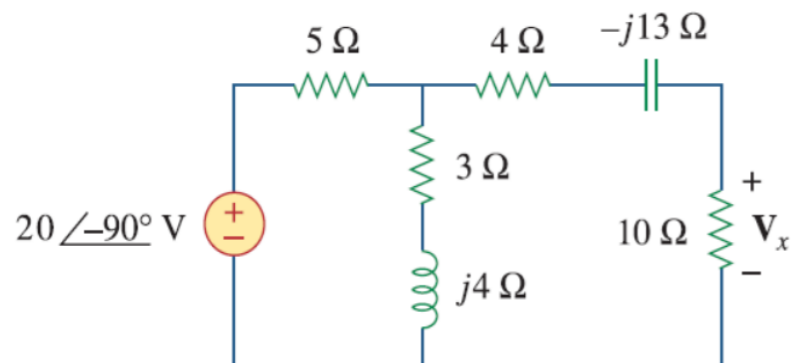

10.7-rasm.

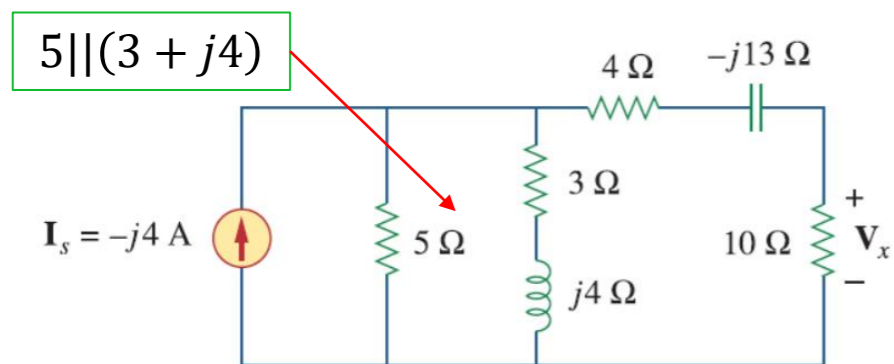

**Yechish:**

$$I_s = \frac{20 \angle -90^\circ}{5} = 4 \angle -90^\circ = -j4 \text{ A}$$

$$V_s = 5 - j10 \text{ V}$$

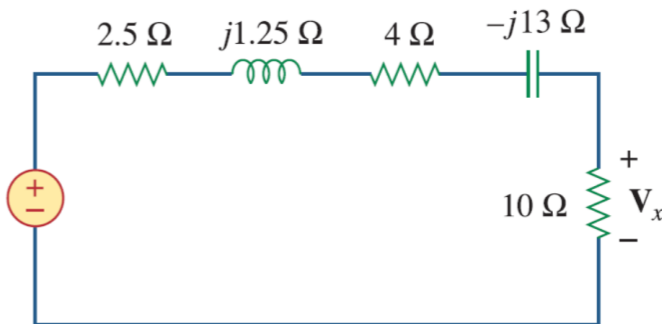

$$U_s = I_s Z_1 = -j4 (2,5 + j1,25) = 5 - j10 \text{ V}$$

$$\text{VDR: } U_x = \frac{10}{10 + 2,5 + j1,25 + 4 - j13} (5 - j10) = \frac{10}{16,5 - j11,75} (5 - j10) =$$

$$= \frac{10(16,5 + j11,75)}{(16,5 - j11,75)(16,5 + j11,75)} (5 - j10) = \frac{165 + j117,5}{16,5^2 + 11,75^2} (5 - j10) =$$

$$= \frac{165 + j117,5}{410,31} (5 - j10) = (0,402 + j0,286)(5 - j10) =$$

$$= (2,01 - j4,02 + j1,43 - j^2 2,86) = 4,87 - j2,59.$$

$$|z| = \sqrt{4,87^2 + 2,59^2} = 5,51$$

$$\theta = \arctg \frac{2,59}{4,87} = \arctg 0,5318 = 28,00^\circ$$

$$U_x = 5,51 \angle -28^\circ \text{ V}$$

$$Z_1 = \frac{5(3 + j4)}{8 + j4} = \frac{5(3 + j4)(8 - j4)}{(8 + j4)(8 - j4)} = \frac{5(24 - j12 + j32 - j^2 16)}{64 + 16} =$$

$$= \frac{5(40 + j20)}{64 + 16} = \frac{200 + j100}{80} = 2,5 + j1,25 \Omega$$

## 10.6. Tevenin va Norton ekvivalent zanjirlari.

Tevenin va Norton teoremlari o'zgarmas tok zanjirlarda qo'llanilgan kabi o'zgaruvchan tok zanjirlarida ham bir xil qo'llaniladi.

Faqatgina qo'shimcha maqsadda kompleks sonlarni manipulyatsiya qilish zaruratidan kelib chiqadi.

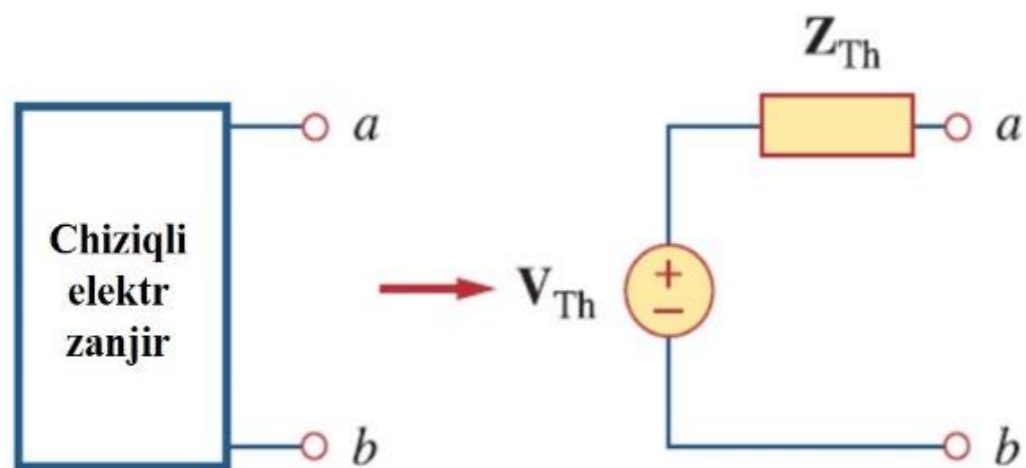

a)

**10.8-rasm.**

Tevenin ekvivalent zanjirining chastota sohasi 10.8-rasm, *a* da tasvirlangan, bu yerda chiziqli zanjiri kuchlanish manbai bilan impedans ketma-ket joylashtirib almashtiriladi.

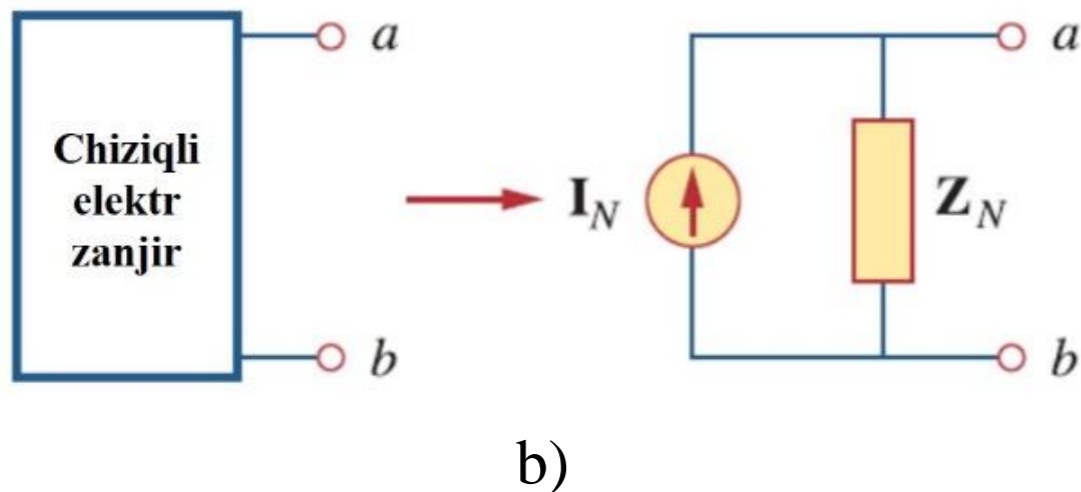

b)  
10.8-rasm.

Norton ekvivalent zanjiri 10.8-rasm,  $b$  da tasvirlangan, bunda chiziqli zanjiri tok kuchi manbai bilan impedans parallel joylashtirib almashtiriladi.

Shuni yodda tutish kerakki, ikkita ekvivalent zanjirlar xuddi manba transformatsiyasida bo‘lgani kabi bog‘liqdir.

$$U_{Th} = Z_{Th} I_N, \quad Z_{Th} = Z_N \quad (10.2)$$

$U_{Th}$  ochiq tutashuv kuchlanishi,  $I_N$  esa qisqa tutashuv toki.

Agar zanjir turli chastotalarda ishlaydigan manbalarga ega bo'lsa, Tevenin yoki Norton ekvivalent zanjiri har bir chastotada aniqlanishi kerak.

Bu ekvivalent manbalar va ekvivalent impedenslarga ega bo'lgan bir ekvivalent zanjiri emas, balki har bir chastota uchun bittadan mutlaqo boshqa ekvivalent zanjirlarga olib keladi.

# 10.6.1-masala: 10.9-rasmda ko'rsatilgan zanjirning $a - b$ terminallarida Tevenin ekvivalentini

hosil qiling.

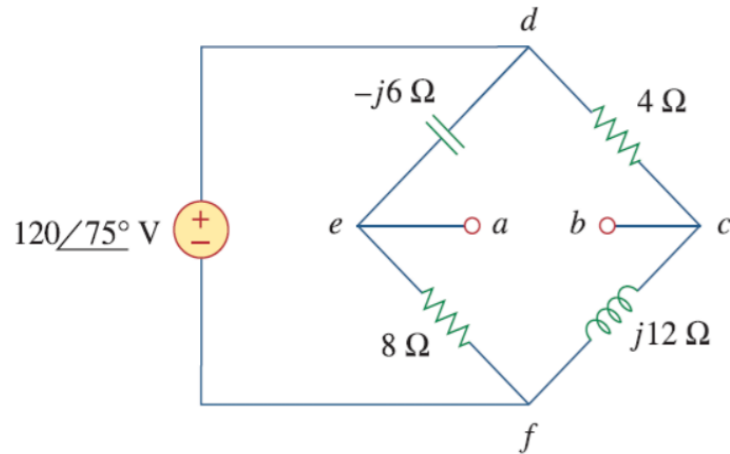

10.9-rasm.

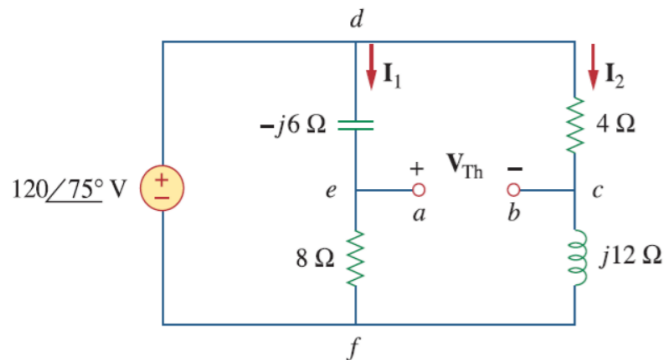

$U_{Th} = ?$

$$I_1 = \frac{120 \angle 75^\circ}{8 - j6} \text{ A}; \quad I_2 = \frac{120 \angle 75^\circ}{4 + j12} \text{ A}.$$

**Yechish:**

$$Z_{Th} = ?$$

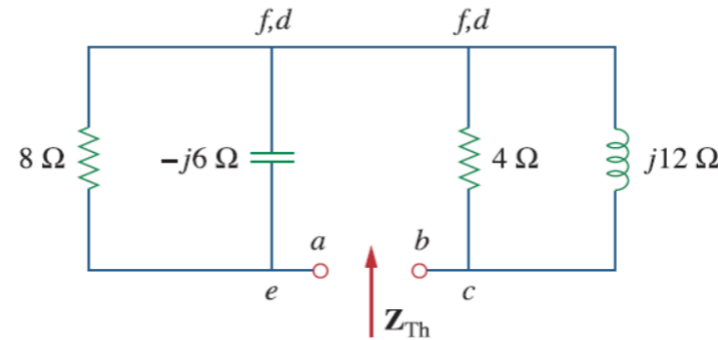

$$Z_1 = -j6 \parallel 8 = \frac{-j6 \cdot 8}{8 - j6} = \frac{-j48(8 + j6)}{(8 - j6)(8 + j6)} = \frac{288 - j384}{100} = 2,88 - j3,84 \Omega$$

$$Z_2 = 4 \parallel j12 = \frac{j12 \cdot 4}{4 + j12} = \frac{j48(4 - j12)}{(4 + j12)(4 - j12)} = \frac{576 + j192}{160} = 3,6 + j1,2 \Omega$$

$$Z_{Th} = Z_1 + Z_2 = 2,88 - j3,84 + 3,6 + j1,2 = 6,48 - j2,64 \Omega$$

**bcdeab atrofida KVL ni qo'llaymiz:**

$$U_{Th} - 4I_2 + (-j6)I_1 = 0$$

$$U_{Th} = 4I_2 + j6I_1 =$$

$$= \frac{480 \angle 75^\circ}{4 + j12} + \frac{720 \angle 75^\circ + 90^\circ}{8 - j6} =$$

$$= \frac{480 \angle 75^\circ}{12,649 \angle 71,57^\circ} + \frac{720 \angle 165^\circ}{10 \angle -36,87^\circ} =$$

$$= 37,95 \angle 3,43^\circ + 72 \angle 201,87^\circ =$$

$$= -28,936 - j24,55 = 37,95 \angle 220,31^\circ \text{ V}$$

$$Z_{Th} = 6,48 - j2,64 \Omega$$

$$U_{Th} = 37,95 \angle 220,31^\circ \text{ V}$$

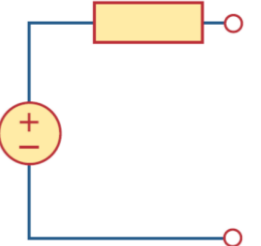

# 10.6.2-masala: 10.11-rasmda ko'rsatilgan zanjirdagi $I_0$ tok kuchini Norton

teoremasidan foydalanib aniqlang.

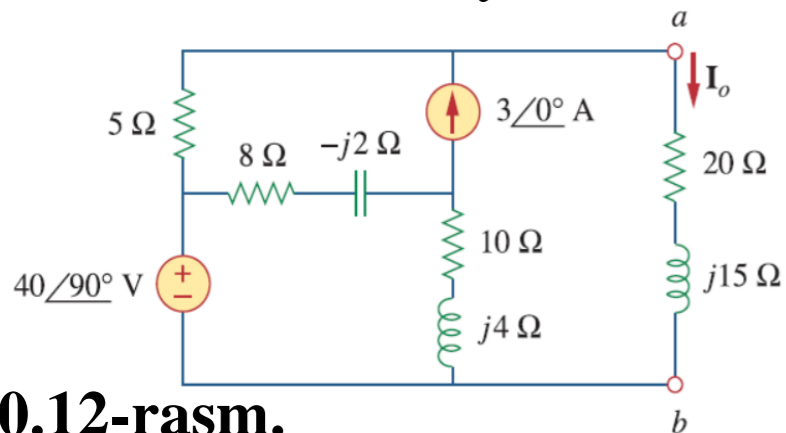

10.12-rasm.

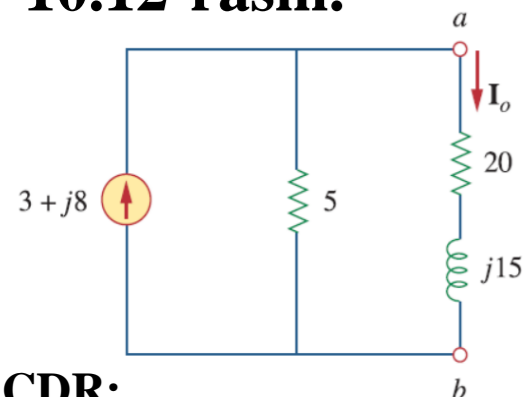

CDR:

$$I_0 = \frac{5}{5 + 20 + j15} I_N = \frac{3 + j8}{5 + j3} = \frac{(3 + j8)(5 - j3)}{(5 + j3)(5 - j3)}$$

$I_0 = ?$

$$-j40 + 5 I_2 = 0 \rightarrow I_2 = j8$$

$$= \frac{15 - j9 + j40 - j^2 24}{5^2 + 3^2} = \frac{39 + j31}{34} = 1,147 + j0,91$$

$$|z| = \sqrt{1,147^2 + 0,91^2} = 1,464$$

$$\theta = \arctg \frac{0,91}{1,147} = \arctg 0,7933 = 38,42^\circ$$

**Yechish:**

Impidenslar qisqa tutashgan

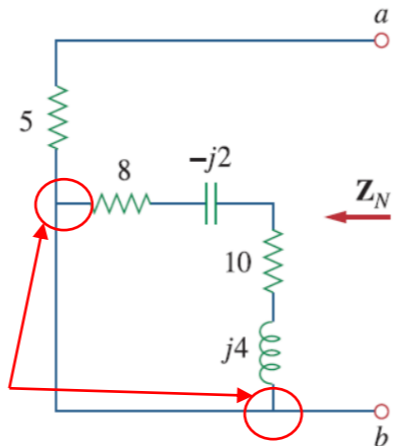

$Z_N = 5 \Omega$

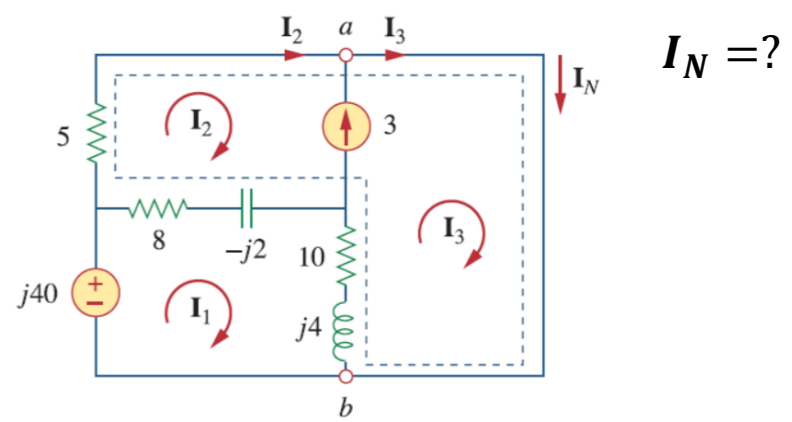

1-mesh uchun,

$$-j40 + (18 + j2) I_1 - (8 - j2) I_2 - (10 + j4) I_3 = 0$$

Supermesh uchun,

$$(13 - j2) I_2 + (10 + j4) I_3 - (18 + j2) I_1 = 0$$

$a$  tugunida, 2 va 3 to'rlar orasidagi tok kuchi manbai

$$I_3 = I_2 + 3$$

$$I_3 = I_2 + 3 = 3 + j8$$

Norton tok kuchi,

$$I_N = I_3 = (3 + j8)A$$

**$I_0 = 1,464 \angle 38,48^\circ A$**

## 10.7. O'zgaruvchan tok zanjirlarida operatsion kuchaytirgichlar.

1. Zanjirni faza yoki chastota sohasiga aylantirish.

2. Masalani zanjir usullari (tugun tahlili, to'r tahlili, superpozitsiya va boshqalar) yordamida yechish.

3. Olingan fazaviy natijani vaqt sohasiga aylantirish.

Ushbu uchta bosqichlar agar operatsion kuchaytirgich chiziqli mintaqada ishlayotgan bo'lsa, operatsion kuchaytirgich zanjirlariga ham tegishli.

Odatdagidek, biz ideal operatsion kuchaytirgichlarni qabul qilamiz.

Operatsion kuchaytirgichlarni tahlil qilishning kaliti ideal operatsion kuchaytirgich ikkita muhim xususiyatini yodda tutish kerak.

Bular:

1. Hech qanday tok kuchi uning kirish terminallariga kirmaydi.
2. Uning kirish terminallaridagi kuchlanish nolga teng.

### 10.7.1-masala: 10.13-rasmda ko'rsatilgan operatsion kuchaytirgich zanjiridagi $u_0(t)$

kuchlanishni aniqlang.  $U_S = 3 \cos 1000 t \text{ V}$ .

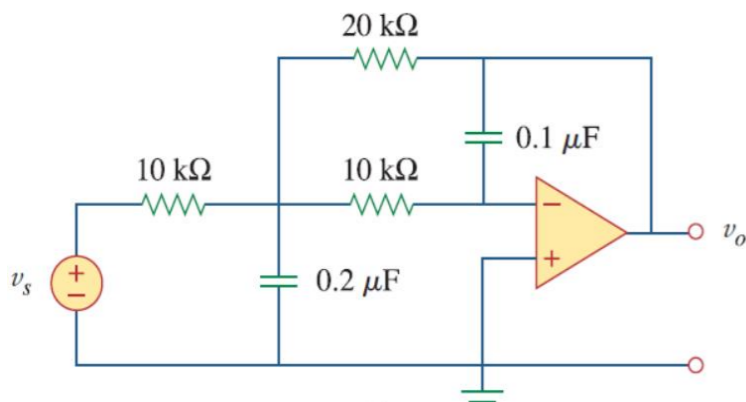

a) Vaqt sohasidagi asl zanjir;

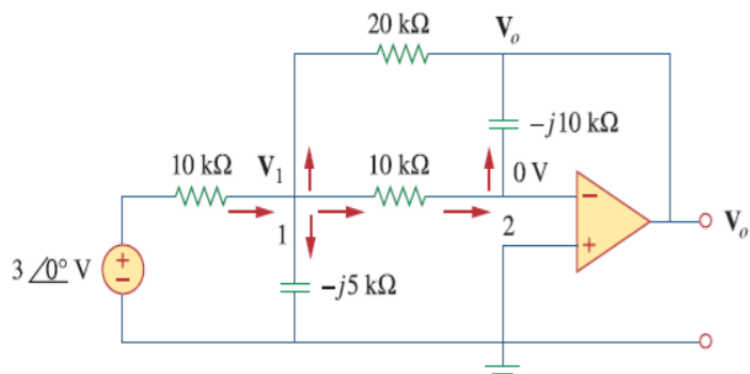

b) Uning chastota sohasidagi ekvivalenti.

#### 10.13-rasm.

**Yechish:**

**1**

$$U_S = 3\angle 0^\circ, \quad \omega = 1000 \text{ rad/s.}$$

$$Z_{C1} = \frac{1}{j \cdot 1000 \cdot 0,1 \cdot 10^{-6}} = -j10 \text{ k}\Omega; \quad Z_{C2} = \frac{1}{j \cdot 1000 \cdot 0,2 \cdot 10^{-6}} = -j5 \text{ k}\Omega.$$

**2**

**1-tugun uchun KCL:**

$$\frac{3\angle 0^\circ - V_1}{10} = \frac{V_1}{-j5} + \frac{V_1 - 0}{10} + \frac{V_1 - V_0}{20} \rightarrow 6 = (5 + j4)V_1 - V_0$$

**2-tugun uchun KCL:**

$$\frac{V_1 - 0}{10} = \frac{0 - V_0}{-j10} \rightarrow V_1 = -jV_0$$

$$6 = -j(5 + j4)V_0 - V_0 = (3 - j5)V_0$$

$$V_0 = \frac{6}{3 - j5} = \frac{6(3 + j5)}{(3 - j5)(3 + j5)} = \frac{18 + j30}{34} = 0,52 + j0,88 = 1,29\angle 59,42^\circ$$

$$|z| = \sqrt{0,52^2 + 0,88^2} = 1,29$$

**3**

$$u_0(t) = 1,29 \cos(1000 t + 59,42^\circ) \text{ V}$$

$$\theta = \arctg \frac{0,88}{0,52} = \arctg 1,692 = 59,42$$

## 10.8. Qo'llanilishi.

Ushbu mavzuda o'rganilgan tushunchalar keyingi mavzularda elektr quvvatini hisoblash va chastota reaksiyasini aniqlash uchun qo'llaniladi.

Tushunchalar, shuningdek, bog'langan zanjirlar (coupled circuits), uch fazali zanjirlar, o'zgaruvchan tok tranzistor zanjirlari, filtrlar, osilatorlar va boshqa o'zgaruvchan tok zanjirlarni tahlil qilishda qo'llaniladi.

Ushbu bo'limda biz ikkita amaliy o'zgaruvchan tok zanjirlarini ishlab chiqish uchun konsepsiyalarni qo'llaymiz: sig'im ko'paytiruvchisi va sinus to'lqin osilatorlari.

### sig'im ko'paytiruvchi

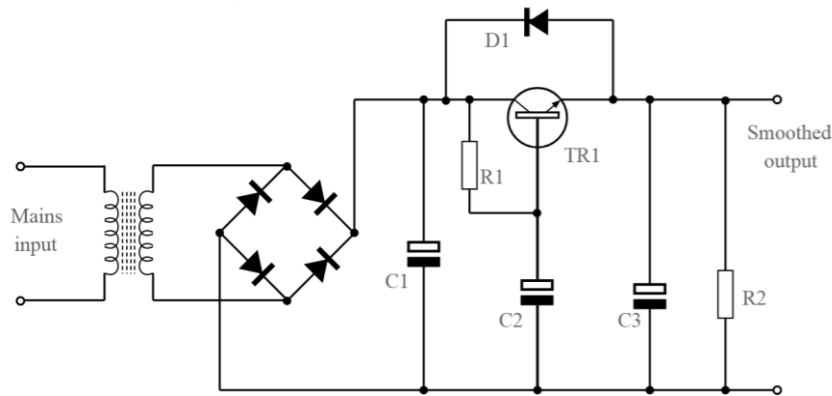

Photo source: [3] - <https://www.electronics-notes.com/images/transistor-capacitance-multiplier-example-application-01.svg>

### sinus to'lqin osilatori

What is an Oscillator?

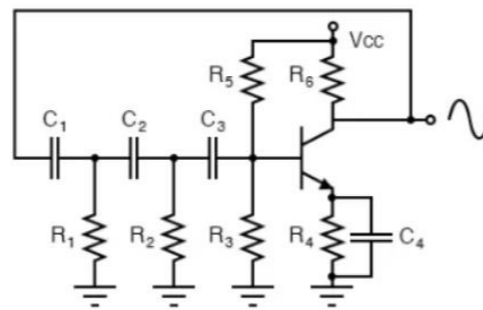
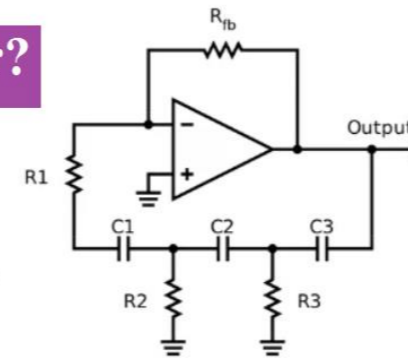

Photo source: [4] - <https://www.knowelectronic.com/wp-content/uploads/2022/03/what-is-an-oscillator.png>



### 10.8.1 Sig‘im ko‘paytiruvchisi.

Ushbu operatsion kuchaytirgich zanjiri aniq bo‘ladigan sabablarga ko‘ra sig‘im ko‘paytmasi sifatida tanilgan.

Bunday zanjir integrallashgan zanjir texnologiyasida katta sig‘im kerak bo‘lganda kichik fizik sig‘imning  $C$  katta qiymatini hosil qilish uchun ishlatiladi.

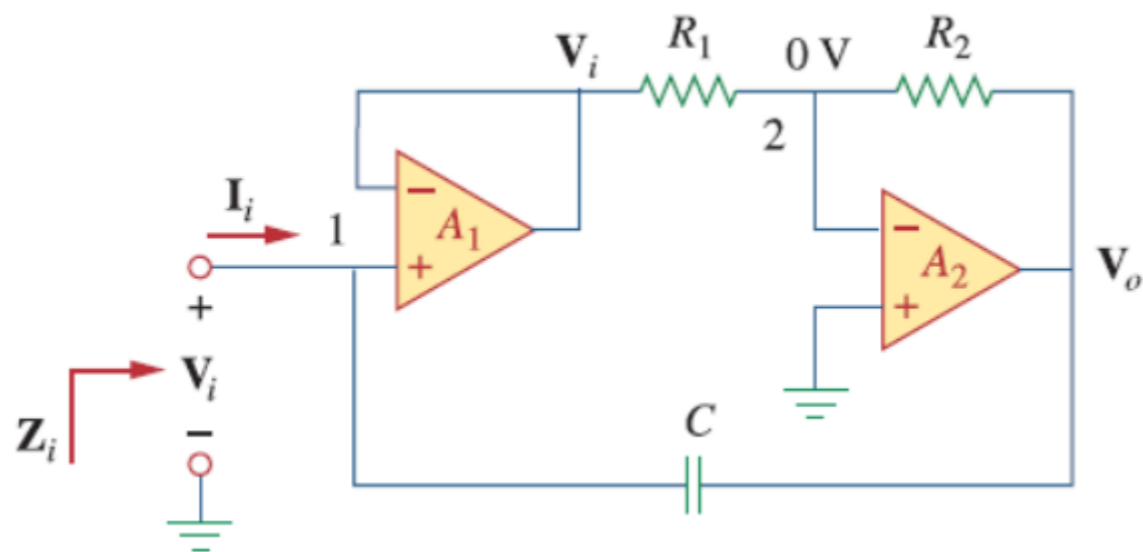

**10.14-rasm. Sig‘im ko‘paytiruvchi.**

Bu zanjir sig‘im qiymatlarini 1000 koeffitsientga ko‘paytirish uchun ishlatilishi mumkin.

Misol uchun, 10-pF sig‘imli kondensator 100-nF sig‘imli kondensator kabi hosil qilinishi mumkin.

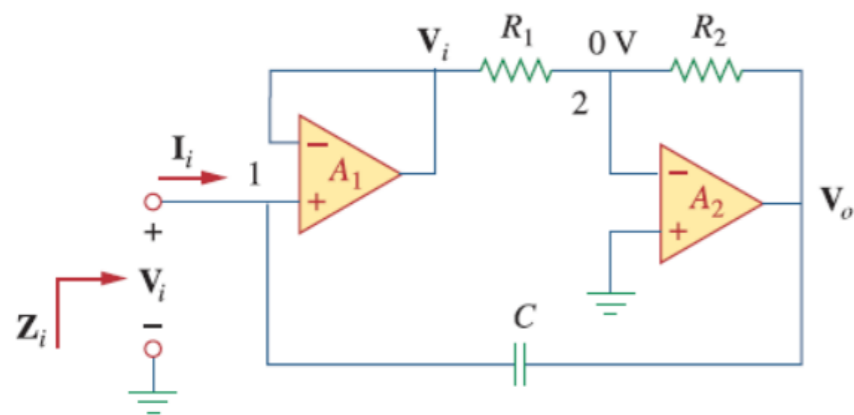

Birinchi operatsion kuchaytirgich kuchlanish takrorlagichi (*voltage follower*) sifatida ishlaydi, ikkinchisi esa inverting kuchaytirgichdir.

Operatsion kuchaytirgichning kirish terminallariga tok kuchi kirmaganligi sababli, kiruvchi tok kuchi  $I_i$  qayta aloqa, kondensator orqali harakatlanadi.

1-tugun uchun,

$$I_i = \frac{U_i - U_o}{1/j\omega C} = j\omega C (U_i - U_o) \quad (10.3)$$

2-tugun uchun KCL ni qo‘llaymiz:  $\frac{U_i - 0}{R_1} = \frac{0 - U_o}{R_2}$  yoki  $U_o = \frac{R_2}{R_1} U_i$  (10.4)

$$I_i = j\omega C \left(1 + \frac{R_2}{R_1}\right) U_i \quad \text{yoki} \quad \frac{I_i}{U_i} = j\omega \left(1 + \frac{R_2}{R_1}\right) C \quad (10.5)$$

Kiruvchi impedans:  $Z_i = \frac{U_i}{I_i} = \frac{1}{j\omega C_{um}}$  (10.6)

$$C_{um} = \left(1 + \frac{R_2}{R_1}\right) C \quad (10.7)$$

**10.8.1-masala:** 10.14-rasmdagi  $C_{um}$  ni hisoblang.

$R_1 = 10\text{ k}\Omega$ ,  $R_2 = 1\text{ M}\Omega$  va  $C = 1\text{ nF}$  berilgan bo'lsin.

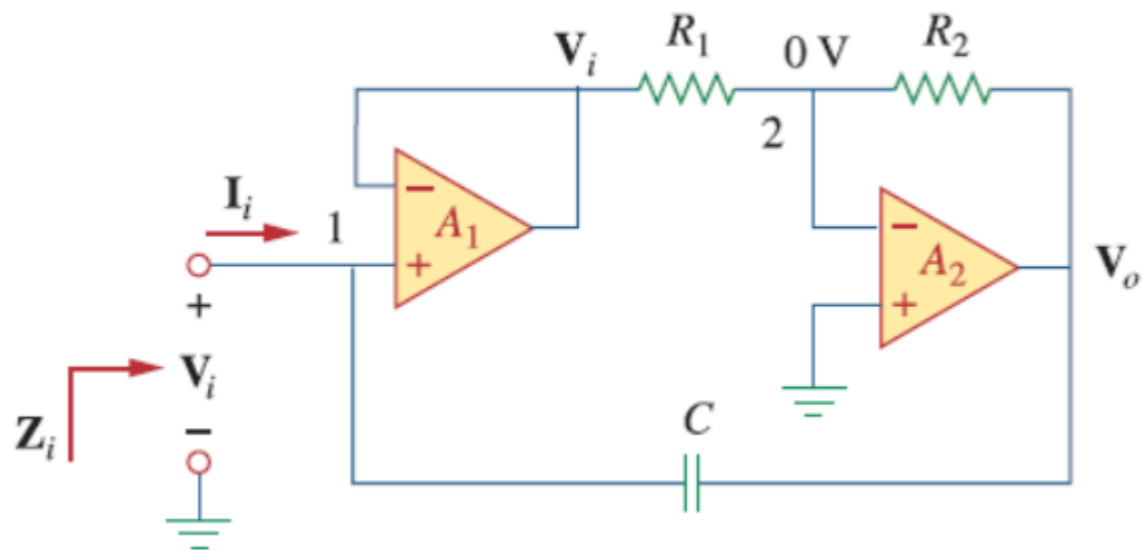

**Yechish:**

**10.14-rasm.**

$$C_{um} = \left(1 + \frac{R_2}{R_1}\right) C = \left(1 + \frac{1 \cdot 10^6}{10 \cdot 10^3}\right) = 1\text{ nF} = 101\text{ nF}$$

## 10.8.2 Otsilatorlar.

Biz bilamizki, o'zgarmas tok batareyalar tomonidan ishlab chiqariladi. Lekin biz qanday qilib o'zgaruvchan tokni ishlab chiqaramiz? Buning usullaridan biri o'zgarmas tokni o'zgaruvchan tokga aylantiradigan otsilator zanjirlaridan foydalanishdir.

Otsilator - bu o'zgarmas tok bilan quvvatlanganda chiqish sifatida o'zgaruvchan to'lqin shaklini ishlab chiqaradigan zanjirdir.

Otsilatorga kerak bo'lgan yagona tashqi manba o'zgarmas tok manbaidir.

O'zgarmas quvvat manbai, odatda, elektr ta'minoti korxonasi tomonidan ta'minlangan o'zgaruvchan tokni o'zgarmas tokga aylantirish orqali olinadi.

Konvertatsiya qilish bilan bog'liq muammolar orqali nima uchun biz o'zgarmas tokni yana o'zgaruvchan tokga aylantirish uchun osilatordan foydalanishimiz kerakligi haqida savol tug'ilishi mumkin.

Muammo shundaki, kommunal xo‘jaligi korxonalarda ishlab chiqilgan o‘zgaruvchan tok AQSh da 60 Hz chastotada ishlaydi (*ba’zi boshqa mamlakatlarda 50 Hz*), elektron zanjirlar, aloqa tizimlari va mikroto‘lqinli qurilmalarda ichki ishlab chiqarilgan chastotalarni talab qiladi

0 dan 10 gigagersgacha yoki undan yuqori diapazonda. Ushbu chastotalarni ishlab chiqarish uchun osilatorlardan foydalaniladi.

Sinus to‘lqinli otsilatorlar tebranishlarni ushlab turishi uchun ular Barxuazen (*Barkhausen*) mezonlariga javob berishi kerak:

1. Otsilatorning umumiy qiymati birlik yoki undan ko‘p bo‘lishi kerak. Shuning uchun yo‘qotishlar kuchaytiruvchi qurilma bilan qoplanishi kerak.
2. Umumiy faza almashinuvi (*kirishdan chiqishga va kirishga qaytib*) nolga teng bo‘lishi kerak.

sinus to‘lqinli otsilatorlarning uchta keng tarqalgan turi - fazali siljish, egizak T va Vien-ko‘prikli otsilatorlar mavjud.

Miqdorni nazorat qilish  
uchun salbiy teskari  
aloqa yo‘li

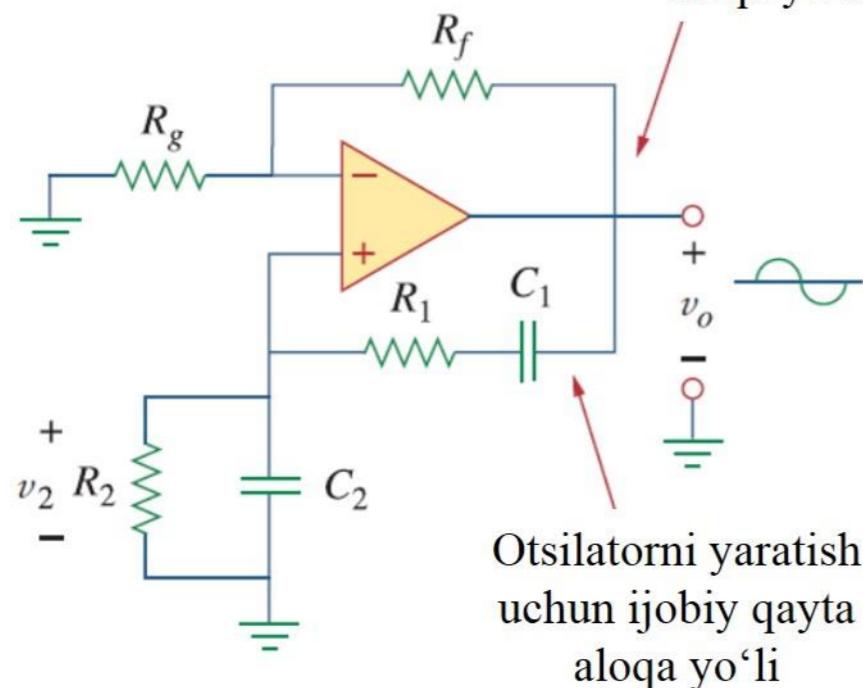

Otsilatorni yaratish  
uchun ijobiy qayta  
aloqa yo‘li

Vien-ko‘prikli otsilator 1 MGts dan past chastota diapazonida sinusoidlarni hosil qiladi.

Bu RC operatsion kuchaytirgich zanjiri bo‘lib, bir nechta komponentlarga ega, oson sozlanishi va konstruksiyasi oson.

Otsilator asosan ikkita qayta aloqa yo‘li bo‘lgan teskari bo‘lmagan kuchaytirgichdan iborat: teskari bo‘lmagan kirishga ijobiy qayta aloqa yo‘li tebranishlarni hosil qiladi, inverting kirishiga salbiy qayta aloqa yo‘li esa qiymatni boshqaradi.

**10.15-rasm. Vien-ko‘prik otsilatori.**

Photo source: [6] -Fundamentals of Electric Circuits, Charles K. Alexander and Matthew N. O. Sadiku / 5th edition, the McGraw-Hill Companies, Inc., -2013. – p 439.

Agar biz RC ketma-ket va parallel birikmalarning impedenslarini  $Z_1$  va  $Z_2$  deb belgilasak, u holda

$$Z_s = R_1 + \frac{1}{j\omega C_1} = R_1 - \frac{j}{\omega C_1} \quad (10.8)$$

$$Z_p = R_2 \parallel \frac{1}{j\omega C_2} = \frac{R_2}{1 + j\omega R_2 C_2} \quad (10.9)$$

Qayta aloqa nisbati,

$$\frac{U_2}{U_0} = \frac{Z_p}{Z_s + Z_p} \quad (10.10)$$

(10.8) va (10.9) tenglamalrni (10.10) ga almashtirib quyidagiga ega bo'lamiz.

$$\frac{U_2}{U_0} = \frac{R_2}{R_2 + (R_1 - \frac{j}{\omega C_1})(1 + j\omega R_2 C_2)} = \frac{\omega R_2 C_1}{\omega(R_2 C_1 + R_1 C_1 + R_2 C_2) + j(\omega^2 R_1 C_1 R_2 C_2 - 1)} \quad (10.11)$$

Ikkinchi Barxauzen mezonini qondirish uchun  $U_2$   $U_o$  bilan fazada bo‘lishi kerak, bu esa (10.11) tenglamadagi nisbat faqat haqiqiy bo‘lishi kerakligini anglatadi.

Demak, hayoliy qism nolga teng bo‘lishi kerak. Hayoliy qismni nolga teng qilib belgilash otsilator chastotasini  $\omega_o$  quyidagiga teng bo‘ladi.

$$\omega^2 R_1 C_1 R_2 C_2 - 1 = 0 \quad \text{yoki,} \quad \omega_o = \frac{1}{\sqrt{R_1 R_2 C_1 C_2}} \quad (10.12)$$

$$\omega_o = \frac{1}{RC} = 2\pi f_o \quad (10.13) \quad \text{yoki,} \quad f_o = \frac{1}{2\pi RC} \quad (10.14)$$

(10.13) tenglamani va  $R_1 = R_2 = R$ ,  $C_1 = C_2 = C$  larni (10.11) tenglamaning xadlariga almashtirsak,

$$\frac{U_2}{U_o} = \frac{1}{3} \quad (10.15)$$

Shunday qilib, birinchi Barkxauzen mezonini qondirish uchun operatsion kuchaytirgich 3 yoki undan ortiq qiymatni ta'minlash orqali kompensatsiya qilishi kerak, shunda umumiy qiymat kamida 1 yoki birlik bo'ladi. To'g'ri kuchaytirgich uchun,

$$\frac{U_2}{U_o} = 1 + \frac{R_f}{R_g} = 3 \quad (10.16)$$

yoki,

$$R_f = 2R_g \quad (10.17)$$

Operatsion kuchaytirgichdan kelib chiqqan kechikish tufayli Vien-ko'prigi otsilatorlari 1 MGts yoki undan kam chastota diapazonida ishlash bilan cheklangan.



**10.8.2-masala:** 100 kHz chastotada tebranish uchun Vien-ko‘prigi zanjirini loyihalang.

**Yechish:**

$$f_o = \frac{1}{2\pi RC} \quad (10.14)$$

$$RC = \frac{1}{2\pi f_o} = \frac{1}{2\pi \cdot 100 \cdot 10^3} = 1,59 \cdot 10^{-6} \quad (10.16.1)$$

Agar biz  $R = 10 \text{ k}\Omega$  deb belgilasak,  $C = 159 \text{ pF}$  ni tashkil qilib, (10.16.1) tenglikni qanoatlantiradi.

Miqdor 3 bo‘lishi kerakligi sababli,  $\frac{R_f}{R_g} = 2$  ga teng.  $R_g = 10 \text{ k}\Omega$  bo‘lsa,  $R_f = 20 \text{ k}\Omega$  ni tanlashimis mumkin.



## ***FOYDALANILGAN MANBALAR:***

3. <https://www.electronics-notes.com/images/transistor-capacitance-multiplier-example-application-01.svg>
4. <https://www.knowelectronic.com/wp-content/uploads/2022/03/what-is-an-oscillator.png>
5. Fundamentals of Electric Circuits, Charles K. Alexander and Matthew N. O. Sadiku / 5th edition, the McGraw-Hill Companies, Inc., -2013. – p 437.
6. Fundamentals of Electric Circuits, Charles K. Alexander and Matthew N. O. Sadiku / 5th edition, the McGraw-Hill Companies, Inc., -2013. – p 439.



# TEKSHIRISH UCHUN SAVOLLAR!

10.1. 10.16-rasmdagi kondensatordan o'tuvchi  $U_o$  kuchlanishni aniqlang:

- A)  $5 \angle 0^\circ V$ .  
 B)  $7,071 \angle 45^\circ V$ .  
 C)  $7,071 \angle -45^\circ V$ .  
 D)  $5 \angle -45^\circ V$ .

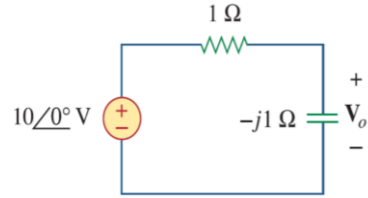

10.16-rasm.

10.2. 10.17-rasmda keltirilgan zanjirdagi tok kuchi  $I_o$  ning qiymatini aniqlang:

10.17-rasm.

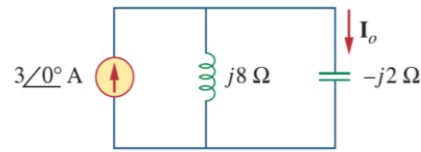

- A)  $4 \angle 0^\circ A$ .  
 B)  $2,4 \angle -90^\circ A$ .  
 C)  $0,6 \angle 0^\circ A$ .  
 D)  $-1 A$ .

10.3. 10.18-rasmda keltirilgan zanjirdagi  $U_o$  ning qiymatini tugun potentsiallar tahlilidan foydalanib aniqlang:

10.18-rasm.

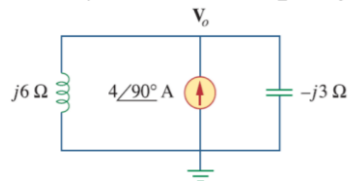

- A)  $-24 V$ .  
 B)  $-8 V$ .  
 C)  $8 V$ .  
 D)  $24 V$ .

10.4. 10.19-rasmda keltirilgan zanjirdagi  $i(t)$  ni aniqlang:

10.19-rasm.

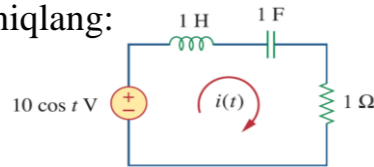

- A)  $10 \cos t A$ .  
 B)  $10 \sin t A$ .  
 C)  $5 \cos t A$ .  
 D)  $5 \sin t A$ .  
 E)  $4,472 \cos(t - 63,43^\circ) A$ .

10.5. 10.20-rasmdagi zanjirga qarang va ikkita manba bir xil chastotaga ega emasligiga e'tibor bering. Tok kuchi  $i_x(t)$  ni quyidagilar orqali olish mumkin:

10.20-rasm.

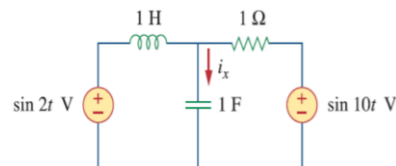

- A) manba transformatsiyasi.  
 B) superpozitsiya teoremasi.  
 C) Pspice.

10.6. 10.21-rasmda keltirilgan zanjirning  $a-b$  terminallaridagi Tevening impedansini aniqlang:

- A)  $1 \Omega$ .  
 B)  $0,5 - j0,5 \Omega$ .  
 C)  $0,5 + j0,5 \Omega$ .  
 D)  $1 + j2 \Omega$ .  
 E)  $1 - j2 \Omega$ .

10.21-rasm.

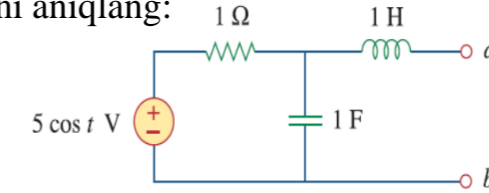

10.7. 10.21-rasmda keltirilgan zanjirning  $a-b$  terminallaridagi Tevening kuchlanishini aniqlang:

- A)  $3,535 \angle -45^\circ V$ .  
 C)  $7,071 \angle -45^\circ V$ .

- B)  $3,535 \angle 45^\circ V$ .  
 D)  $7,071 \angle 45^\circ V$ .

10.8. 10.22-rasmda keltirilgan zanjirning  $a-b$  terminallaridagi Norton ekvivalent impedansini aniqlang:

- A)  $-4j \Omega$ .

- B)  $-j2 \Omega$ .

- C)  $j2 \Omega$ .

- D)  $j4 \Omega$ .

10.22-rasm.

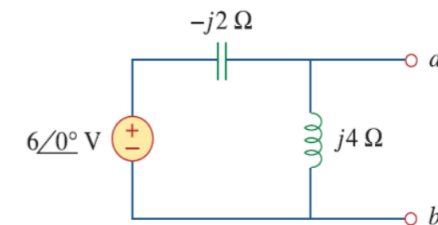

10.9. 10.22-rasmda keltirilgan zanjirning  $a-b$  terminallaridagi Norton tok kuchini aniqlang:

- A)  $1 \angle 0^\circ A$ .

- B)  $1,5 \angle -90^\circ A$ .

- C)  $1,5 \angle 90^\circ A$ .

- D)  $3 \angle 90^\circ A$ .

10.10. PSpice turli chastotali ikkita mustaqil manbaga ega bo'lgan zanjirni boshqarishi mumkin.

- A) to'g'ri.

- B) noto'g'ri.



*E'TIBORINGIZ  
UCHUN  
RAHMAT!!!*