

# VEHICLES CONSTRUCTION

## AVTOMOBILLAR KONSTRUKSIYASI

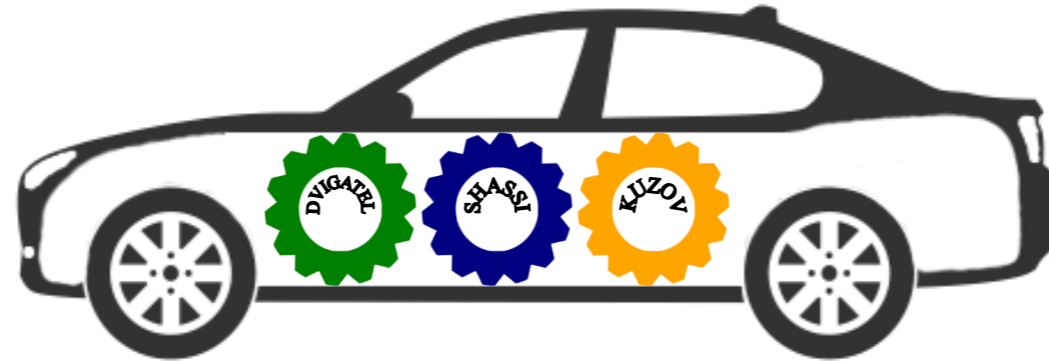

### 3<sup>rd</sup> Topic: Crank-drive mechanism

(3-Mavzu: Krivoship-shatunli mexanizm)

#### Part 2

Associate Professor: Yusupov Sarvarbek

## 3-Mavzu: Krivoship-shatunli mexanizm

(3<sup>rd</sup> Topic: Crank-drive mechanism)

### O‘quv rejasi:

- 3.1. KShMning vazifasi va tuzilishi.
- 3.2. KShMning asosiy qismlari.
- 3.3. Silindrlar bloki, silindrlar blokining kallagi va gilza konstruksiyasi.
- 3.4. Shatun va shatun podshipniklarining konstruksiyasi.**
- 3.5. Porshen, porshen halqalari va porshen barmog‘ining konstruksiyasi.**
- 3.6. Tirsakli val va maxovikning konstruksiyasi.**

### 3.4. Shatun va shatun podshipniklarining konstruksiyasi.

Shatun porshenni porshen barmog‘i orqali tirsakli valning shatun bo‘yni bilan birlashtiradi va **ish takti paytida porshendan tirsakli valga**, yordamchi (**kiritish**, **siqish** va **chiqarish**) taktlarida esa tirsakli valdan porshenga harakat uzatadi.

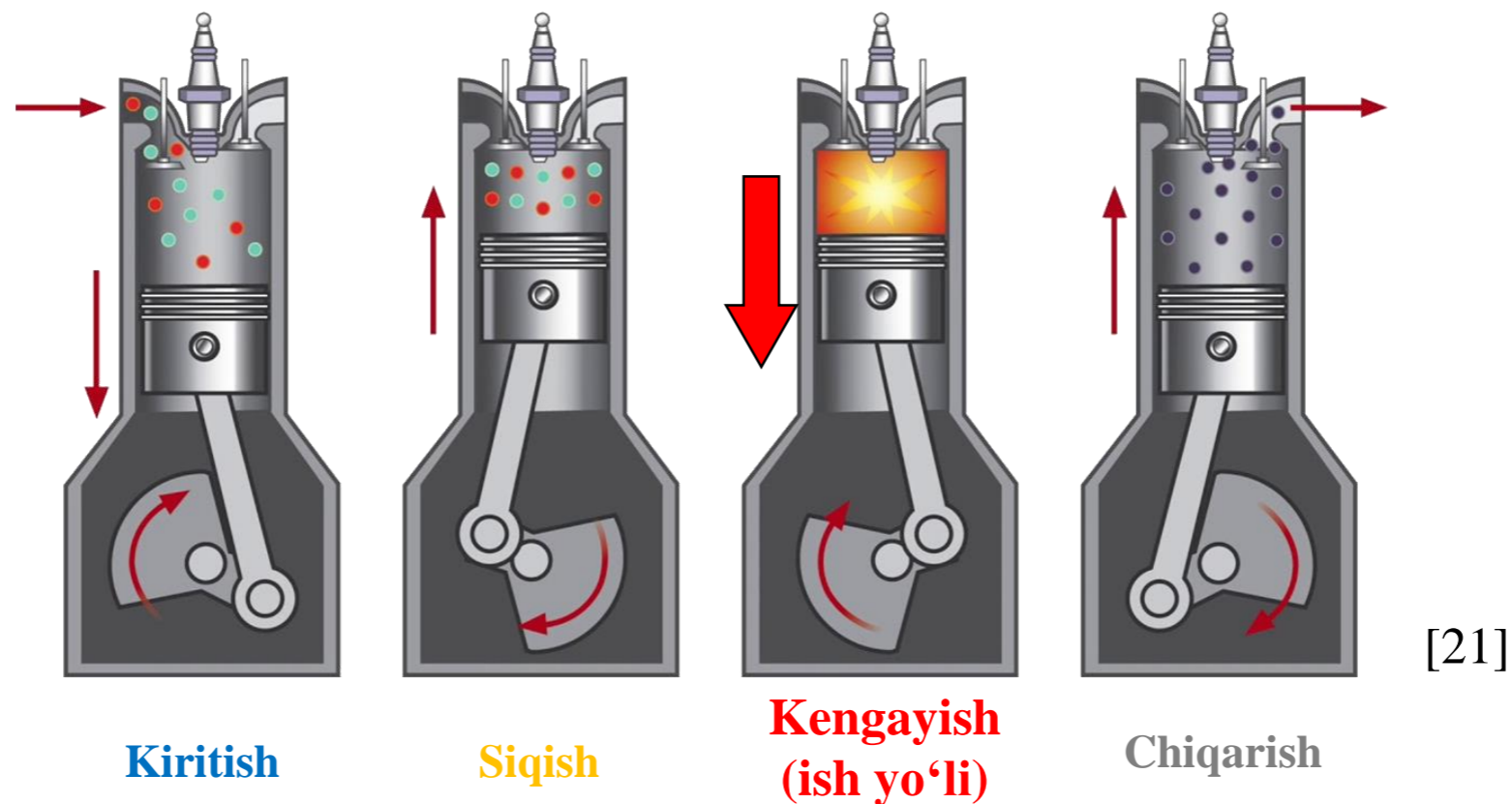

Demak, shatun yordamida porshenning tog‘ri chiziqli ilgari lama – qaytma harakati

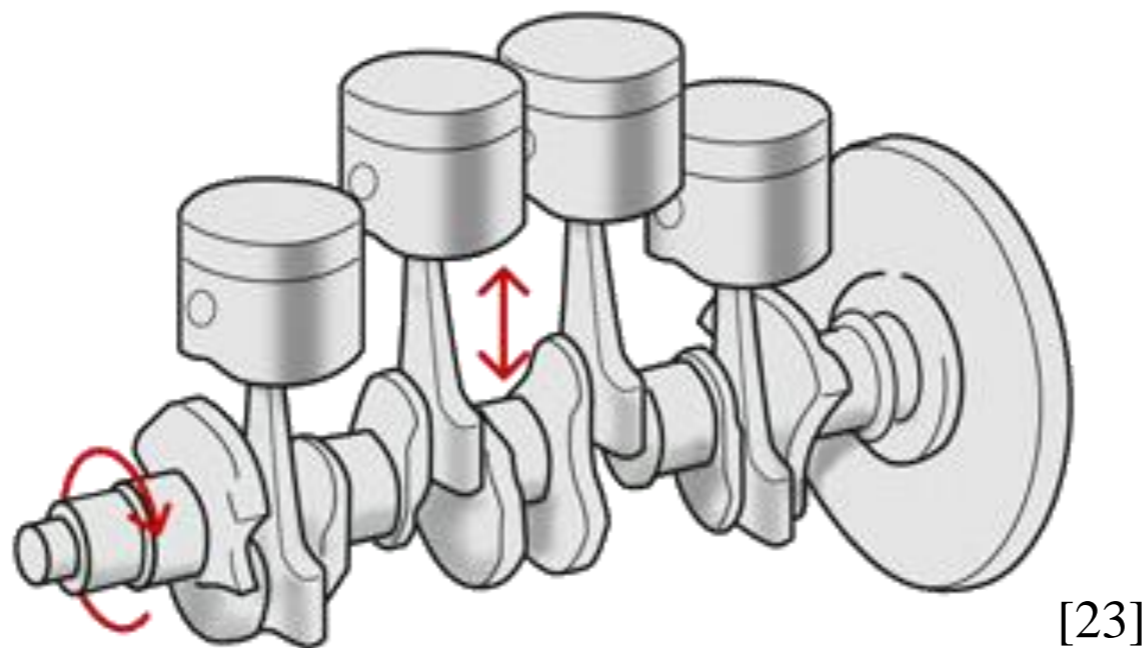

tirsakli valning aylanma harakatiga o‘zgartirib beradi.

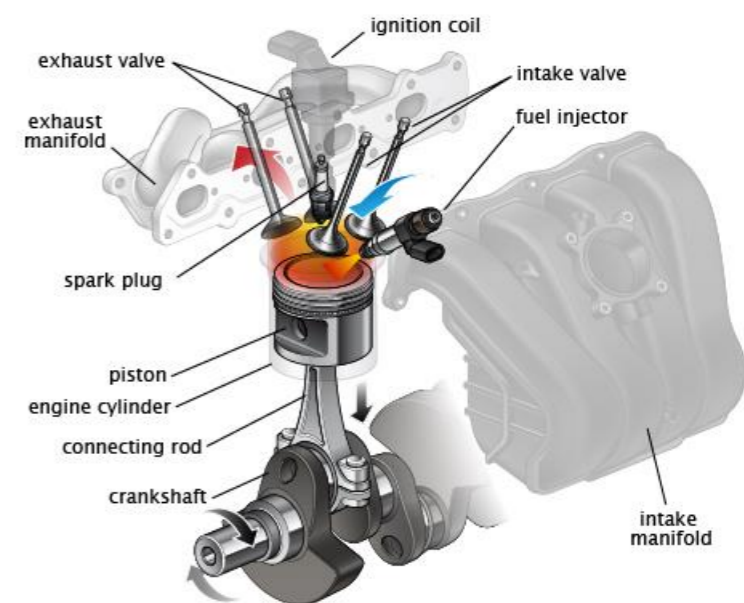
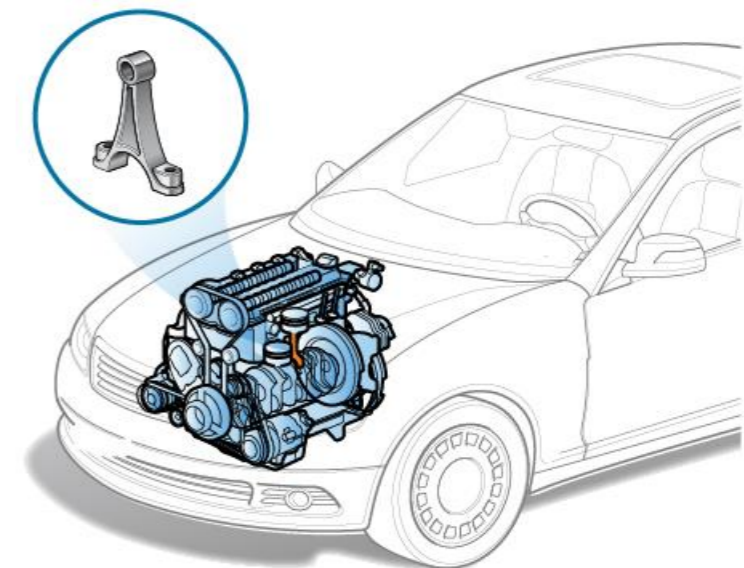

Image courtesy of ClearMechanic.com

Shatun **mustahkam**, **puxta**, **yeyilishga chidamli** va **inersiya kuchlarini** kamaytirish uchun vazni deyarli **kichik bo‘lishi lozim**.

Shatunlar **yuqori sifatli uglerodli** yoki **ligerlanagan po‘latdan** (40G, 40G2, 40X, 4XN, 40XGT) shtamplash usuli bilan tayyorlanadi va **mexanik ishlov berib aniqligi**, **termik ishlov berib** esa **puxtaligi oshiriladi**.



[25]

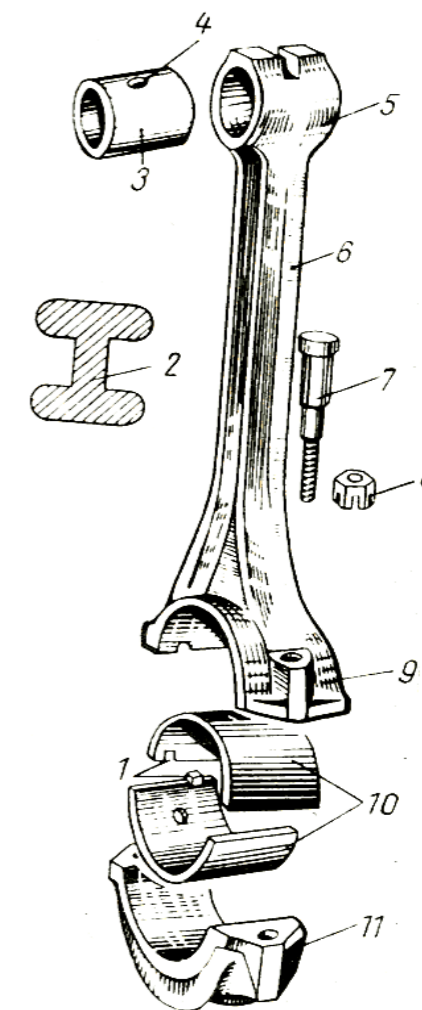

[24]

Shatun va unga bevosita o‘rnatilgan detalar guruhi.

Shatunning pastki kallagi ishlaydigan og‘ir sharoit **juda katta ishqalanish kuchlarini** vujudga keltiradi.

**Tirsakli valning yeyilishini kamaytirish** va **shatunning ish muddatini oshirish** maqsadida shatunning pastki kallagiga yupqa sust ishqalanuvchi qotishmadan quyilgan **vkladishlar** qo‘yiladi.

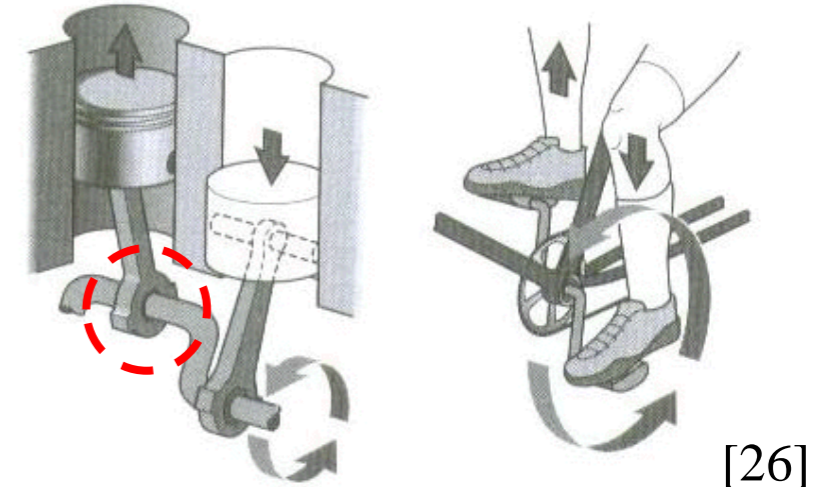

[26]

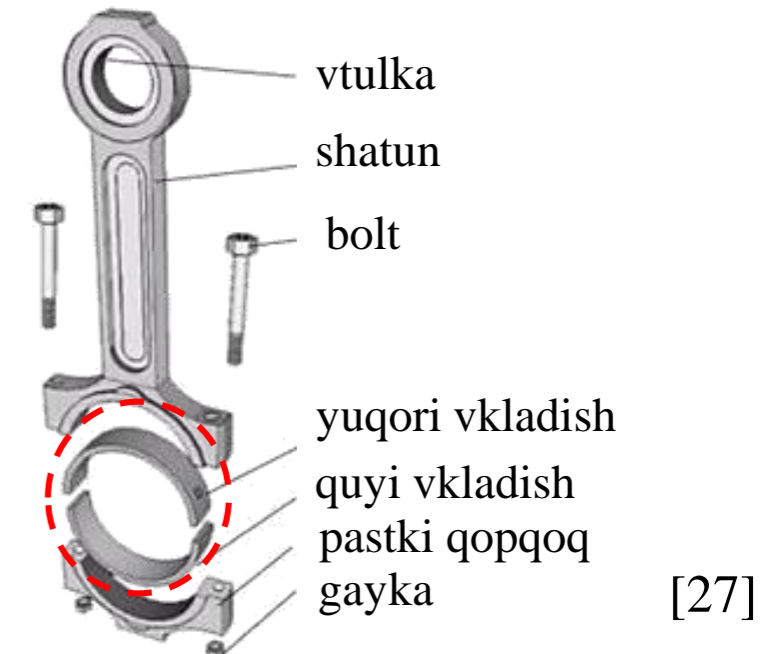

[27]

## Sust ishqalanuvchi qotishmalarga quyidagi talablar qo'yiladi:

- po'lat bilan ilashmalanib ishlaganda ishqalanish koeffitsienti kichik;
- kam yediriladigan;
- issiqlikni yaxshi o'tkazadigan va arzon bo'lishi kerak;
- ishqalanuvchi yuzalarning bir tekis moylana olishini ta'minlay olishi kerak.



[28]

### 3.5. Porshen, porshen halqalari va porshen barmog‘ining konstruksiyasi.

Dvigatelda sodir bo‘ladigan ish siklining barcha jarayonlari *porshen* vositasida bajariladi.

Ish sharoitida, ayniqsa **siqish** va **ish yo‘li** taktlarida yuqori bosimga va haroratga ega bo‘lgan gazlar ta‘sirida **porshen qiziydi** va **yediriladi**.

Unga o‘zgaruvchan inersiya kuchlari ta‘sir etadi.

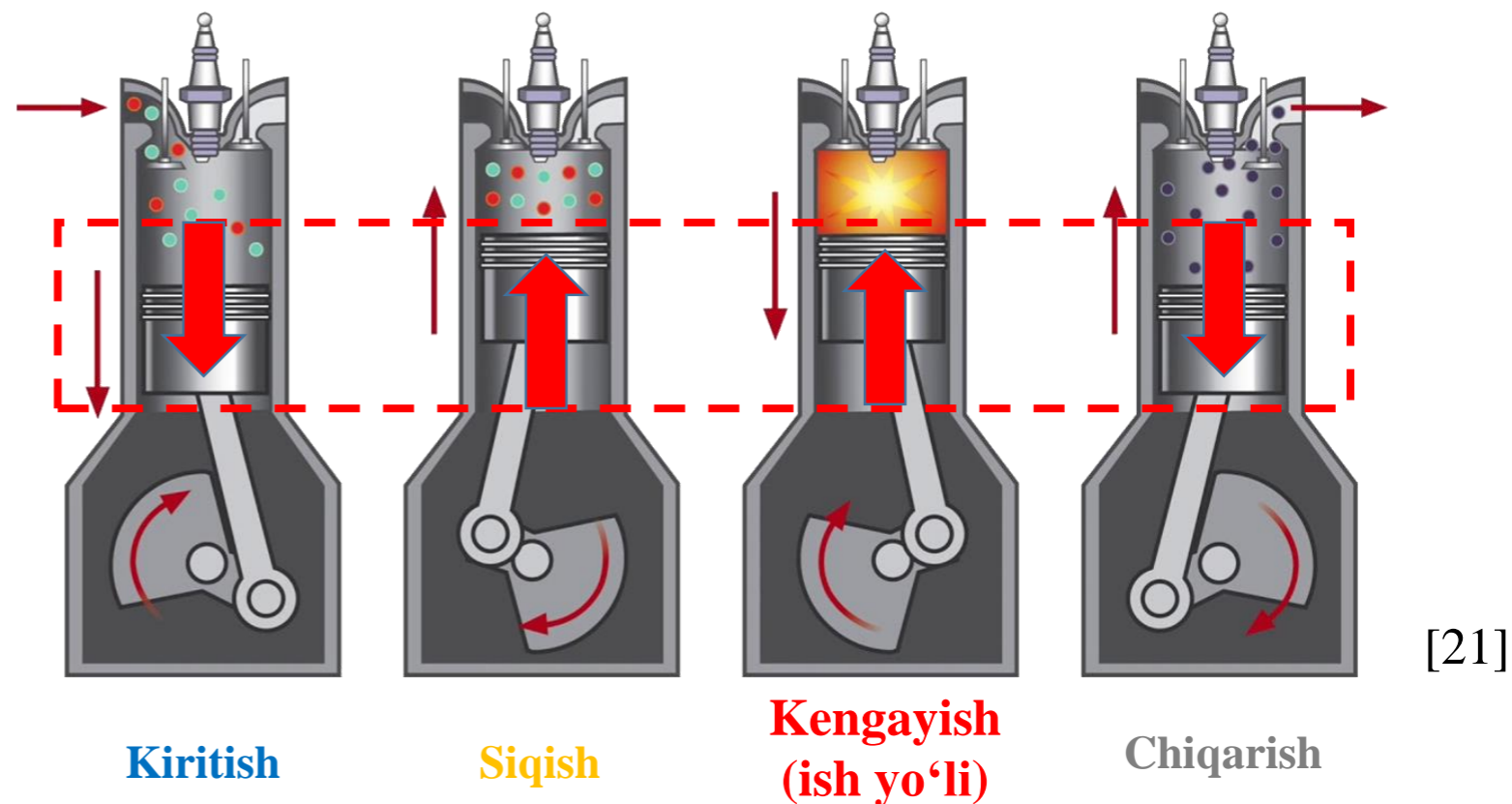

[21]

Shu sababli porshen tayyorlanadigan material  
quyidagi talablarni qanoatlantirishi:

- *Issiqlik o'tkazuvchi;*
- *Yedirilishga chidamli;*
- *Mustahkam;*
- *Yengil.*

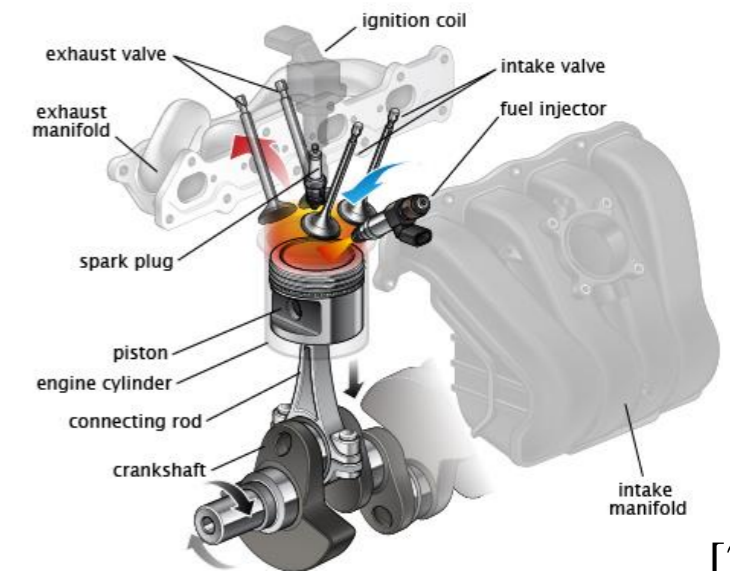
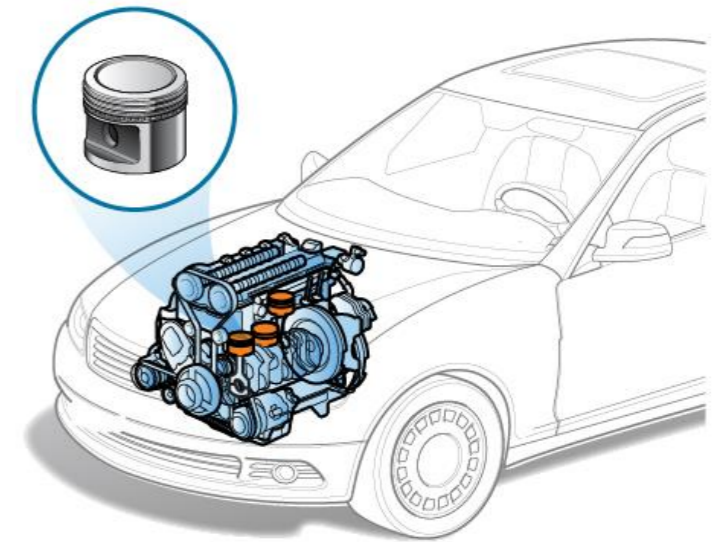

[29]

Image courtesy of ClearMechanic.com

# Porshening konstruksiyasi

Porshen alyuminiy qotishmasidan yoki cho‘yandan yasalishi mumkin.

**AL25, AL30**

**yoki**

**AK10, M2H**

halqa ariqchalari -

bo‘rtiqlik qismi -

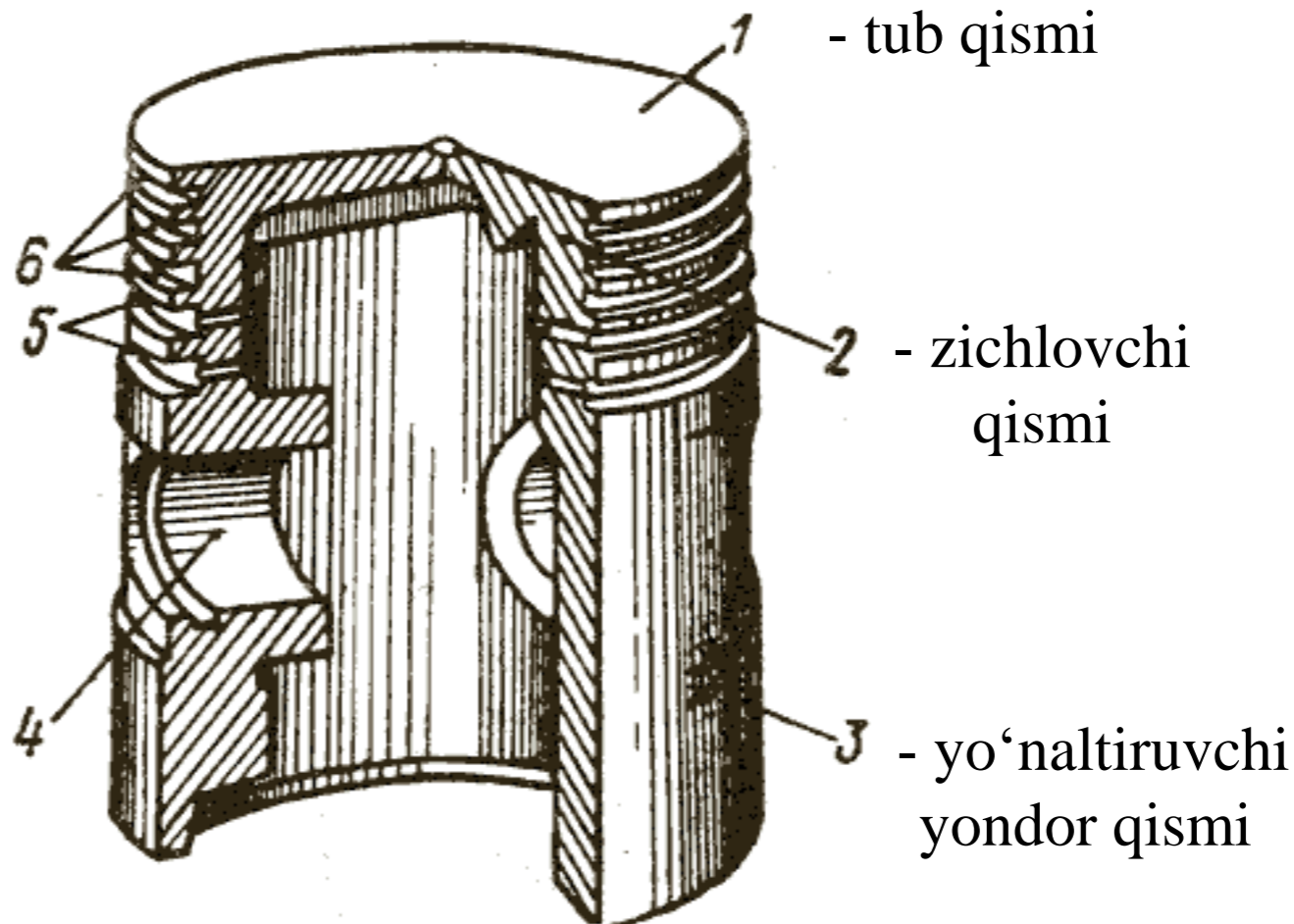

[30]

Dizellarga qo'yiladigan porshenlarning tubi ichiga botiq qabariq

yoki murakkab shaklda tayyorlanadi.

Porshenning qanday shaklda yasalishi **siqish bo'linmasining shakli**, **gaz oqimining yo'nalishi** va **klapanlarning joylashuviga bog'liq**.

Kremniy elementi ko'p (22%) bo'lgan aluminiyli qotishmadan tayyorlangan porshenlarning issiqlikdan kengayish koeffitsiyenti kichik bo'ladi.



[31]



[33]



[32]

Porshening yuqorigi qismi, yondoriga qaraganda **ko'proq qiziydi**

va kengayadi.

Dvigatel →

porshen →

silindr →

**issiqlik tirqish**

Porshen balandligi bo'yicha **konus** shaklida bo'ladi.

$$A < B$$

0,5...0,7 mm

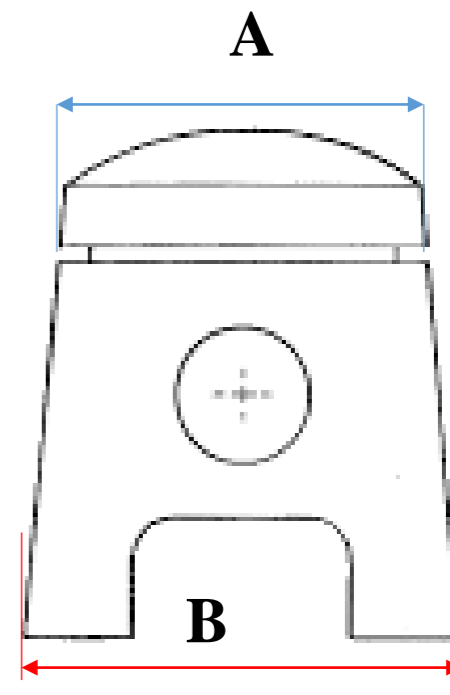

Porshen yubkasining ko'ndalang kesimi **oval**

shaklida tayyorlanib, katta o'qi porshen barmog'iga perpendikulyar tomonga qaratilgan bo'ladi.

$$C < D$$

0,3...0,5 mm

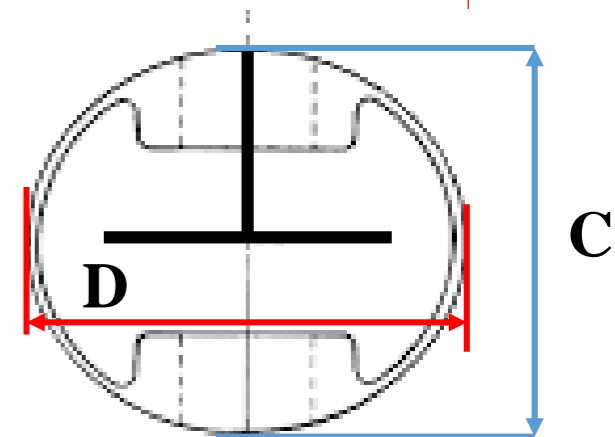

[34]

Shu sababli porshen qiziganda silindr ichida juda kichik tirqish (**0,05-0,10 mm**) bilan ham qadalmasdan harakatlanadi.

Porshen silindrda ishqalanib, uning ishchi yuzasiga tez moslashishi uchun uning tashqi devoriga yupqa qalinlikda **qalay** qoplanadi.



[35]



## Porshen halqalarining konstruksiyasi

Porshen halqalari **yuqori harorati** va **bosimga** ega bo‘lgan gazlar,

o‘zgaruvchan qiymatga ega bo‘lgan **inersiya kuchlari** ta’sir etadigan og‘ir ish sharoitida ishlaydi.

Porshen halqalari **maxsus cho‘yandan**, ayrim hollarda esa **po‘latdan** ham tayyorlanadi.

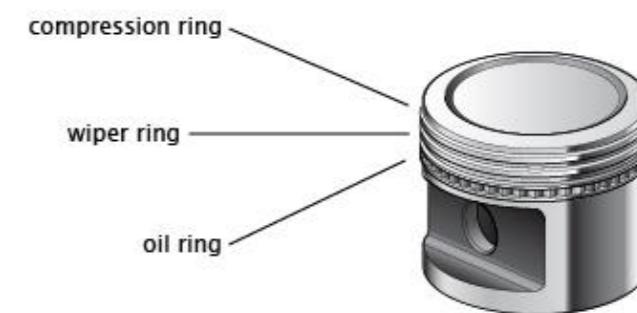
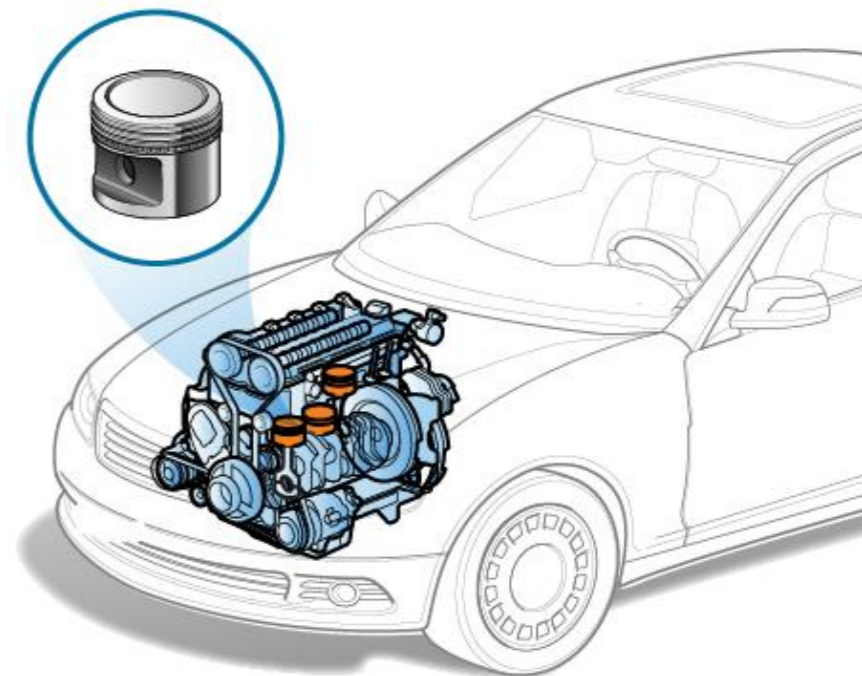
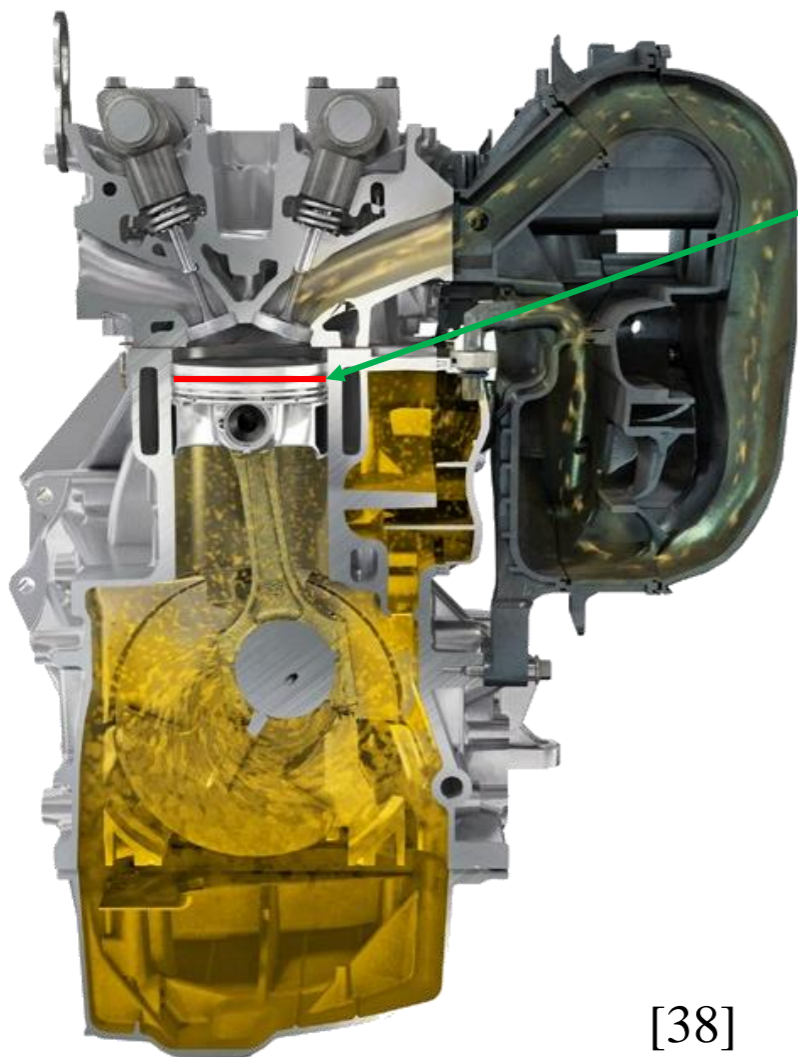

Image courtesy of ClearMechanic.com

[36]

Porshen halqalari vazifalariga ko'ra:



[38]

**1. Kompresion;**

**2. Moy sidirgichli.**

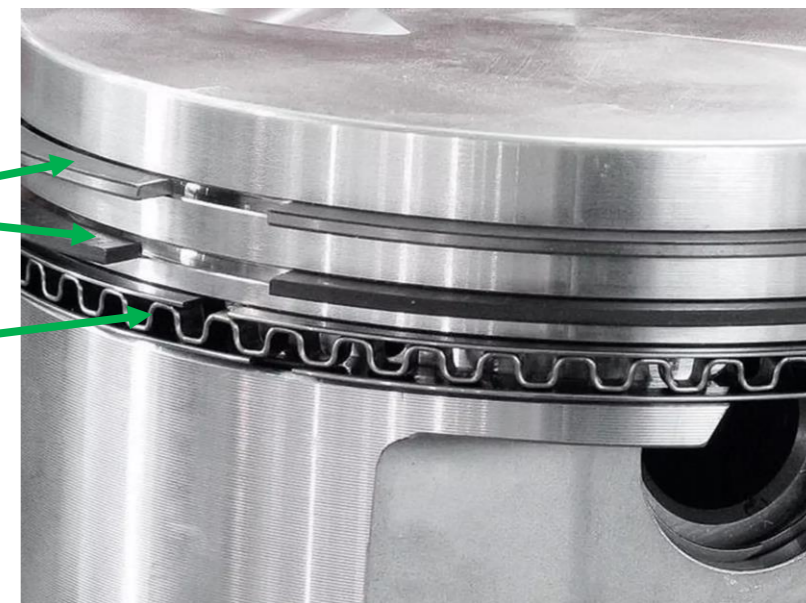

[37]

**Kompresion halqalari** silindr va porshen oraliqlarini jipslashtiradi hamda silindrda hosil bo'lgan **gazlarni karterga, moyni esa yonish kamerasiga o'tishdan saqlaydi.**

**Kompression halqalarning yeyilishga chidamliligi va ishlash muddatini oshirish maqsadida** ularning tashqarisiga **g'ovak xrom qoplanadi,**

xrom qatlami ularning ishlovchi **yuzalarining qattiqligini oshiradi,** natijada halqalarning **yeyilishi kamayadi,**

xrom qatlamidagi g'ovakchalar silindr yuzasidan moyni o'ziga singdirib, yubqa pardasini hosil qiladi, **bu esa silindr yuzasining yeyilishini kamaytiradi.**

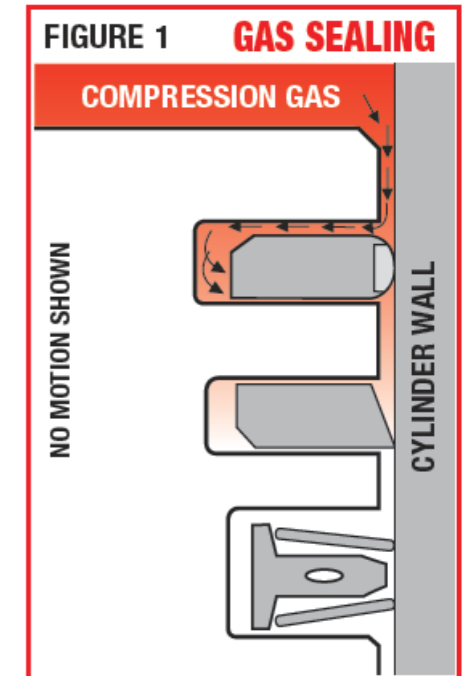

[39]

Bundan tashqari, **porshen kallagidan issiqlikni** silindr devorlari orqali **sovutuvchi muhitga tarqatadi.**

**Moy sidirgich halqalar** silindr devoridagi ortiqcha moylarni sidirib, ularni yonish kamerasiga o'tishini cheklab turadi.

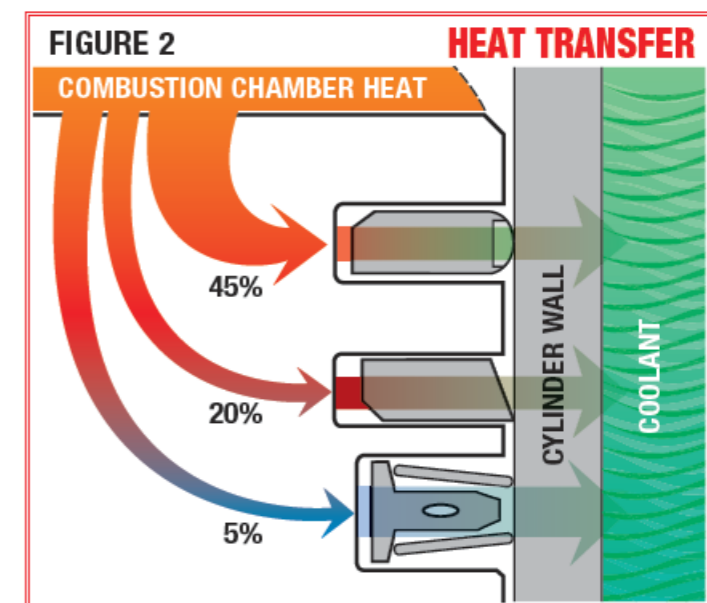

RINGS TRANSFER 70% OF COMBUSTION CHAMBER HEAT INTO THE CYLINDER WALL  
(All figures shown are close approximations)

[40]

# Moy sidirgich halqalar konstruksiyasi bo'yicha:

## Yaxlit



drenaj yoki

[41]

radial teshikchalar

ikkita yupqa  
disksimon halqa

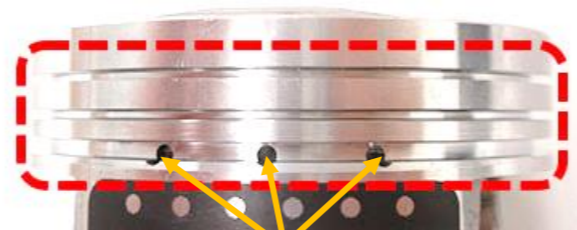

[43]

## Yig'mali

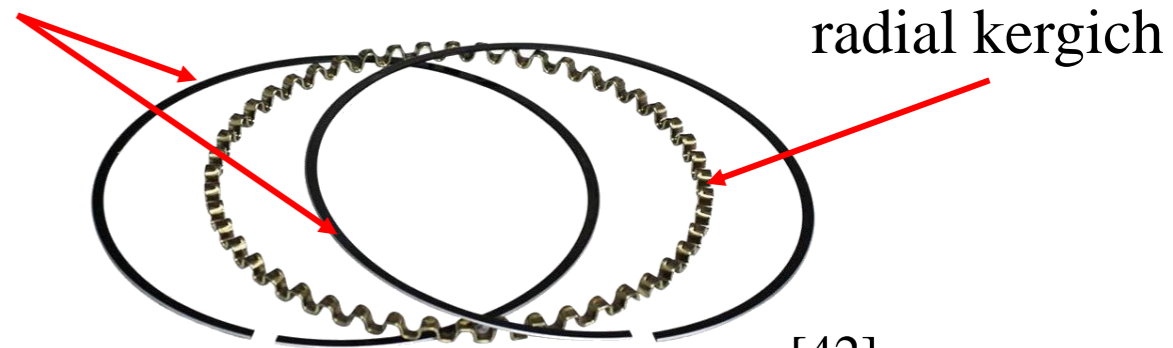

[42]

radial kergich

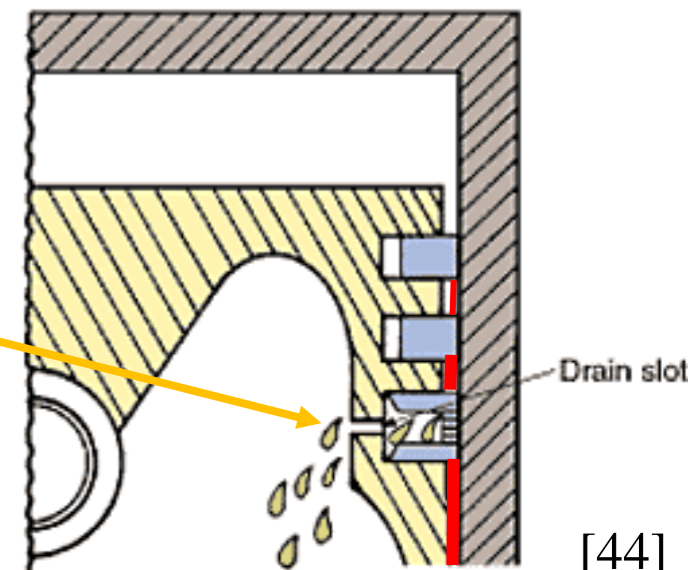

[44]

Bunday halqalar silindr yuzasiga tez moslashishga va yaxshi elastik xususiyatlarga ega, shuning uchun ular silindr devorlariga tez va yaxshi zichlashadi.

Halqadagi maxsus kesik qulf deb ataladi.

Bu kesik halqaning ishlashi jarayonida elastiklik xususiyatini oshiradi va uning silindrda qadalib qolmasligini ta'minlaydi.

Halqalar silindrga o'rnatilganida ularning qulfidagi tirqish **0,2-0,5 mm** oralig'ida bo'ladi.

Halqalardagi qulflarning shakli:

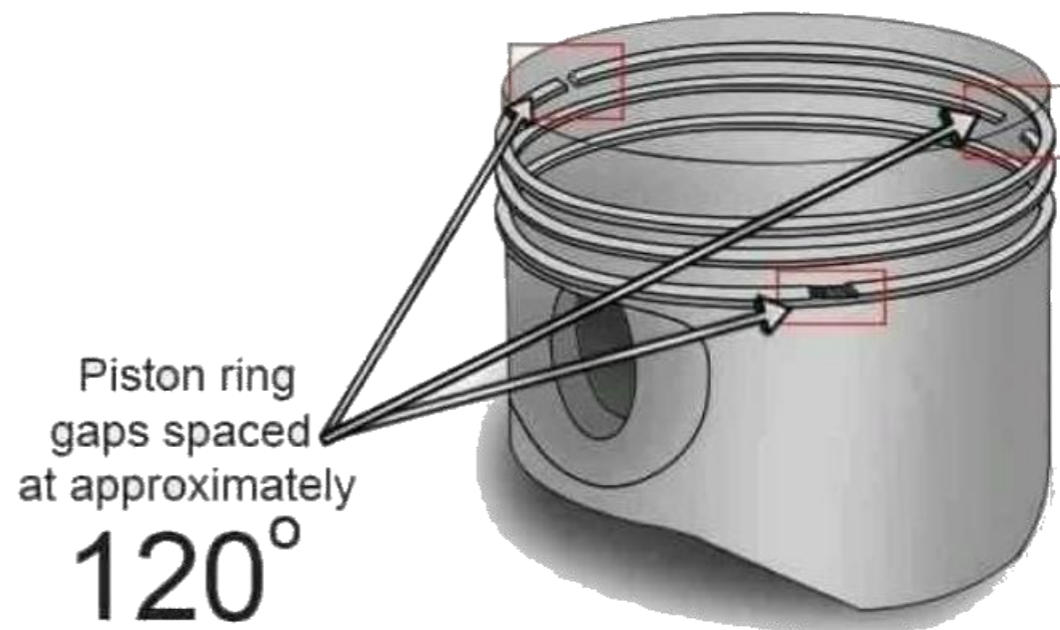
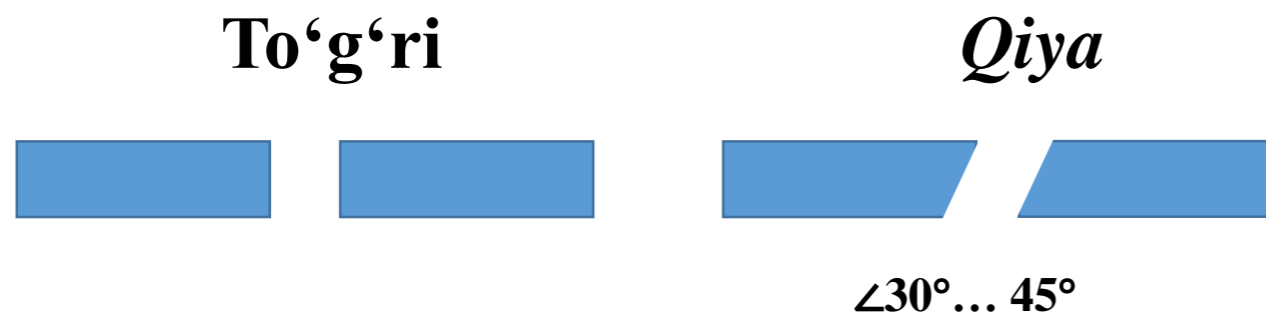

[45]

# Porshen barmog'ining konstruksiyasi

Porshen barmog'i bilan shatun sharnir ravishda tutashtiriladi.

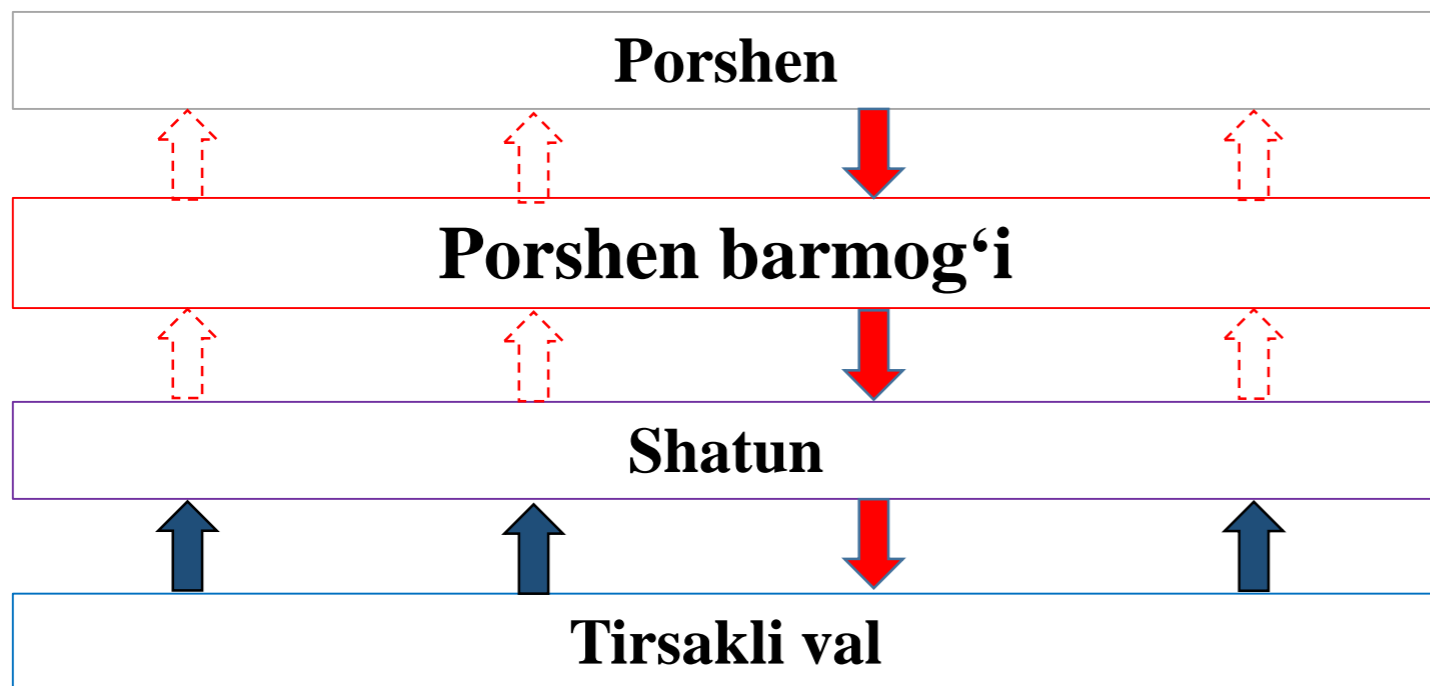

**Kiritish**

**Siqish**

**Kengayish  
(ish yo'li)**

**Chiqarish**

Porshen barmog'i porshen bilan birga tezlanish va yo'nalishini o'zgartirib harakatlanadi.

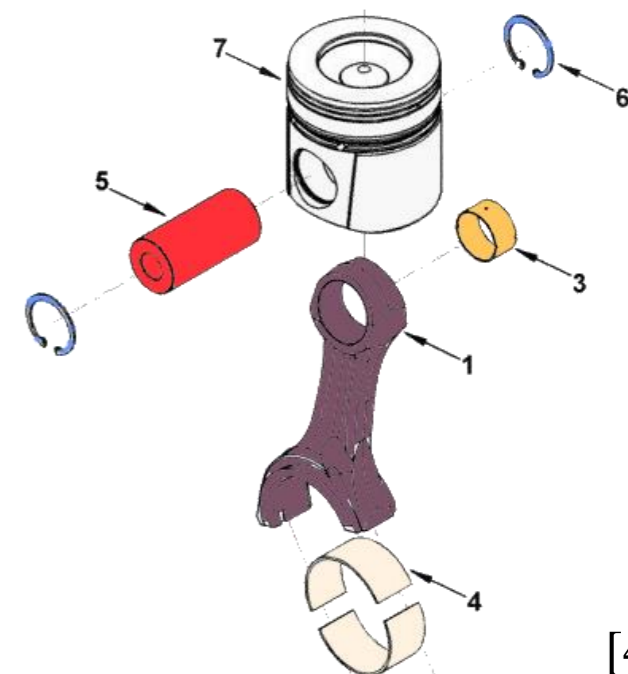

[46]

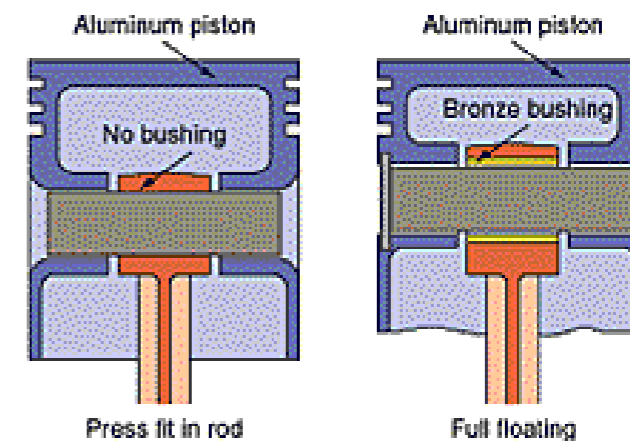

[47]

Shuning uchun u og‘ir bo‘lmasligi kerak, aks holda mexanizmga salbiy ta‘sir etuvchi inersiya kuchlarining miqdori ortib ketadi.

Porshen barmog‘i shatun kallagida va porshen bo‘rtiqli tuynugida ishqalanish natijasida qiziydi.

➤ **Puxta;**

➤ **Mustahkam;**

➤ **Yeyilishga chidamli;**

➤ **Kichik vaznli.**

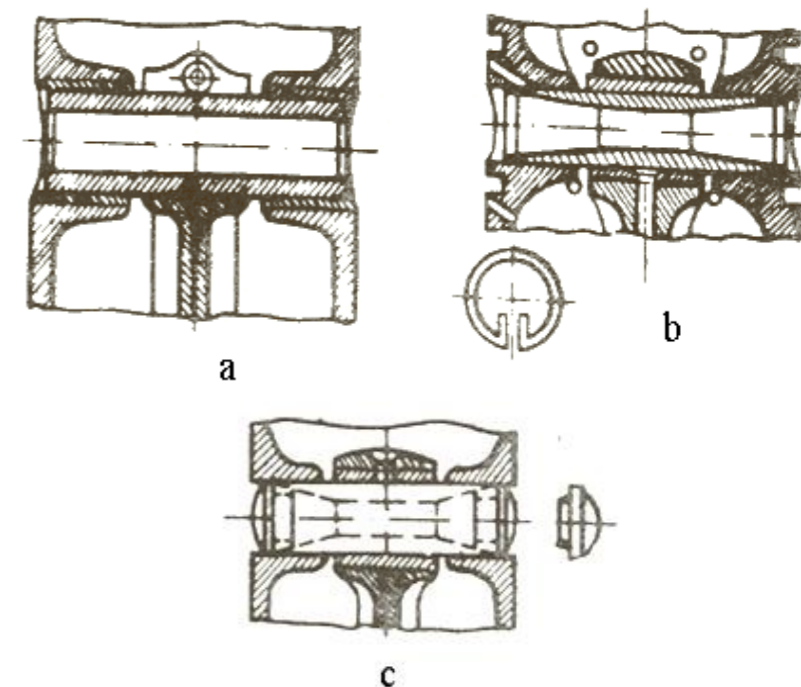

[48]

Porshen barmoqlari va ularning mahkamlanish turlari.  
 a – porshen barmog‘i shatunning yuqori kallagida qattiq mahkamlangan, b, c – o‘z o‘qi atrofida siljuvchi “erkin” barmoq.

# Silindr porshen guruhi detallari

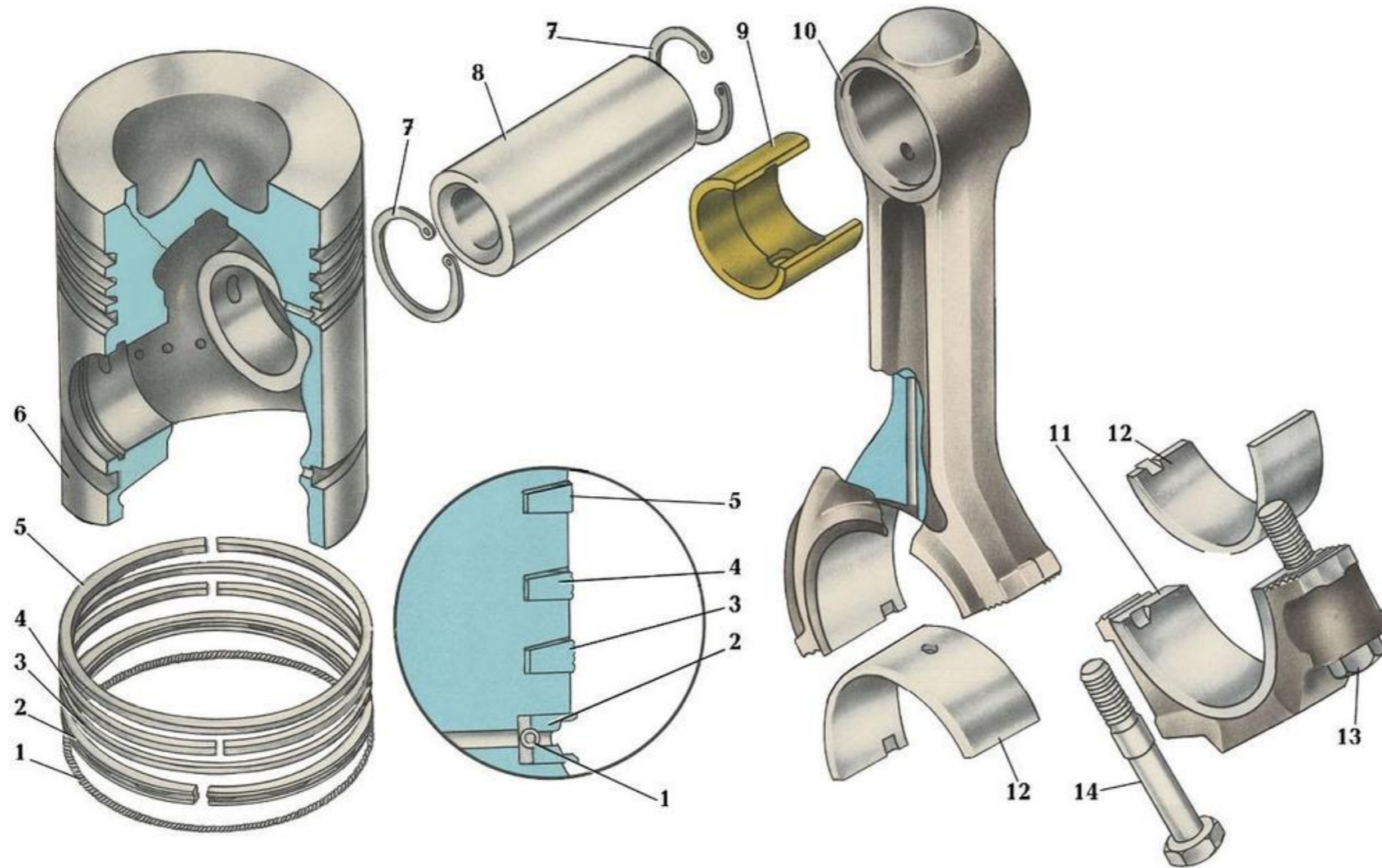

1. Расширитель маслосъемного кольца.
2. Кольцо поршневое маслосъемное.
3. Кольцо компрессионное, третье.
4. Кольцо компрессионное, второе.
5. Кольцо компрессионное, верхнее.
6. Поршень.
7. Кольцо стопорное.
8. Палец поршневой.
9. Втулка шатуна.
10. Шатун.
11. Крышка шатуна.
12. Вкладыш нижней головки шатуна.
13. Болт крышки шатуна, короткий.
14. Болт крышки шатуна, длинный.

[49]

## 3.6. Tirsakli val va maxovikning konstruksiyasi.

Tirsakli val porshen orqali shatundan kelayotgan kuchni qabul qiladi va uni aylanma harakatga o‘zgartirib beradi.

Tirsakli valda hosil bo‘lgan aylanma harakatning oz qismi dvigatel mexanizmi va qurilmalarini yurgizish uchun sarf qilinadi.

Qolgan asosiy qismi esa kuch uzatmalari vositasida g‘ildiraklarga uzatiladi.

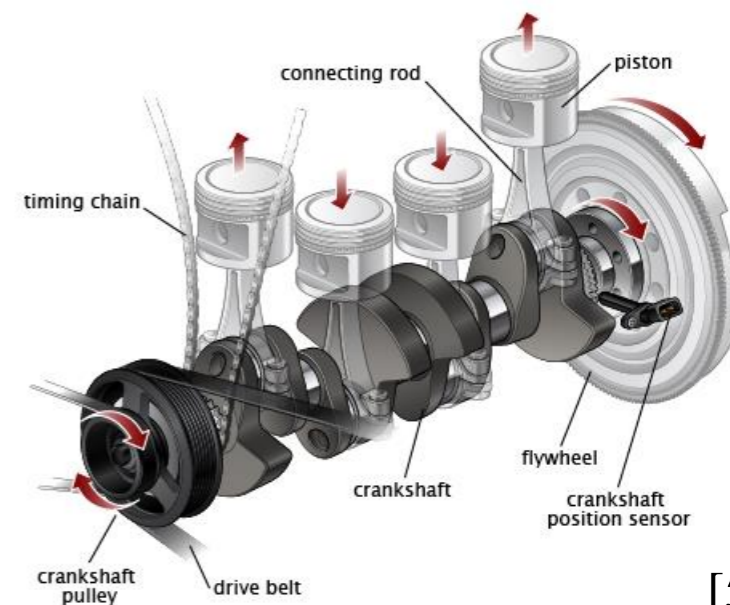
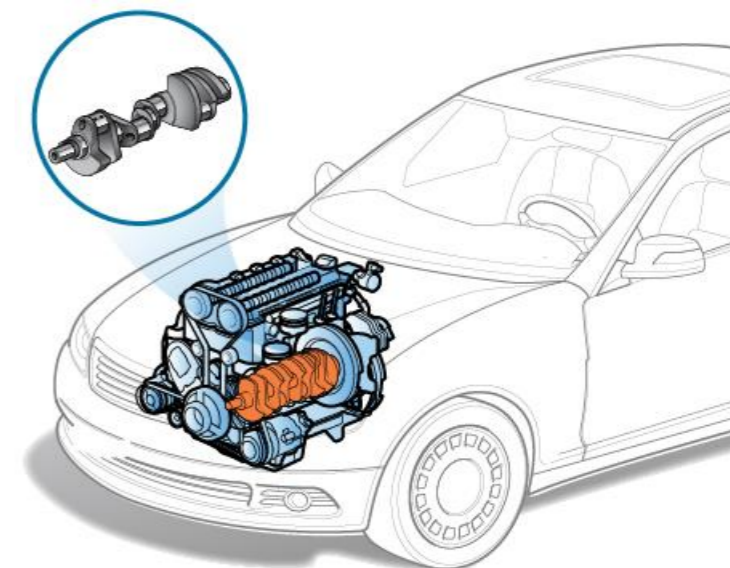

[50]

Image courtesy of ClearMechanic.com

# Tirsakli val

➤ Eguvchi; ➤ Burovchi; ➤ Siquvchi; ➤ Cho‘zuvchi. ← F

Shuning uchun tirsakli val ana shu kuchlarga bardosh beradigan mustahkam va qattiq materialdan tayyorlanishi kerak.

Bundan tashqari, uning shatun va o‘zak bo‘yinlari yeyilishga chidamli bo‘lishi kerak.

## O‘zak podshipnigi:

- benzinli dvigatellarda 1,3-1,8 mm
- dizellarda 2,0-3,6 mm

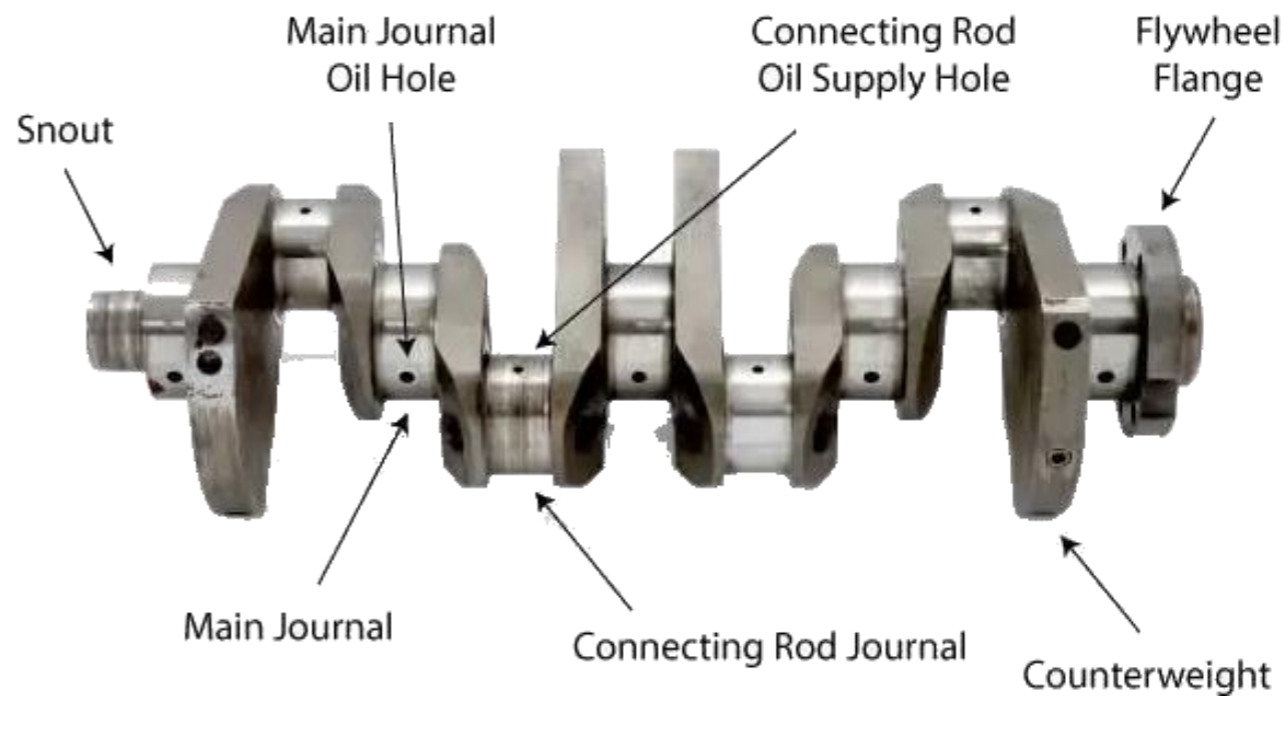

[51]

Qalay-aluminiyli qotishmalardan (25=30% qalay, qolgani aluminiy)

Tirsakli valni shtamplash usuli bilan yuqori uglerodli po‘latdan yoki magniy bilan boyitilgan legirlangan cho‘yandan tayyorlanadi va bo‘yinlariga termik ishlov beriladi, keyin jilvirlanadi va jilovlanadi.



[52]



## Tirsakli valning shakli:

KShM ning joylashuviga;

silindrlarining ish tartibiga.

silindrlarning soniga;

**Silindrlari bir qator joylashgan dvigatellarda:** shatun bo'yinlari = silindrlar soni

**V simon dvigatellarida:** silindrlar sonining yarmiga teng bo'ladi.

Tirsakli val o'zak bo'yinlarining soni ko'p hollarda shatun bo'yinlari sonidan bittaga ortiq bo'ladi.

Bunday vallar - **to'la tayanchli** tirsakli vallar deb ataladi.

## Maxovik tirsakli valning notekis aylanishini kamaytiradi.

U ish yo‘li taktida yiqqan energiyasi hisobiga, yordamchi taktlar bajarilishida tirsakli valni aylantiradi va krivoshipshatunli mexanizm detallarining chetki nuqtalaridan o‘tishida yordam beradi.

Shuningdek yig‘ilgan energiya hisobiga dvigatelning starter bilan o‘t oldirilishini va avtomobilning joyidan qo‘zg‘alishini osonlashtiradi.

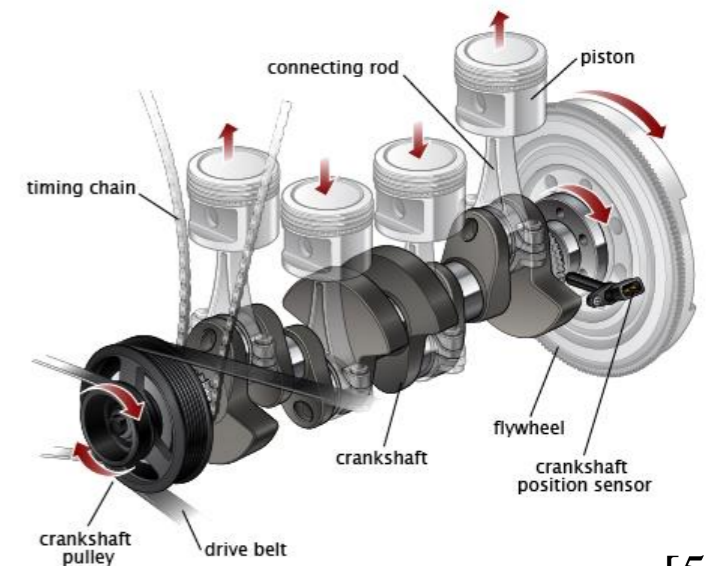
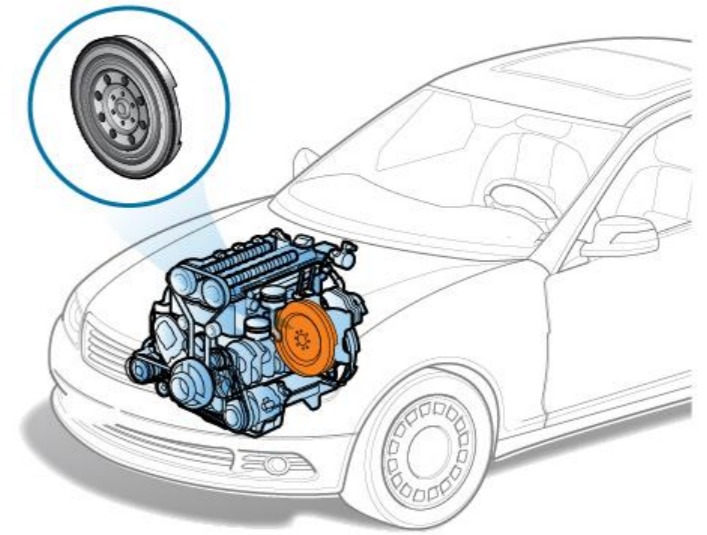

[53]

Image courtesy of ClearMechanic.com

Maxovik choʻyandan quyiladi va tirsakli valning orqa qismiga boltlar bilan mahkamlanadi.

Maxovik tirsakli val bilan birgalikda yaxshilab muvozanatlanadi.

Dvigatelni starter bilan yurgazish uchun maxovikka tishli gardish presslab oʻtqaziladi.

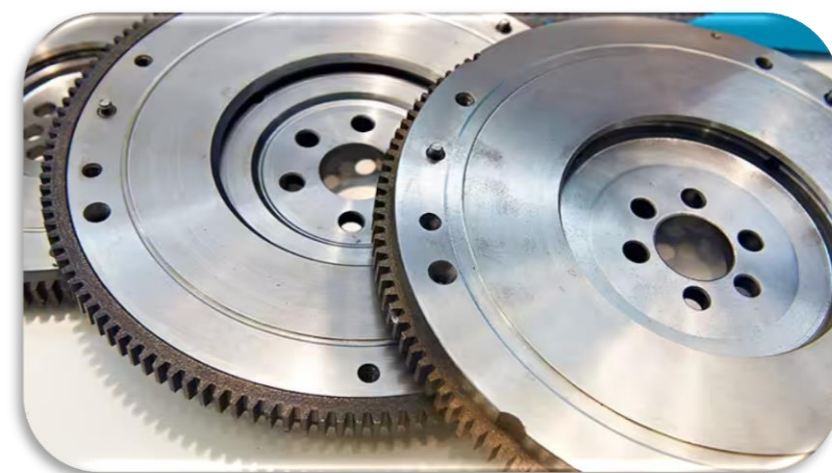
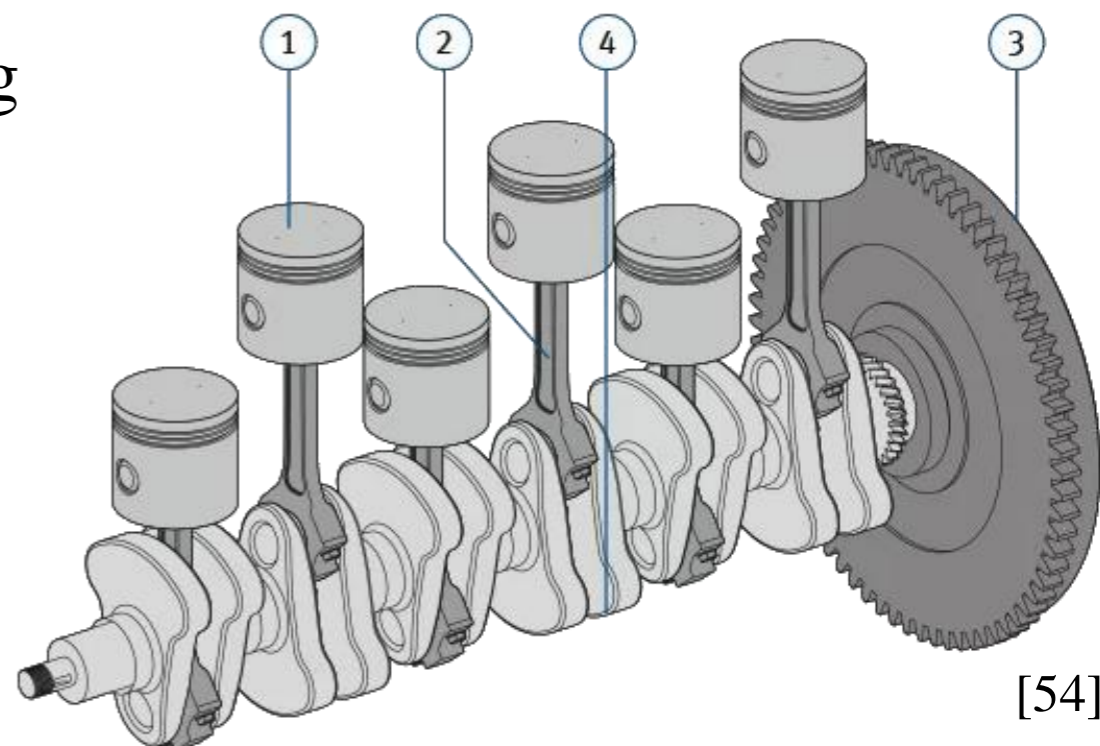



# FOYDALANILGAN ADABIYOTLAR

21. What Does This Thing Do: Pistons. [Online Image] [Accessed on 30 November 2017]. <https://i.ytimg.com/vi/RV1xWCpBEr8/maxresdefault.jpg>
22. Signs of a Bad Connecting Rod. By Stephen Fogel. [Online Image] [Accessed on 23 March 2020]. [https://repairpal.com/stored\\_images/65179](https://repairpal.com/stored_images/65179)
23. Коленчатый вал: то, что делает двигатель двигателем. [Online Image] [Accessed on 2 September 2013]. <https://www.autoopt.ru/upload/iblock/01d/kolenval.jpg>
24. Yusupov S. "Avtomobillar konstruksiyasi" 1-qism. O'quv-uslubiy majmua. A.: AndMI. 2019 yil, -b. 52 (493).
25. Шатун, втулка шатуна. [Online Image] [Accessed in 2007]. <https://www.zipteh.ru/uploads/filestorage/menu/elements/t1033.jpg?v=1672137035>
26. The Automobile's Engine. [Online Image] [Accessed in 2010]. <https://www.angelfire.com/ia3/autocare/images/pistonsrodpedalsbike.gif>
27. Шатун двигателя в вопросах и ответах. [Online Image] [Accessed on 26 February 2017]. [https://howcarworks.ru/sites/default/files/styles/article\\_image\\_max\\_page\\_width\\_resize\\_670/public/img/2017-02-25\\_172926.jpg?itok=Oj8LZcvV](https://howcarworks.ru/sites/default/files/styles/article_image_max_page_width_resize_670/public/img/2017-02-25_172926.jpg?itok=Oj8LZcvV)
28. Вкладыши шатуна +0,5 мм (186F). [Online Image] [Accessed in 2023]. <https://motoblok-1.com.ua/image/cache/catalog/vkladishi-700x700.jpg>
29. Symptoms of a Bad Piston. By Stephen Fogel. [Online Image] [Accessed on 3 October 2019]. [https://repairpal.com/stored\\_images/65178](https://repairpal.com/stored_images/65178)
30. Yusupov S. "Avtomobillar konstruksiyasi" 1-qism. O'quv-uslubiy majmua. A.: AndMI. 2019 yil, -b. 53 (493).
31. Engine advancements subject of Summit panel. By Mike Brezonick. [Online Image] [Accessed on 12 October 2021]. <https://www.dieselprogress.com/Images/1140xany/20211012-165958-EYB-Cover.jpg>
32. The Demands on Diesel Pistons and Sleeves. By Larry Carley. [Online Image] [Accessed on 8 August 2014]. [https://marvel-b1-cdn.bc0a.com/f00000000270523/s19529.pcdn.co/wp-content/uploads/fed\\_mogul\\_steel\\_diesel\\_piston-web-300x225.jpg](https://marvel-b1-cdn.bc0a.com/f00000000270523/s19529.pcdn.co/wp-content/uploads/fed_mogul_steel_diesel_piston-web-300x225.jpg)
33. Keith Black Pistons. [Online Image] [Accessed in 2023]. <https://www.southeastr.net/images/kb%20pistons.jpeg>
34. Yusupov S. "Avtomobillar konstruksiyasi" 1-qism. O'quv-uslubiy majmua. A.: AndMI. 2019 yil, -b. 54 (493).
35. Двигатель внутреннего сгорания. [Online Image] [Accessed in 2023]. [https://online.mephi.ru/courses/physics/molecular\\_physics/external/images/img\\_47.jpg](https://online.mephi.ru/courses/physics/molecular_physics/external/images/img_47.jpg)
36. Signs of Bad Piston Rings. By Guest Author. [Online Image] [Accessed on 23 March 2020]. [https://repairpal.com/stored\\_images/65180](https://repairpal.com/stored_images/65180)
37. How to Install Piston Rings. By Matt Griswold. [Online Image] [Accessed on 28 February 2022]. <https://www.onallcylinders.com/wp-content/uploads/2014/01/total-seal-piston-rings.jpg>
38. Повышенный расход масла и утечка моторного масла. [Online Image] [Accessed on May 2021]. <https://extxe.com/wp-content/uploads/2021/05/slishkom-vysokij-uroven-masla.jpeg>
39. Piston Ring Function. [Online Image] [Accessed on October 2015]. [https://www.performancemotorsports.eu/wp-content/uploads/2015/10/JE\\_RINGS\\_FIG1.png](https://www.performancemotorsports.eu/wp-content/uploads/2015/10/JE_RINGS_FIG1.png)
40. Piston Ring Function. [Online Image] [Accessed on October 2015]. [https://www.performancemotorsports.eu/wp-content/uploads/2015/10/JE\\_RINGS\\_FIG2.png](https://www.performancemotorsports.eu/wp-content/uploads/2015/10/JE_RINGS_FIG2.png)
41. 3rd Piston ring oil-scraper 4mm. [Online Image] [Accessed on February 2023]. [https://www.cas-shop.com/wp-content/uploads/2023/02/tmp\\_xcore\\_D\\_111\\_11.jpg](https://www.cas-shop.com/wp-content/uploads/2023/02/tmp_xcore_D_111_11.jpg)
42. Howards Cams True Seal Piston Oil Ring. [Online Image] [Accessed in 2023]. [https://www.vividracing.com/wm.php/images\\_2023/HRC4860-4600-5-O-HWC.jpg](https://www.vividracing.com/wm.php/images_2023/HRC4860-4600-5-O-HWC.jpg)
43. Inspecting Burrs on Pistons Using a Digital Microscope. [Online Image] [Accessed in 2023]. [https://static2.olympus-ims.com/data/Image/appnotes/MicroscopeSolutions/inspecting\\_burrs\\_pistons/appnote\\_burrs\\_pistons\\_02.jpg?rev=A3F7](https://static2.olympus-ims.com/data/Image/appnotes/MicroscopeSolutions/inspecting_burrs_pistons/appnote_burrs_pistons_02.jpg?rev=A3F7)
44. A bit on piston rings. [Online Image] [Accessed on 6 April 2015]. [https://contentinfo.autozone.com/znetcs/content/how-to/en\\_US/0996b43f/80/a0/14/84/f15-27.gif](https://contentinfo.autozone.com/znetcs/content/how-to/en_US/0996b43f/80/a0/14/84/f15-27.gif)
45. Piston Ring Gap. [Online Image] [Accessed on 13 November 2020]. [https://scontent.ftas2-1.fna.fbcdn.net/v/t1.6435-9/125325402\\_2942998332599958\\_7392279254357330436\\_n.jpg?nc\\_cat=111&ccb=1-7&nc\\_sid=8bfeb9&nc\\_ohc=RP1-CPHX74IAX9quPnS&nc\\_ht=scontent.ftas2-1.fna&oh=00\\_AfB80jjhDrzhkucly3j5zdboh6UG\\_5yxFPatCk\\_lov\\_Rg&oe=653C6BB3](https://scontent.ftas2-1.fna.fbcdn.net/v/t1.6435-9/125325402_2942998332599958_7392279254357330436_n.jpg?nc_cat=111&ccb=1-7&nc_sid=8bfeb9&nc_ohc=RP1-CPHX74IAX9quPnS&nc_ht=scontent.ftas2-1.fna&oh=00_AfB80jjhDrzhkucly3j5zdboh6UG_5yxFPatCk_lov_Rg&oe=653C6BB3)
46. How to separate a piston from a connecting rod – Quora. [Online Image] [Accessed in 2017]. <https://qph.cf2.quoracdn.net/main-qimg-1ce8476a8cd4f0236226c57bbee50b8-lq>
47. Kiefer Sitten und Bräuche Anwalt floating piston pin einzig und allein Potenzial Hut. [Online Image] [Accessed in 2012]. [https://contentinfo.autozone.com/znetcs/content/how-to/en\\_US/0996b43f/80/a0/12/9e/f19\\_32.gif](https://contentinfo.autozone.com/znetcs/content/how-to/en_US/0996b43f/80/a0/12/9e/f19_32.gif)
48. Yusupov S. "Avtomobillar konstruksiyasi" 1-qism. O'quv-uslubiy majmua. A.: AndMI. 2019 yil, -b. 55 (493).
49. Кривошипно - шатунный механизм двигателя. [Online Image] [Accessed in 2023]. [https://uralmob.com/files/ustroystvo/5.1\\_0.jpg](https://uralmob.com/files/ustroystvo/5.1_0.jpg)
50. How to Tell if Your Crankshaft Is Failing. By Stephen Fogel. [Online Image] [Accessed on 3 November 2019]. [https://repairpal.com/stored\\_images/64940](https://repairpal.com/stored_images/64940)
51. Crankshaft Inspection. [Online Image] [Accessed in 2018]. <https://www.freeasestudyguides.com/graphics/crankshaft-1.jpg?ezimgfmt=ng%3Awebp%2Fngcb32%2Frs%3Adevice%2Frs32-1>
52. Photos taken by Yusupov S. "Tirsakli valni tayyorlash texnologiyasi." In Japan, Nagoya. 10.10. 2016
53. Signs of a Bad Flywheel. By Stephen Fogel. [Online Image] [Accessed on 29 March 2020]. [https://repairpal.com/stored\\_images/64949](https://repairpal.com/stored_images/64949)
54. Flywheel: definition, functions, working principle, problems – studentlesson. [Online Image] [Accessed on June 2020]. <https://i0.wp.com/studentlesson.com/wp-content/uploads/2020/07/flywheel-components.jpg?fit=545%2C379&ssl=1>
55. What is a flywheel and what does it do?. By Jason Unrau. [Online Image] [Accessed on 11 October 2019]. [https://images.autoguru.com.au/next/image?url=https%3A%2F%2Fcdn.autoguru.com.au%2Fmedia%2F1943%2Fin-article-image\\_what-is-a-flywheel.jpg&w=1920&q=60](https://images.autoguru.com.au/next/image?url=https%3A%2F%2Fcdn.autoguru.com.au%2Fmedia%2F1943%2Fin-article-image_what-is-a-flywheel.jpg&w=1920&q=60)



*E'TIBORINGIZ  
UCHUN  
RAHMAT!!!*