

VEHICLES CONSTRUCTION

AVTOMOBILLAR KONSTRUKSIYASI

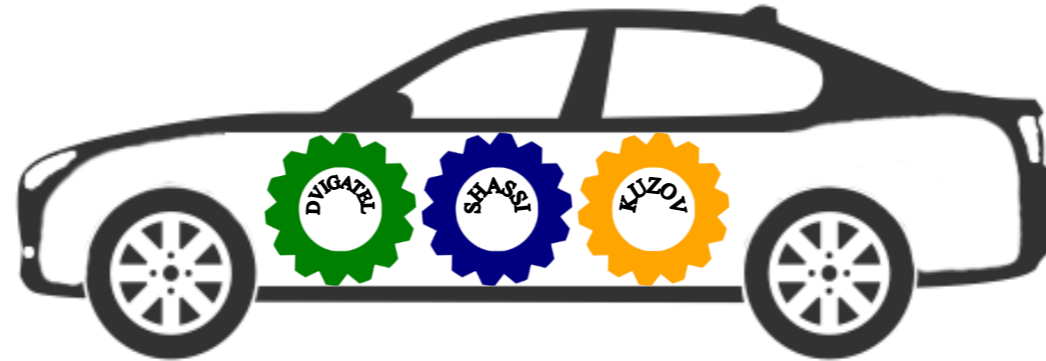

6th Topic: Lubrication System.

(6-Mavzu: Moylash tizimi)

Part 2

Associate Professor: Yusupov Sarvarbek

6-Mavzu: Moylash tizimi

(6th Topic: Lubrication System.)

O'quv rejasini:

- 6.1. Moylash tizimining vazifasi va ishlash prinsipi.
- 6.2. Moylash tizimining usullari.
- 6.3. Moylash tizimida ishlatiladigan moylar.
- 6.4. Moylash tizimi qismlarining konstruksiyasi.**
- 6.5. Dvigatel karterini shamollatish.**

6.4. Moylash tizimi qismlarining konstruksiyasi.

1-mayin filtr; 2-termometr;

3-moy radiatori; 4-saqлагich klapani;

5-jo'mrak; 6-moy qabul qilgich;

7-moy nasosi; 8-reduksion klapan;

9-o'tkazish klapani; 10-dag'al filtr;

11-manometr; 12-asosiy moy kanali;

13-tirsakli valning o'zak bo'yinlari;

14-taqsimlash valining bo'yinlari;

15-koromislo o'qi; 16-moy sathini

o'lchagich; 17-moy quyish bo'g'zi patrubogi.

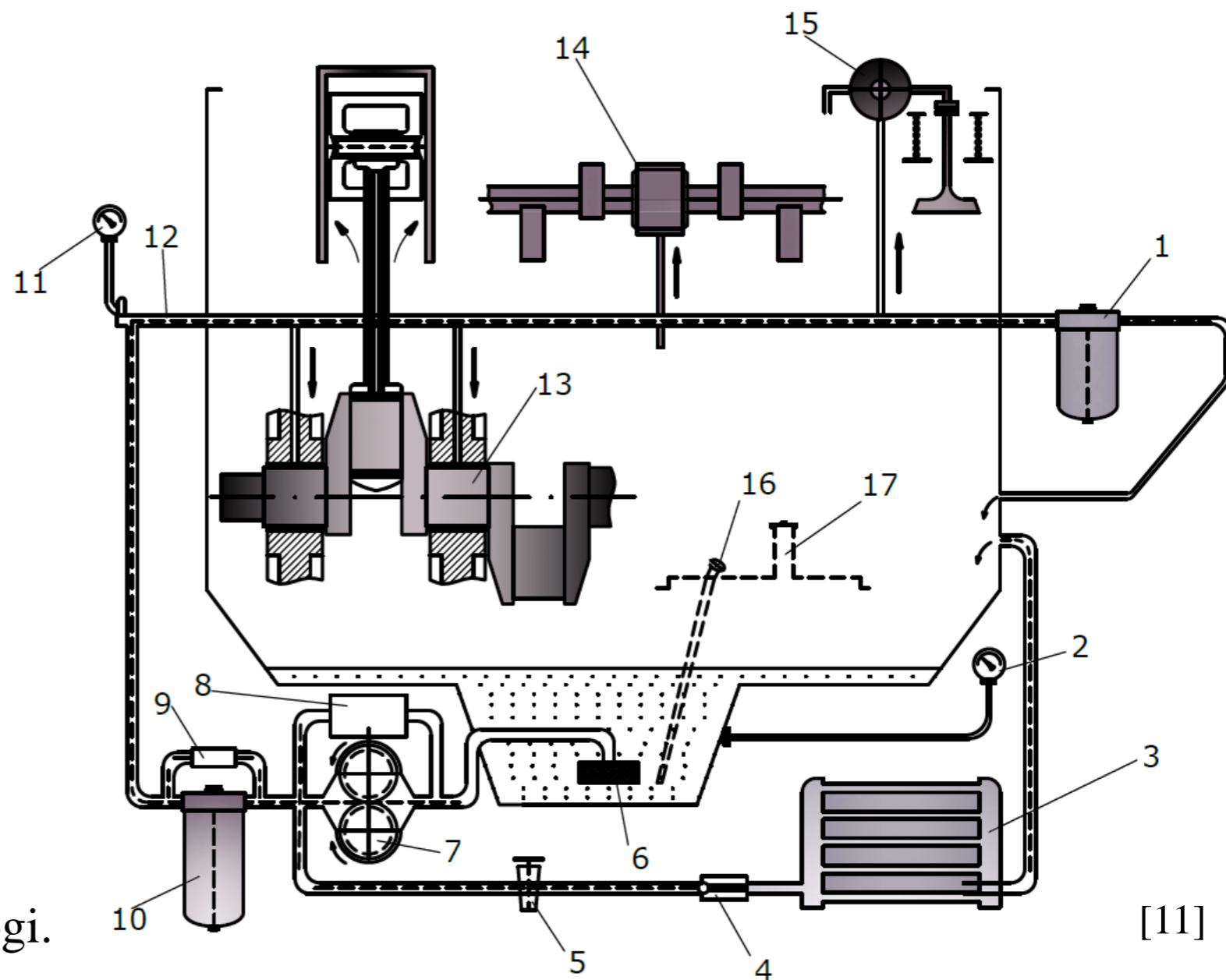

[11]



Moy nasosi

Moy nasosi, moyni bosim ostida dvigatel mexanizmlarining ishqalanuvchi yuzalariga va **moyni tozalash** va **sovutish** tuzilmalariga yuborish uchun **xizmat qiladi.**

Avtomobil dvigatellarida asosan,

shesternali nasoslar ishlatiladi.

Ularning konstruksiyasi oddiy va ishonchli ishlaydi.

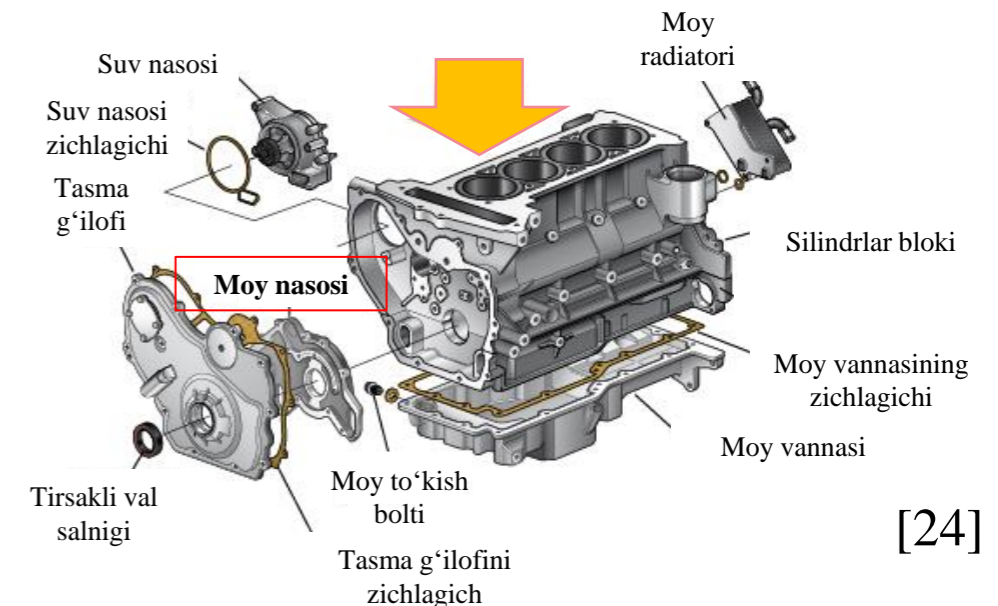
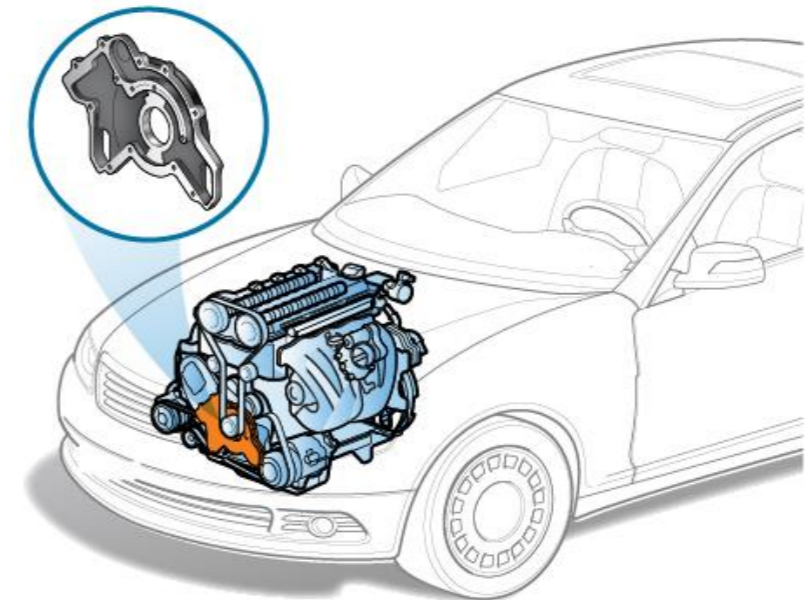

[24]

Nasoslar shesternalarining ilashishi bo'yicha,

➤ **tashqi ilashgan**

➤ **ichki ilashgan**

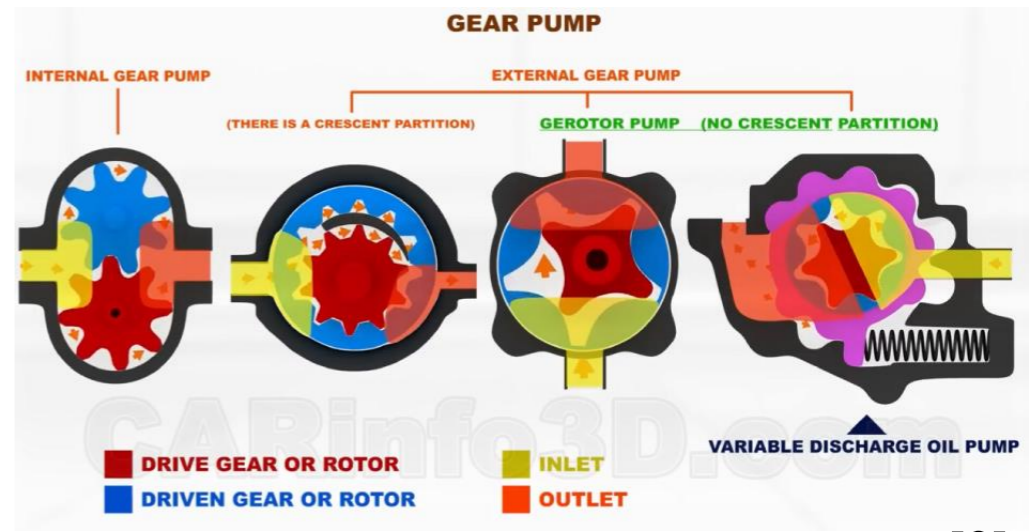
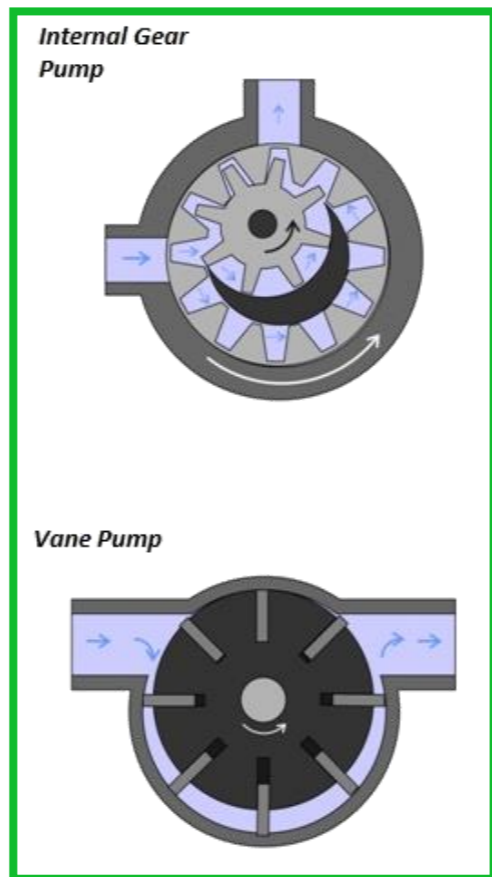
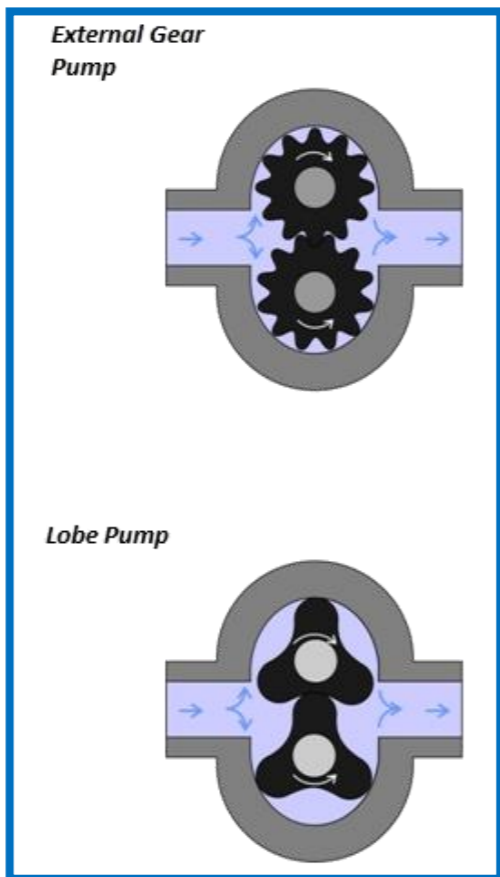

[25]

[8]

Kulachokli
Quyuq
moylar uchun

Tashqi ilashgan shesternali nasoslar o‘z navbatida bir yoki ikki seksiyali, ya’ni bir juft yoki ikki juft shesternali bo‘lishi mumkin.

Zamonaviy yengil avtomobillarda ko‘pincha **ichki ilashishda bo‘lgan**, aylanma harakatni tirsakli valdan oladigan nasoslar ishlatiladi.

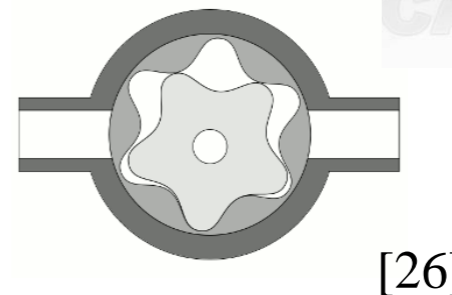
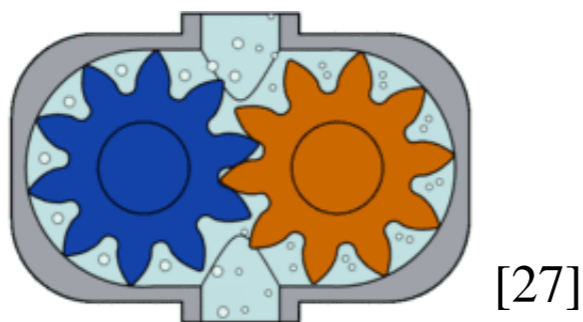

[8]

Katta yuk avtomobillarda esa ikki seksiyali **tashqi ilashishda bo‘lgan** nasoslar ishlatiladi.

Nasos bilan hosil qilinadigan bosim asosiy moy kanalidan moyning **qay darajada sarflanishi**, **tishli g'ildiraklarning aylanishlar chastotasi** va **moyning qovushoqligiga** bog'liq bo'ladi.

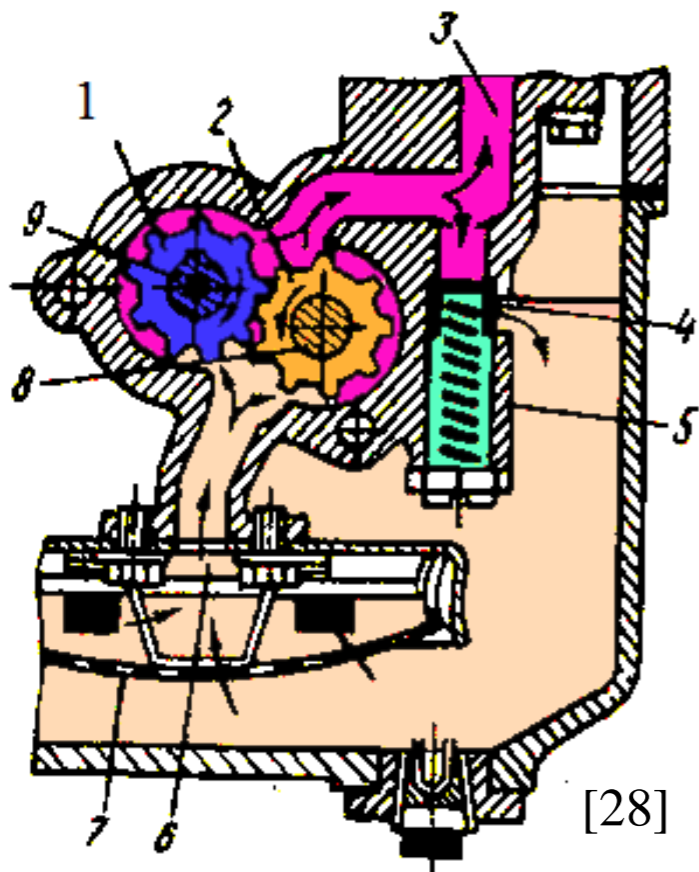

Shesternyali moy nasosining tasviriy chizmasi.

1-yetakchi tishli g'ildirak, 2-yetaklanuvchi tishli g'ildirak,
 3-chiqish kanali, 4-qaytarish kanali,
 5-prujina, 6-nasosning kiritish kanali,
 7-moy qabul qilgich, 8-yetaklanuvchi tishli g'ildirak o'qi,
 9-yetakchi tishli g'ildirak o'qi.

Tizimdagi moy bosimini belgilangan me'yoridan ortib ketmasligini reduksion klapan ta'minlaydi.

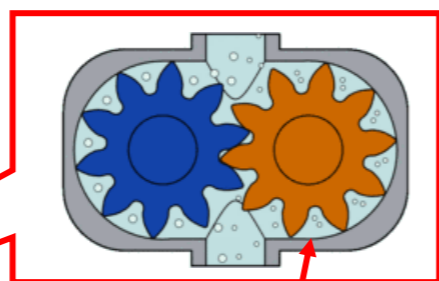
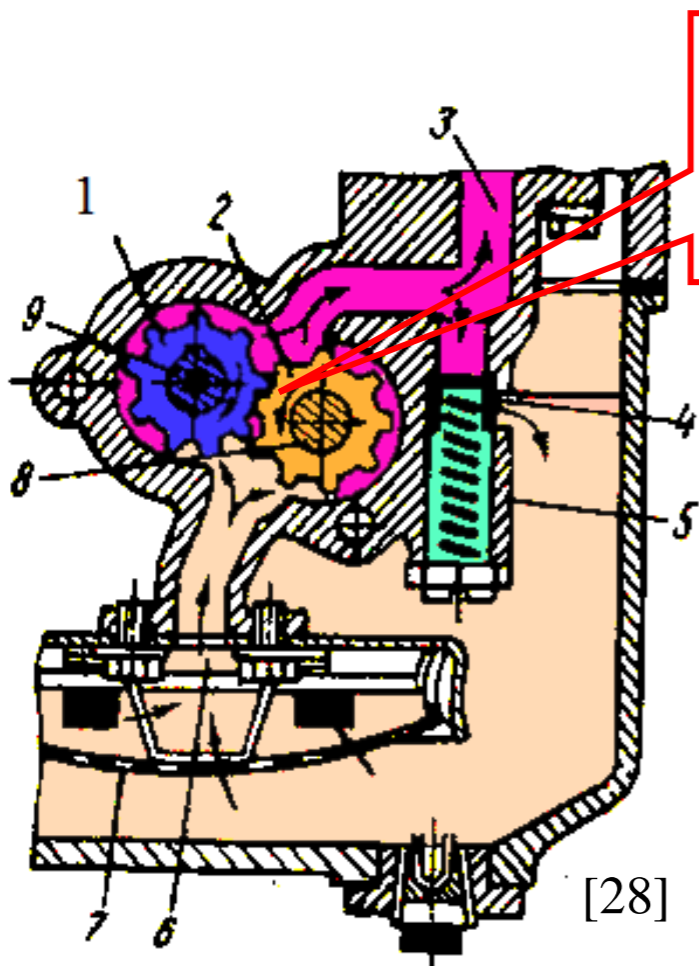

[27]

**Radial
tirqish –
0,06-0,1 mm**

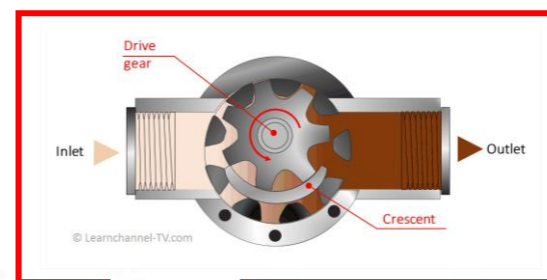

[29]

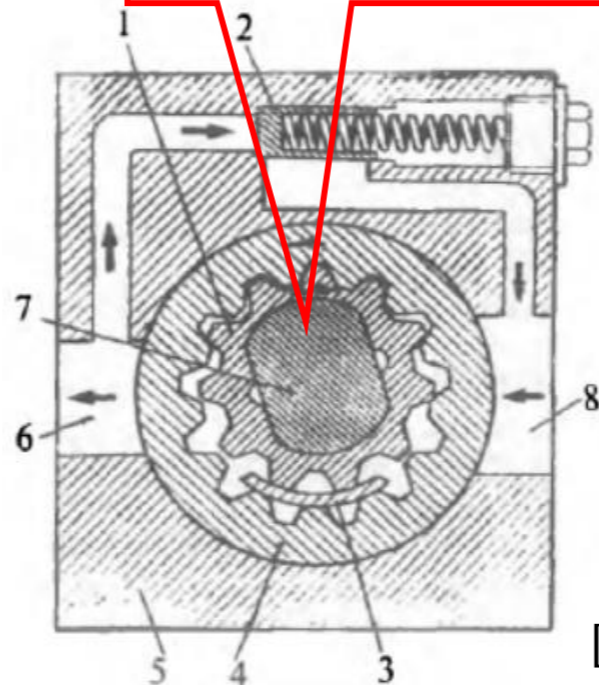

[28]

$$P_{Ben.dv} = 0,3 \dots 0,5 \text{ MPa}$$

$$P_{Diz.dv} = 0,5 \dots 0,7 \text{ MPa}$$

1 va 4-tishli g'ildiraklar;
2-reduksion klapan;
3-to'siq; 5-korpus;
6 va 8-haydash va so'rish
kanallari; 7-tirsakli val.

Shesternalari ichki ilashgan moy nasosining sxemasi:

Moy qabul qilgich -

- moy tarkibidagi yirik ifloslangan zarrachalarni ushlab qoluvchi birlamchi filtr vazifasini o‘taydi va qo‘zg‘almas holda karter tubining eng pastki qismida joylashadi.

Avtomobil qiya turganda ham **moy qabul qilgich**, karter tubidagi moyga tegib turadi va tarmoqqa **havo so‘rilishiga yo‘l qo‘ymaydi**.

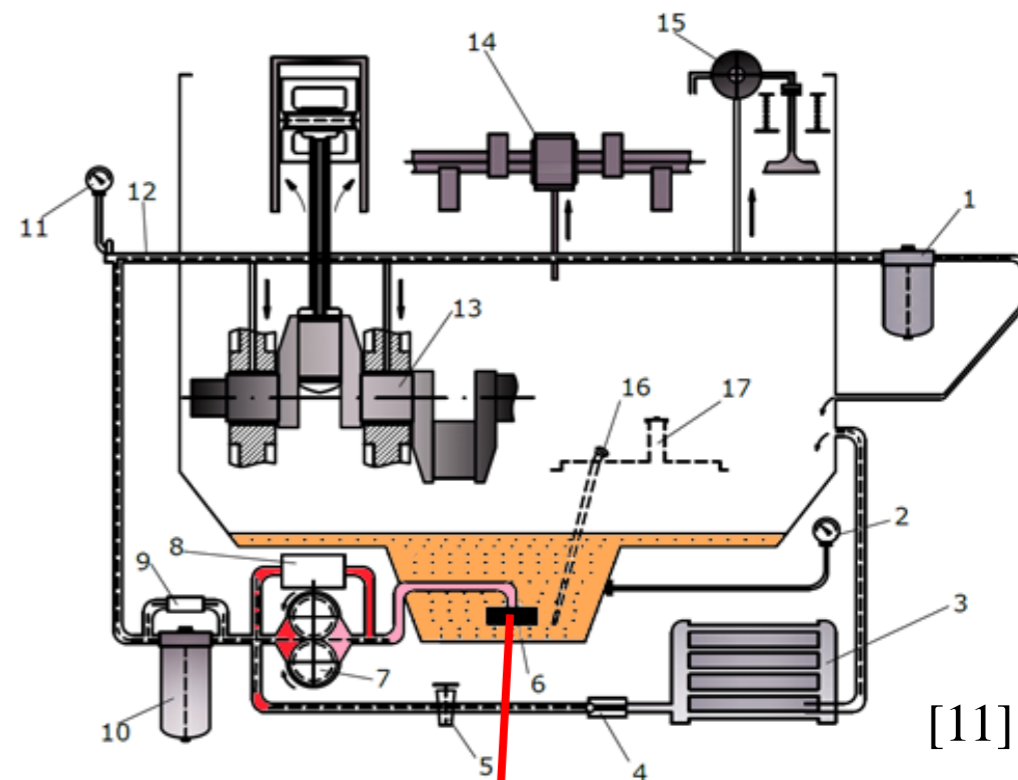

[11]



[30]

Moy filtrlari -

- moyni dvigatel detallarining yeyilishi natijasida hosil bo'lgan metall zarrachalaridan va boshqa ifloslantiruvchi narsalardan tozalaydi.

➤ **To'la oqimi** (*tarmoqda harakatlanayotgan moyning ko'p qismi filtrlardan o'tkaziladi*);

➤ **To'la bo'lmagan oqimli** (*10...15% moy filtrdan o'tkaziladi*) bo'ladi.

Ishlatilishi bo'yicha:

Dizel dvigatel uchun

➤ *Dag'al tozalash filtrlari;*

➤ *Mayin tozalash filtrlari.*

Benzinli dvigatel uchun

➤ *Mayin tozalash filtrlari.*

Dag'al tozalash filtrlari.

Moyni yirik mexanik zarrachalardan va smola quyqalardan tozalash uchun dag'al filtrlardan foydalaniladi.

Ular plastinka-tirqishli yoki **simto'qli** bo'lishi mumkin.

Bu filtrlar yirik ifloslantiruvchi zarrachalarni ushlab qoluvchi birlamchi filtr hisoblanadi.

< 0,08 zarrachalar tutib qoladi.

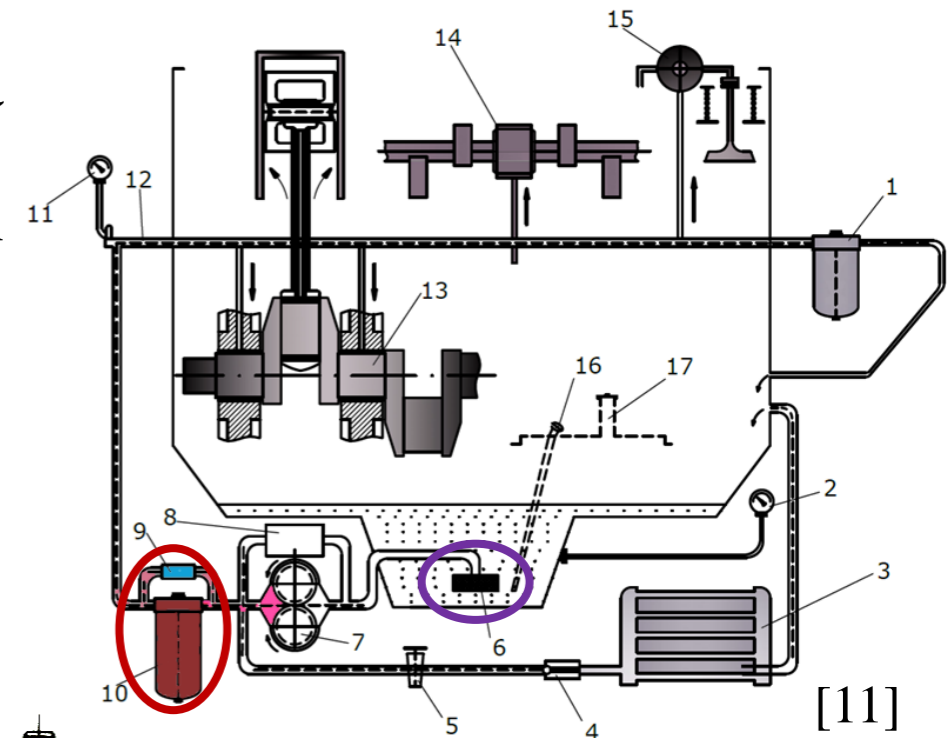

[11]

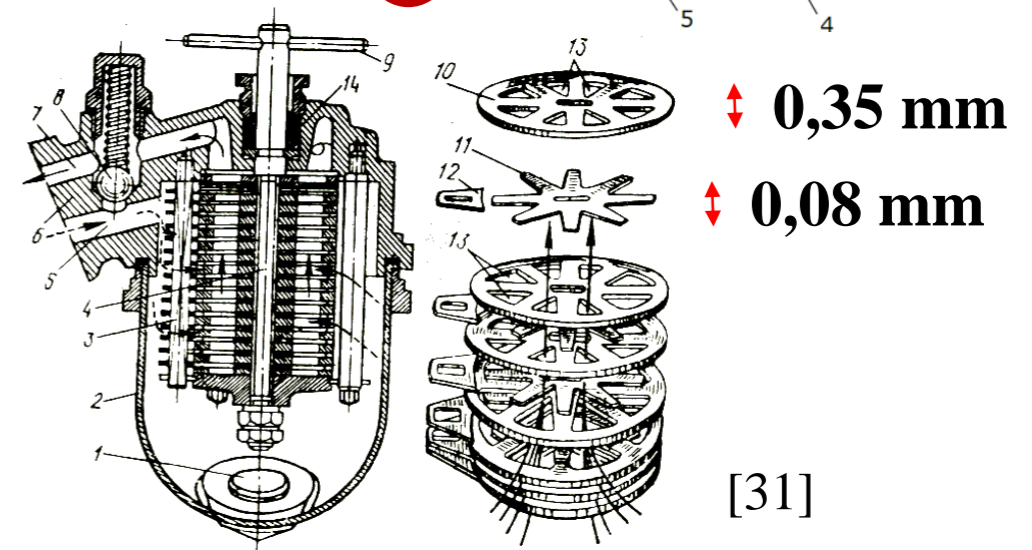

[31]



Mayin tozalash filtrlari -

- zamonaviy avtomobil dvigatellarida **tirqishli** yoki **markazdan qochma** mayin tozalash filtrlari ishlatiladi.

Mayin tozalash filtrlari moyni (**dag'al tozalash filtridan o'tgandan so'ng**) 1-2 mkm gacha bo'lgan mexanik zarrachalardan to'la tozalaydi, shuningdek yelimlashgan moy (**smola**) va **moy kuyindilarini tutib qoladi.**

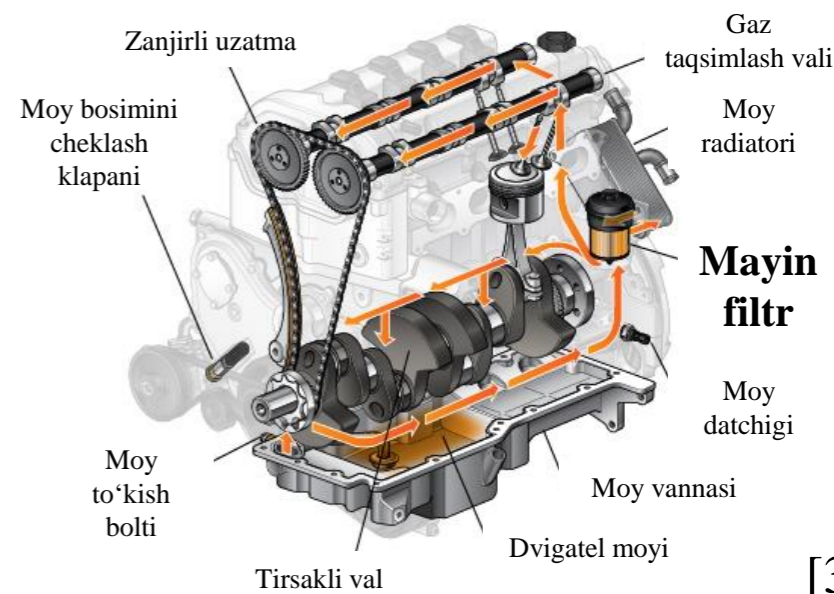
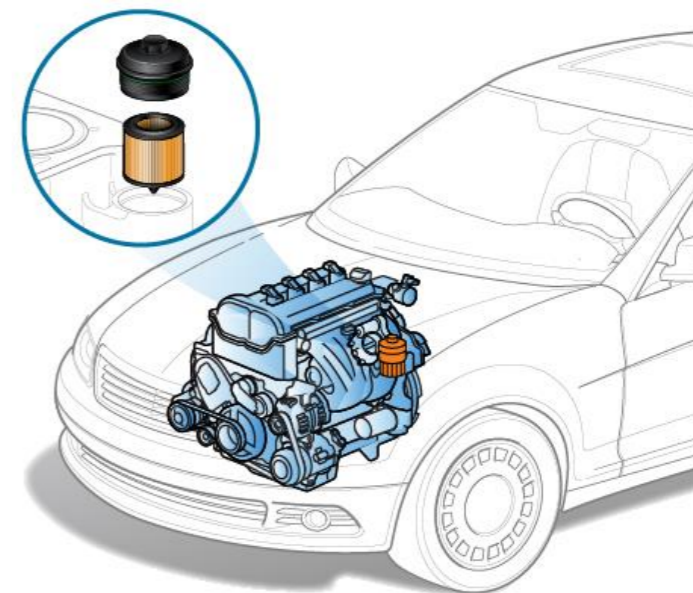

Markazdan qochma mayin filtrlar **sentrifuga** deb ataladi.

Bu turdagi sentrifugalar reaktiv yuritmaga ega bo‘lib, qarama - qarshi yo‘nalishda bosim ostida otilib chiqayotgan moy oqimi ta’sirida rotorni aylantiradi.

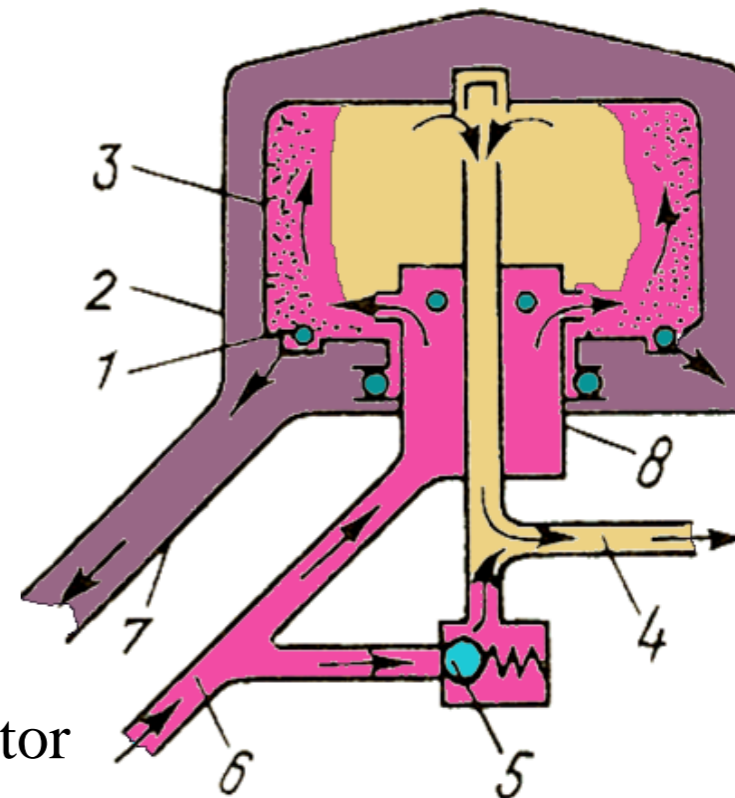

1-jiklyor, 2-korpus, 3-rotor, 4-rotor
vali tuynugi, 5-klapan, 6-kiritish
tuynugi, 7-chiqarish tuynugi.

[33]

Moy radiator -

- dvigatelning ishlashi natijasida qizigan moy haroratini me'yorida saqlash vazifasini bajaradi.

Moy radiatorlari asosan yuk avtomobillarida qo'llaniladi, chunki ular ko'pincha og'ir yo'l sharoitlarida ishlaydi.

Shuningdek radiatorlar o'tuvchanligi yuqori va dvigateli nisbatan katta quvvatga ega bo'lgan ayrim yengil avtomobillarda ham qo'llaniladi.

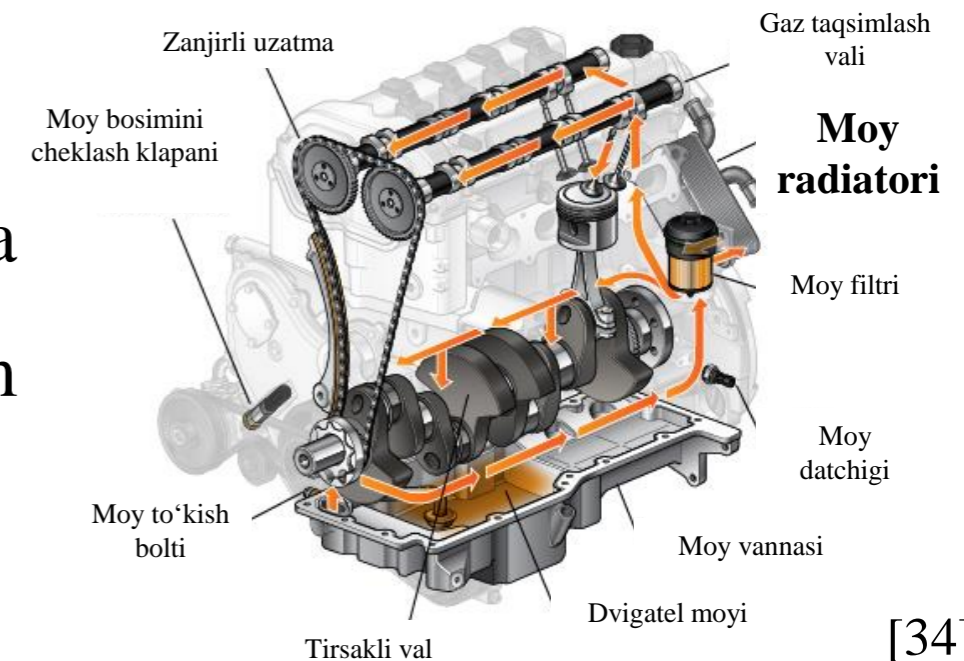
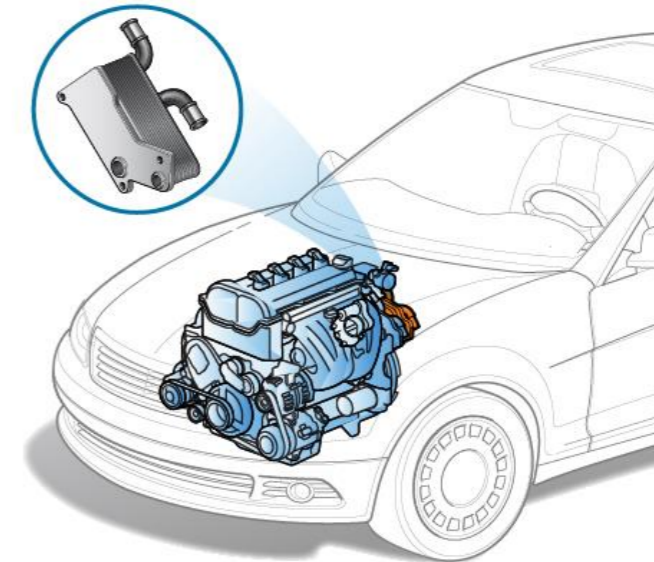

[34]

Moy radiatori tarmoqqa ketma-ket ulansa, u o'tkazish klapani bilan ta'minlanadi.

Radiator moy tarmog'iga muvoziy ulansa, saqlagich klapani o'rnatiladi.

U tarmoqdagi moyning bosimi **0,10 MPa** dan oshganda ochiladi.

Natijada moy radiatorga o'tib sovutiladi.

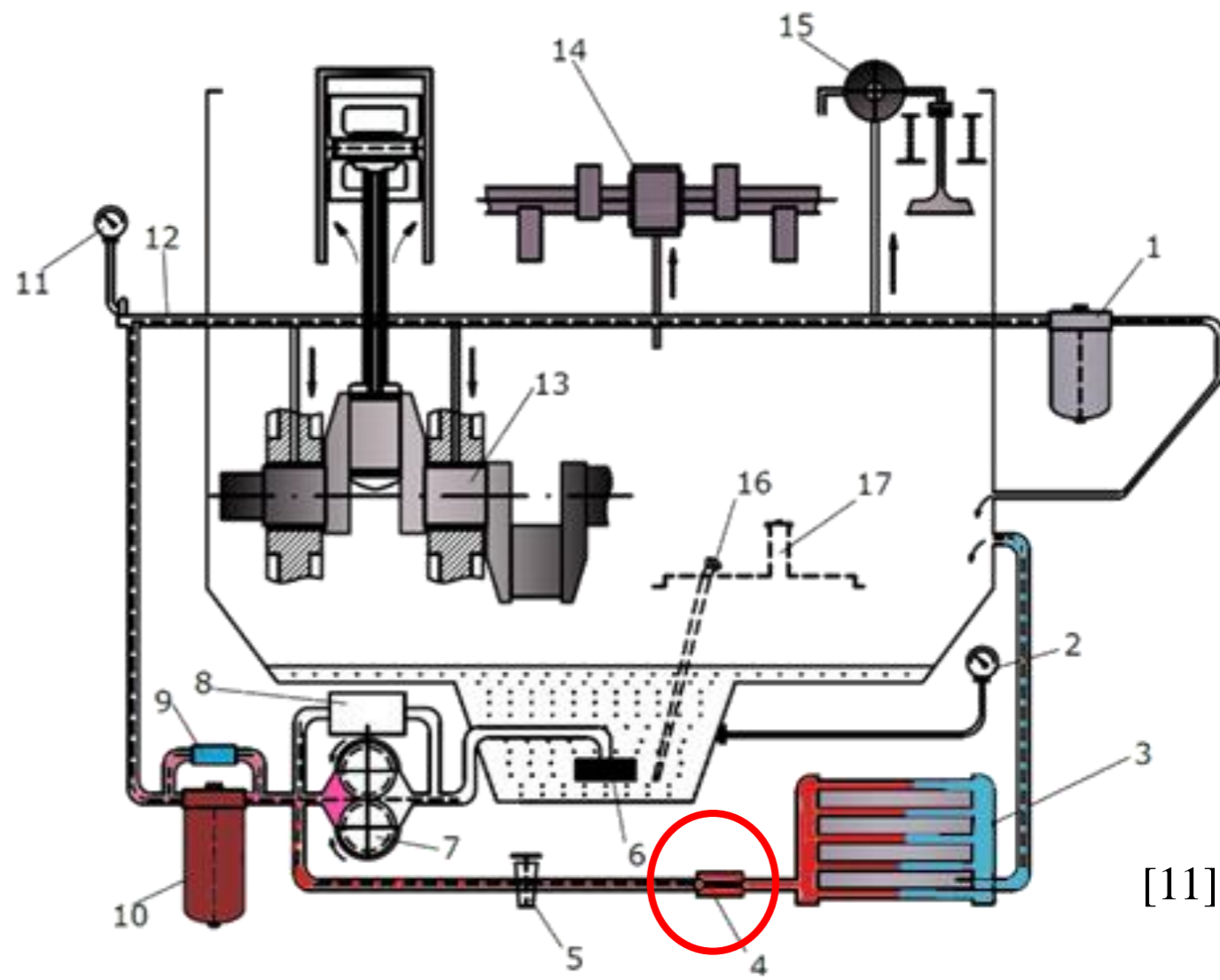

[11]

Konstruksiyasi bo'yicha moy radiatorlar:

Bunday radiatorlar puxta va aniq ishlayd.

U karter tubidagi moyni
75...95° C da ushlab turadi.

- **Naychali;**
- **Naycha plastinkali.**

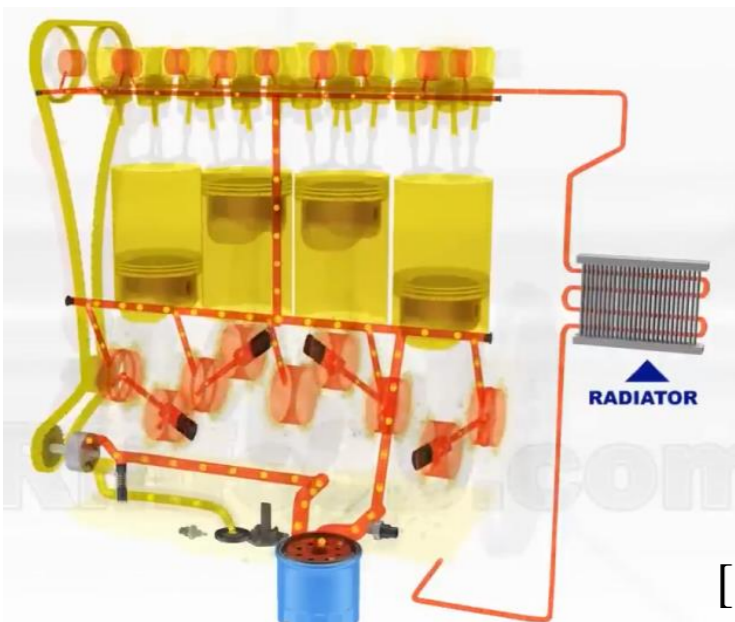

[8]

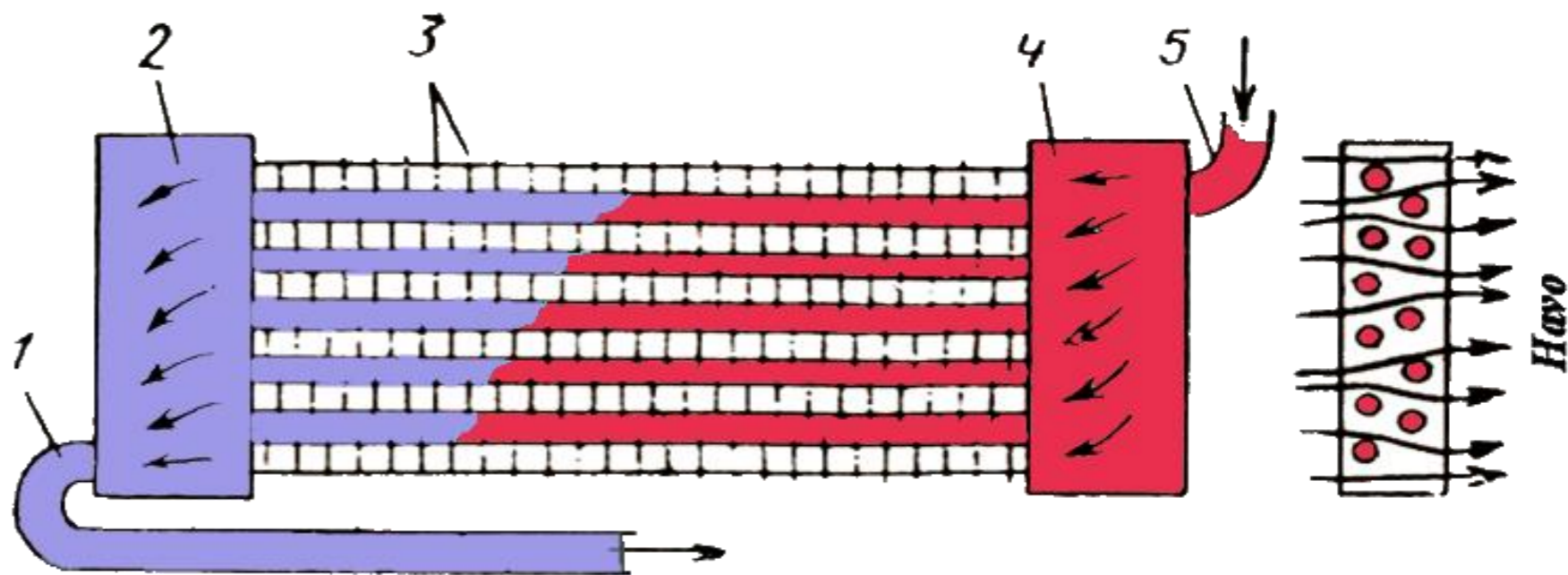

1 va 5 – kiritish va chiqarish naychalari, 2 va 4 – moy yig'uvchi bakchalar, 3 – qovurg'ali moy sovituvchi naychalar.

[35]

Moy bosimini ko'rsatuvchi datchik

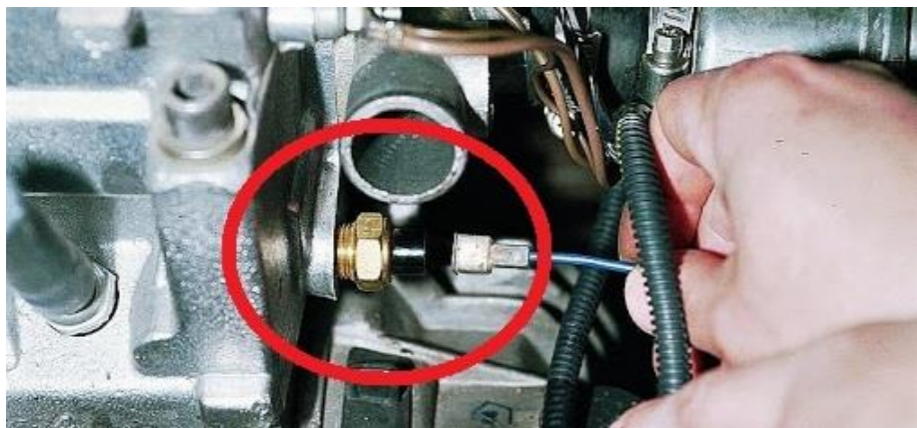

[37]



[39]

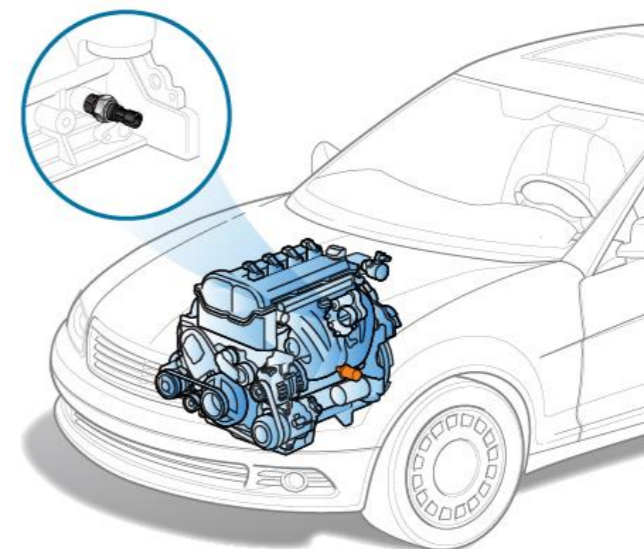

Moy bosimi >0,3 MPa

Moy bosimi <0,3 MPa

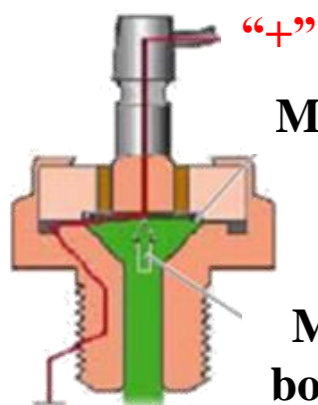

Membrana

Moy bosimi

Massa



[8]

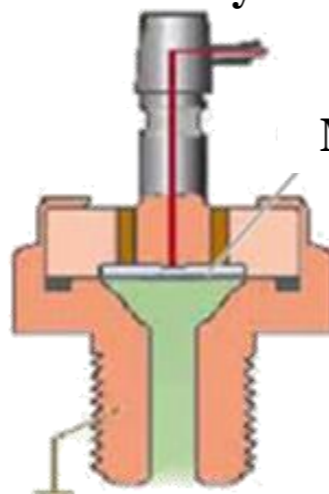

Membrana

[38]

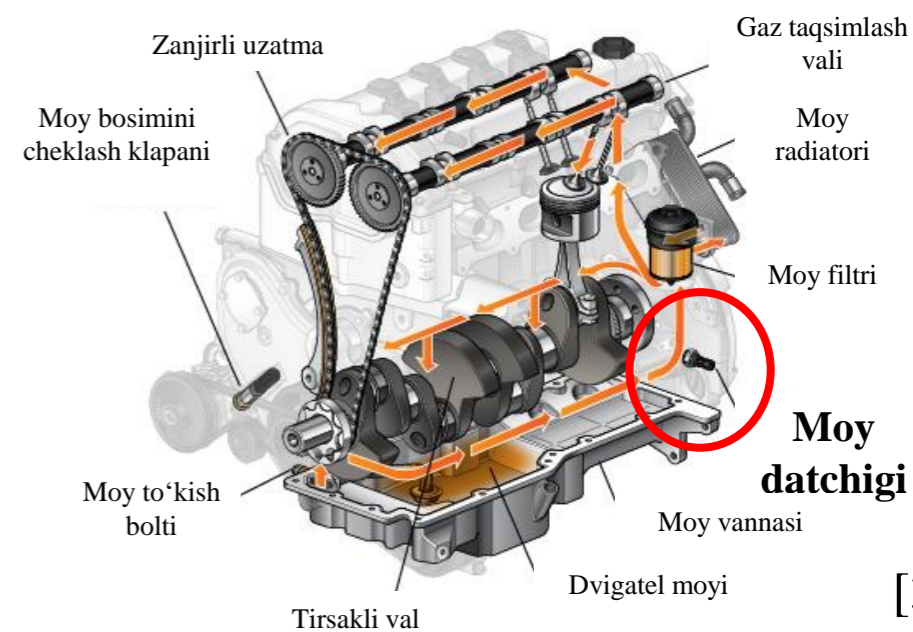

Moy datchigi

[36]

Karter va inteligent moy datchikning nazorat sxemasi

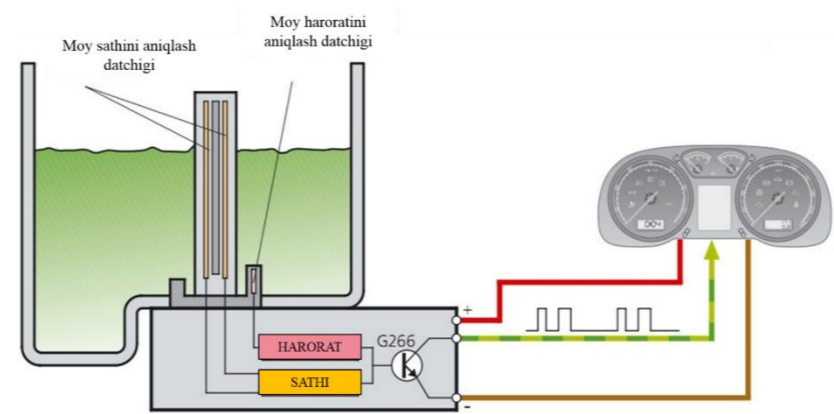
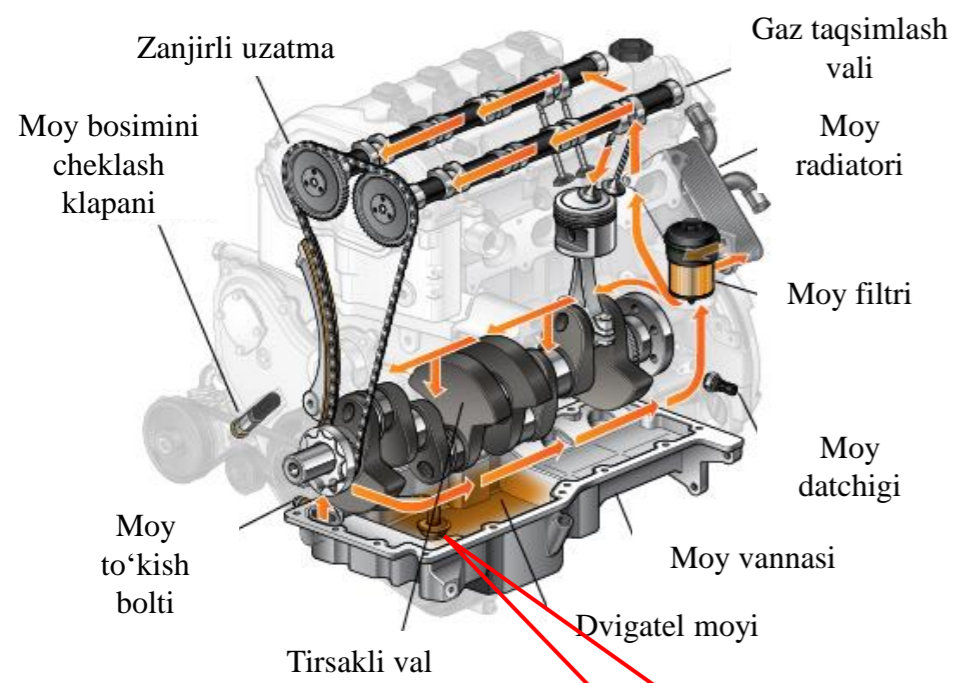

[41]

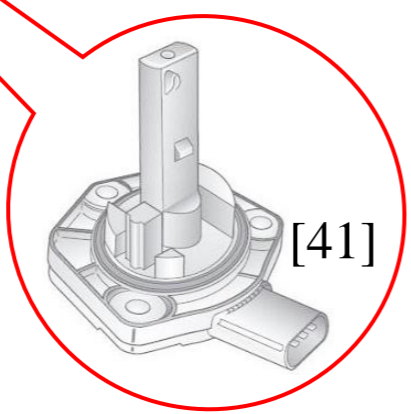
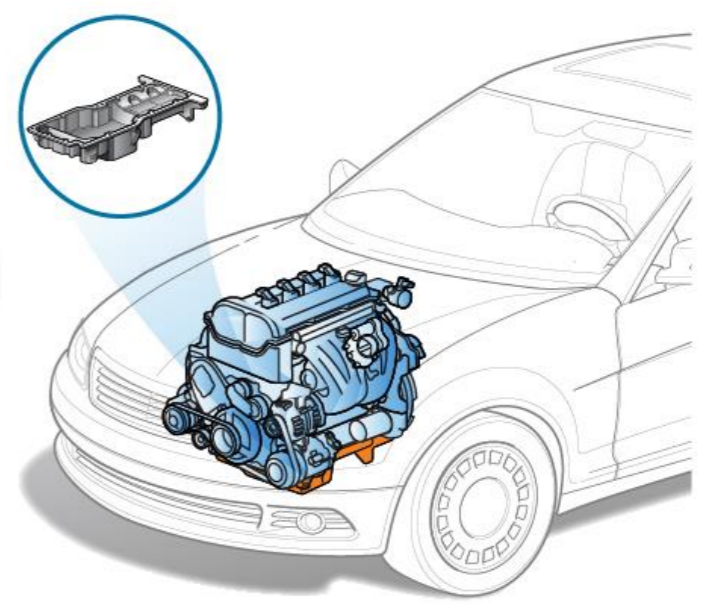

[41]



[8]

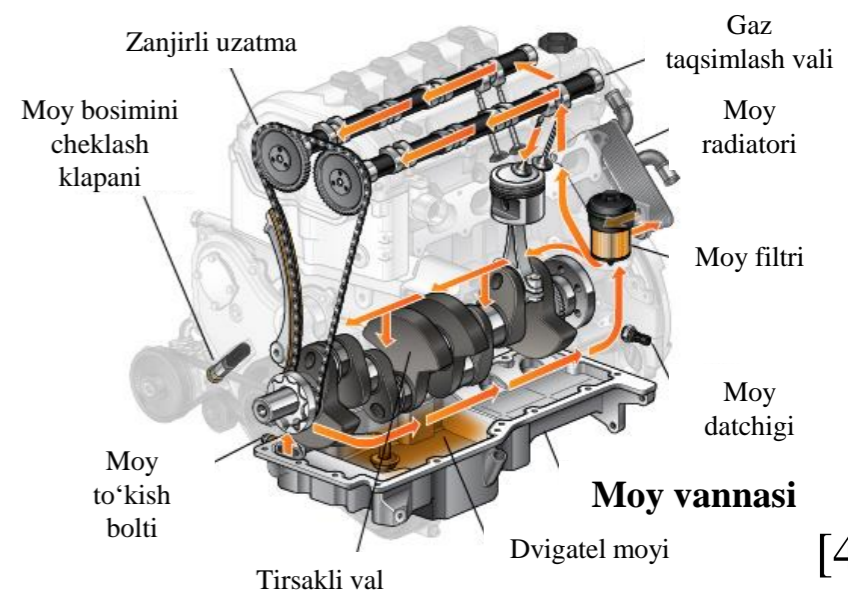

[40]



[42]

6.5. Dvigatel karterini shamollatish.

Silindrlarda hosil boʻlgan gazlar porshen halqalarining tirqishlari boʻylab karterga oʻtadi.

Bu gaz **yonuvchi aralashma**, **toʻla va qisman yongan mahsulotlardan iborat boʻlib**, karter gazlari deb ataladi.

Bu gazlarning tarkibida **yonilgʻi** va **suv bugʻi**, **karbonat angidrit**, **oltingugurt**, **azot** va qisman **karbon vodorod** birikmalari boʻladi.

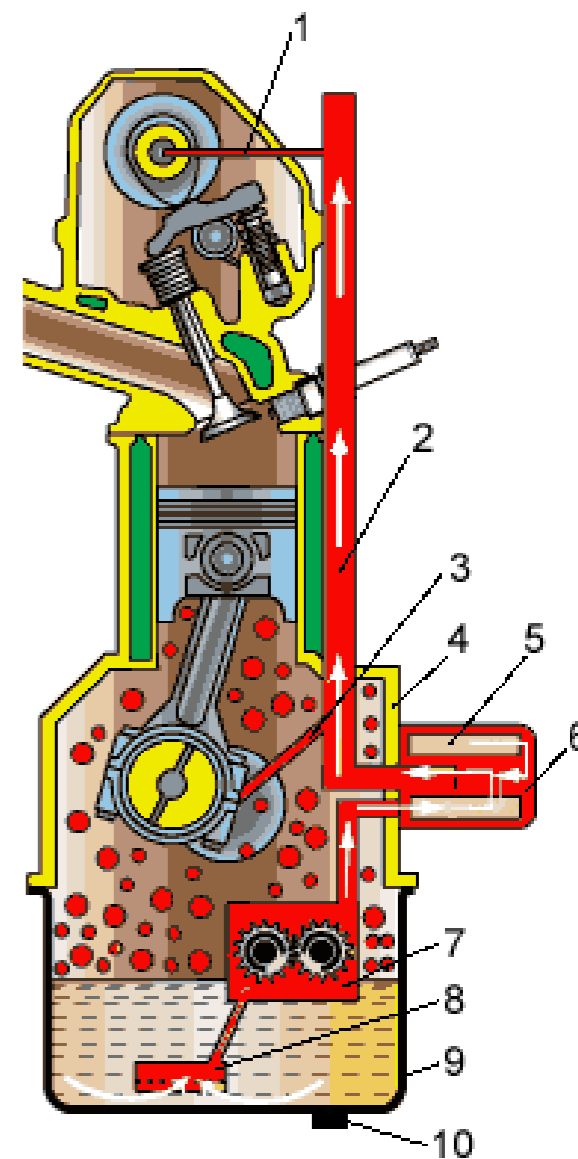

[43]

Yonilg‘i bug‘i tomchiga aylanib moyni suyultiradi,
suv bug‘i va boshqa birikmalar moyni oksidlaydi,
natijada **moyning sifati yomonlashadi.**

**Karter gazlarining moyga yomon ta’sirini
kamaytirish uchun**

**ularni karter bo’shlig‘idan uzluksiz ravishda
chiqarib turish zarur.**

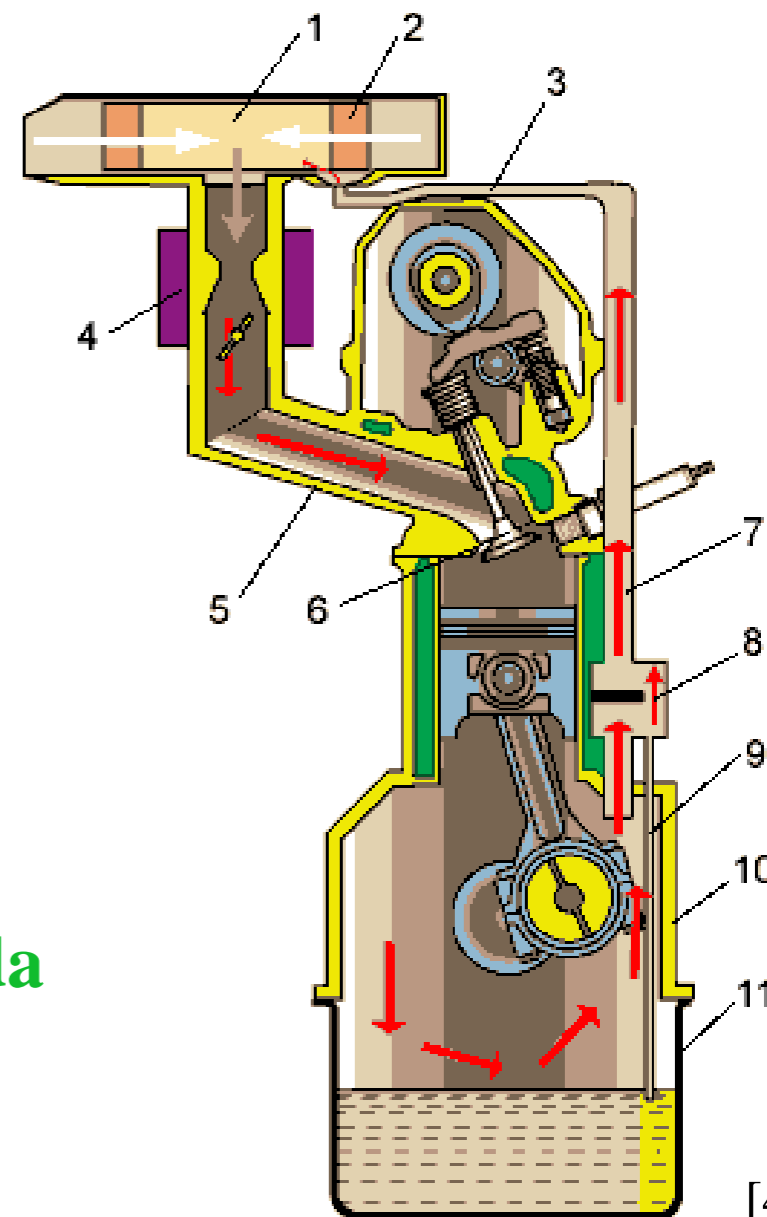

[44]

Dvigatellar karter bo'shlig'ini shamollatish tasviriy chizmalari:

a) ochiq shamollatish:

1-qiya kesikli naycha;

2-bo'linma;

3-to'r filtr.

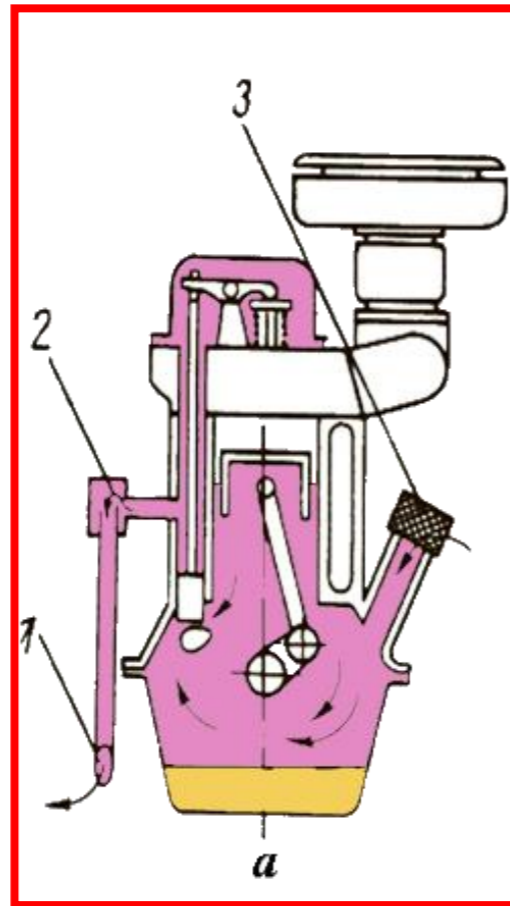

b) yopiq-tortib olish yo'li bilan shamollatish:

4-klapan mexanizm qopqog'i; 5-naycha;

6-filtrlovchi qism.

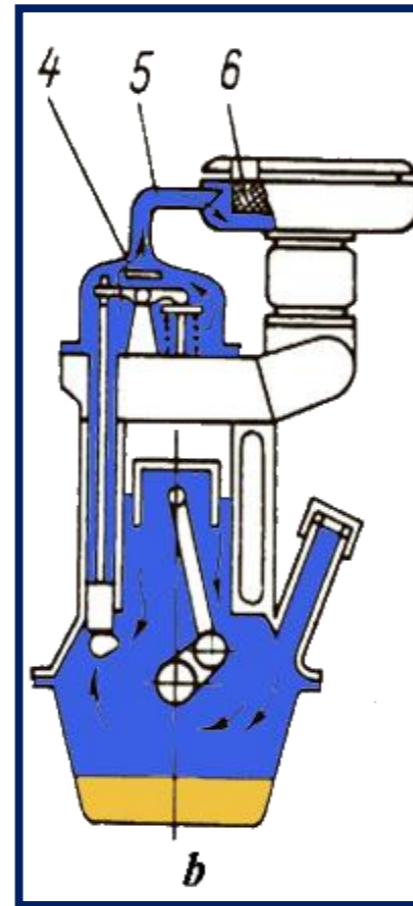

c) yopiq-majburiy shamollatish:

7-moy qaytargich;

8-klapan;

9-naycha;

10-kiritish quvuri;

11-karburator.

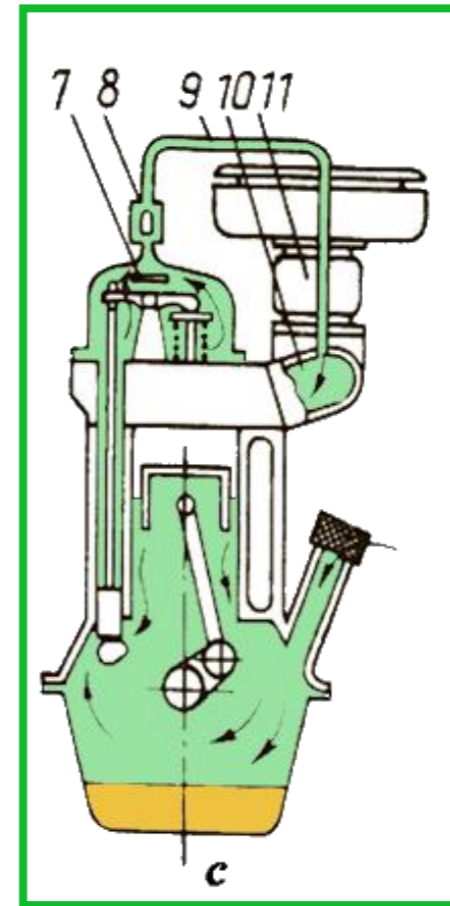

[45]

Dvigatellar karter bo'shlig'ini shamollatilishi

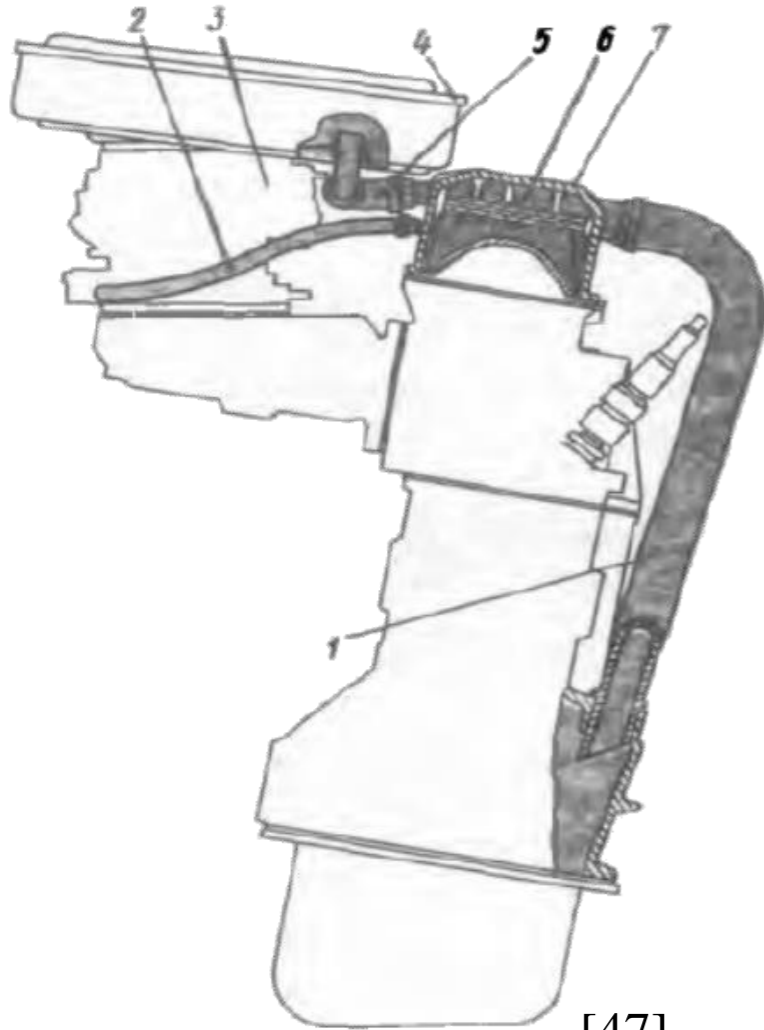

[47]

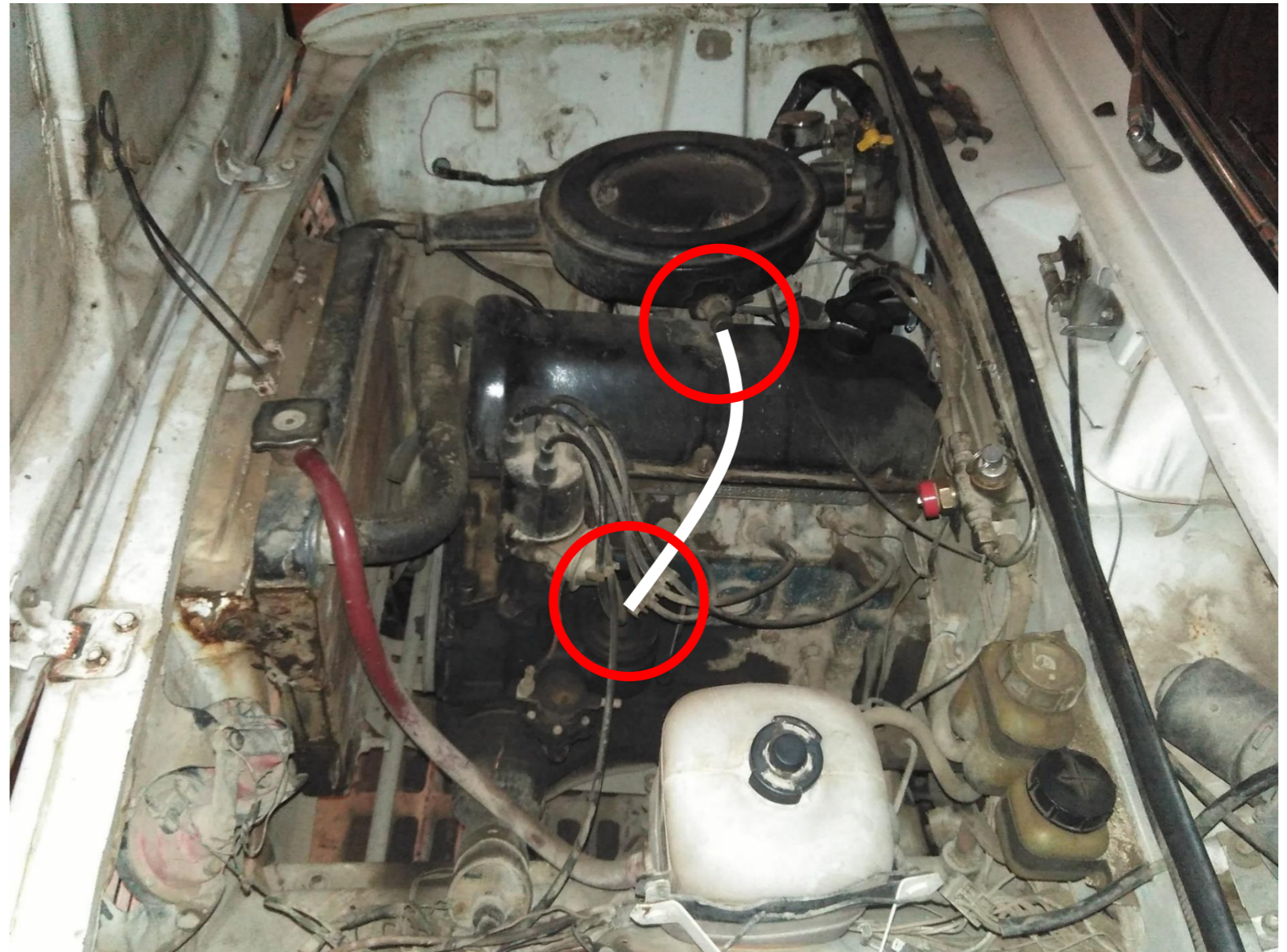

[46]

24. Signs and Symptoms of a Bad or Failing Oil Pump. By Mia Bevacqua. [Online Image] [Accessed on 17 January 2022]. https://repairpal.com/stored_images/64606
25. Useful information on positive displacement pumps. [Online Image] [Accessed in 2022]. <https://www.michael-smith-engineers.co.uk/mse/uploads/UsefulInfo/UsefulInfoPD/ROTARY-POSITIVE-DISPLACEMENT-PUMP-DESIGNS.jpg>
26. Motor Yağlama Sistemi. [Online gif] [Accessed on 21 January 2020]. https://www.motordersi.com/wp-content/uploads/2020/01/rotorlu_tip_yag_pompasi.gif
27. Gear pump – Wikipedia. [Online gif] [Accessed on 27 September 2023]. https://upload.wikimedia.org/wikipedia/commons/thumb/f/f8/Gear_pump_animation.gif/320px-Gear_pump_animation.gif
28. E.Fayzullayev. Transport vositalarining konstruksiyasi. Darslik. I-qism. -T.: “Yangi asr avlodi”, -2006 yil, 91-93 bet.
29. Gear Pump Diagram. [Online gif] [Accessed on April 2020]. <https://learnchannel-tv.com/wp-content/uploads/2020/04/Internal-Gear-Pump-how-it-works.gif>
30. Yusupov S. “Avtomobillar konstruksiyasi” 1-qism. O‘quv-uslubiy majmua. A.: AndMI. 2019 yil, -b. 94 (493).
31. Yusupov S. “Avtomobillar konstruksiyasi” 1-qism. O‘quv-uslubiy majmua. A.: AndMI. 2019 yil, -b. 87 (493).
32. Oil filter. [Online Image] [Accessed in 2019]. https://repairpal.com/stored_images/64579
33. Yusupov S. “Avtomobillar konstruksiyasi” 1-qism. O‘quv-uslubiy majmua. A.: AndMI. 2019 yil, -b. 88 (493).
34. Oil Cooler. [Online Image] [Accessed in 2019]. https://repairpal.com/stored_images/64953
35. Yusupov S. “Avtomobillar konstruksiyasi” 1-qism. O‘quv-uslubiy majmua. A.: AndMI. 2019 yil, -b. 89 (493).
36. Signs You Have a Bad Oil Pressure Sensor. By Mia Bevacqua. [Online image] [Accessed on 14 May 2018]. https://repairpal.com/stored_images/64955
37. Датчик температуры двигателя ваз 2114 показывает 130. [Online image] [Accessed on 12 December 2022]. <https://taxi-arkhangelsk.ru/wp-content/uploads/2022/01/624e165c877c3465c3c731ab526081a2.jpg>
38. Датчики давления масла G193 и G194. [Online image] [Accessed on December 2012]. <https://vwmir.ru/wp-content/uploads/2012/12/d45.jpg>
39. Датчик давления масла. [Online image] [Accessed on 14 June 2022]. <https://a.d-cd.net/NJNDF0I91eNoVLKEtMXECWLQUc-960.jpg>
40. Oil Pan. By Stephen Fogel. [Online image] [Accessed on 10 December 2019]. https://repairpal.com/stored_images/64954
41. Motor Yağ Seviye Göstergesi - Motor Yağı Seviyesi Ne Kadar Olmalı? [Online image] [Accessed in 2018]. <https://1.bp.blogspot.com/-UT-IljqY8-4/XFrMJYIfRzI/AAAAAAAAAKqo/DGjIjLUJrZsaC8ydlQISuxpfAzG3AepJACK4BGAYYCw/s200/yag%2Bseviye%2Bsens%25C3%25B6r%25C3%25BC.JPG>
42. S.Yusupov. Dvigatelning moylash tizimida tirsakli val va shatun bo‘yinlariga moysiz ishlagandagi holati. [Image taken by S.Yusupov]. Andijon. -2015 y.
43. Система смазки. [Online image] [Accessed in 2018]. https://www.prava.uz/img/auto/8_1.gif
44. Система смазки. [Online image] [Accessed in 2018]. https://www.prava.uz/img/auto/8_3.gif
45. Yusupov S. “Avtomobillar konstruksiyasi” 1-qism. O‘quv-uslubiy majmua. A.: AndMI. 2019 yil, -b. 91 (493).
46. S.Yusupov. Dvigatel karterini shamollatish tizimi. [Image taken by S.Yusupov]. Andijon. -2015 y.
47. E.Fayzullayev. Transport vositalarining konstruksiyasi. Darslik. I-qism. -T.: “Yangi asr avlodi”, -2006 yil, 100 bet.

*E'TIBORINGIZ
UCHUN
RAHMAT!!!*