

Broadcasting Towers Operation

WEEK 7 – Generators and UPS

University: Rwanda Polytechnic – Tumba College

Lecturer: NSHIMIYIMANA Arcade

Objectives

At the end of the topic students will be able to:

1. Understand the basics of Generator and UPS.
 2. Explain the working principle of Generator and UPS.
 3. Explain the applications of Generator and UPS.
-

Rationale

- Broadcasting towers require a reliable power system to ensure they continue to operate. Especially, this is very crucial in remote locations.
 - A generator is typically used as the primary power source, providing stable electricity to the tower.
 - In case of a power outage or generator failure, an Uninterrupted Power Supply or UPS steps in to provide immediate backup power, ensuring that there shouldn't be any disruption in broadcasting.
 - The Automatic Transfer Switch (ATS) plays a crucial role which is to automatically switch between the generator and UPS, to ensure maintaining seamless power supply. Additionally, an Automatic Voltage Regulator (AVR) makes that voltage levels remain consistent, protecting sensitive broadcasting equipment from potential damage due to power fluctuations.
-

7.0 General introduction

- A Generator: is an Electrical Generator, which is driven by a prime-mover, converts mechanical energy into electrical energy.
 - At present, most of the generators are of AC generator; rotating magnetic field induces voltage across the stator windings, producing AC output and DC generators, commutator ensures that current flows in a single direction, producing DC output. (Electrical Equipment, B Koti Reddy, Indian Institute of Technology Hyderabad, 2021.)
 - An Uninterruptible Power Supply (UPS) is a device which supplies power to devices for a fixed amount of time without stopping even when there are problems occurring with utility power and other power sources.
-

7.1 Generator

- Generator is a machine that converts mechanical energy into electrical energy. It works based on principle of faraday's law of electromagnetic induction. The faradays law states that whenever a conductor is placed in a varying magnetic field, EMF is induced, and this induced EMF is equal to the rate of change of flux linkages.
 - This EMF can be generated when there is either relative space or relative time variation between the conductor and magnetic field.
 - The important elements of a generator are: Magnetic field and Motion of conductor in magnetic field
-

7.1 Generator cont'd

- A schematic diagram of the construction of a generator is provided here:

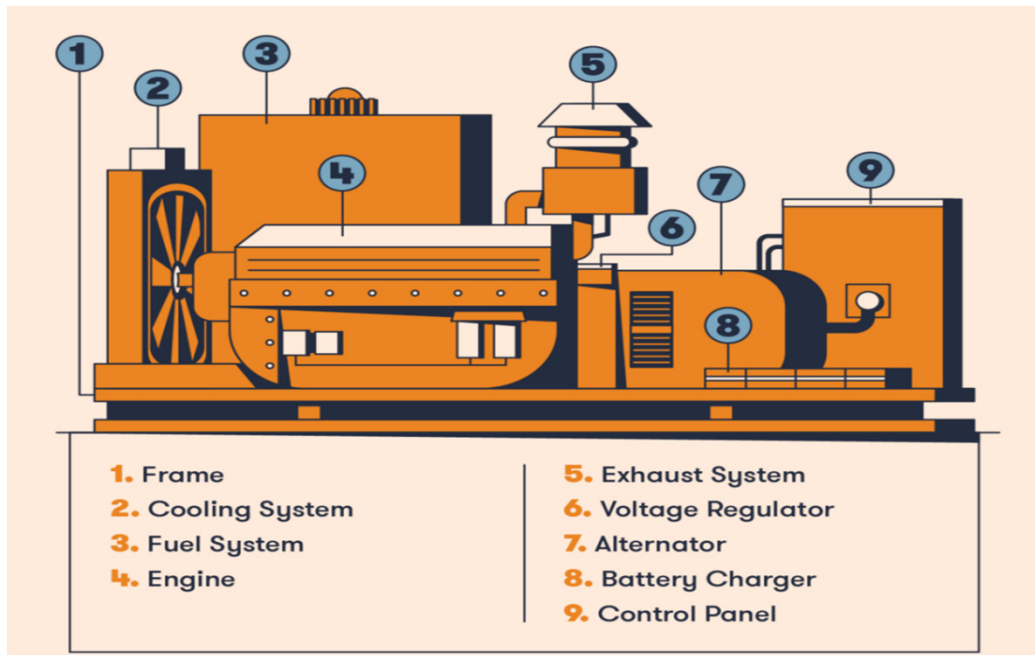

(<https://www.bigrentz.com/blog/how-do-generators-work>)

7.1 Generator cont'd

- Modern electric generators can vary in size and application, but their inner workings are generally the same across the board with basic components:
 - **Frame** that contains and supports the generator's components. It allows humans to safely handle the generator and protects it from damage.
 - **Engine** that supplies the mechanical energy that is converted into electrical output. The engine's size determines the maximum power output, and it can run on a variety of fuel types.
 - **Alternator** contains additional components that work together to produce the electrical output. These include a stator and rotor, which are responsible for creating a rotating magnetic field and producing an alternating current (AC) output.
-

7.1 Generator cont'd

- **Fuel system**, usually generators come with an attached or external fuel tank that supplies the engine with fuel. The fuel tank is connected via supply and return pipes and commonly contains gasoline or diesel fuel.
 - **Exhaust system**, diesel and gasoline engines emit exhaust containing toxic chemicals. The exhaust system safely manages and disposes off these gases through a pipe made of iron or steel.
 - **Voltage regulator** that is responsible for regulating the generator's voltage output. The voltage regulator kick-starts the cycle of converting AC current to AC voltage when the generator falls below its maximum operating level, and it settles into a state of equilibrium once the generator reaches its operating capacity.
-

7.1 Generator cont'd

- **Battery charger** reliable for generator to start up. The battery charger is responsible for keeping the battery charged by providing a float voltage of exactly 2.33 volts per cell.
 - **Control panel** located on the outside of the generator and contains multiple gauges and switches. Features can vary by generator, but the control panel typically includes a starter, engine control gauges and a frequency switch.
-

7.1.1 Types of Generators

- 13 Types of generators and their uses (13 Types of Generators and Their Uses, Dustin Eusebio, BigRentz, 2022.)
- Generators will help you to keep the lights ON and continue powering business operations, they can save the day in case of emergency.
- Different types of generators work best for different needs. Since powering a home is much different than powering an industrial-size business operation, it is very important to know different kinds of generators before purchasing.

Standby generators

- They create enough electricity to power an entire home, from lights to air conditioning and more. In case of a power outage, standby generators can turn ON automatically.
-

7.1.1 Types of Generators cont'd

Portable generators

- They are exactly what they sound like, portable. Unlike bulky standby generators, portable generators are small enough to take on a camping trip or store in the car for emergencies.
 - Because of their smaller size, portable generators don't produce enough electricity to power an entire house or construction site. But for charging cell phones on camping trips or powering electric tools, portable generators work perfectly. Mostly used in camping or traveling to locations without power.
-

7.1.1 Types of Generators cont'd

Inverter generators

- Inverter generators use a specialized process to create clean energy. Clean energy creates a more stable output than standard generators. This specialized process makes inverter generators quieter, more fuel-efficient and safer for charging sensitive electronics devices like laptops or phones.
 - They are available in a variety of sizes. Large inverters can power an entire home, mid-sized inverters can power an RV and small inverters can provide power on camping or boating trips.
 - The mechanics are different from other portable generators. In terms of currents, the power from the engine is a high-frequency AC. It's then converted into DC by the alternator. The generator has an inverter, which converts the current back to AC.
-

7.1.1 Types of Generators cont'd

Induction generators

- Induction generators work by creating electromagnetic fields that turn an internal rotor at varying speeds. In order to start this process, they require a large amount of mechanical energy which makes them most often used in wind turbines and mini hydro plants.
 - Their advantages are small sized, easy maintenance and ability to produce power at varying speeds. However, this speed variance creates unstable wattage outputs, which makes them a poor choice for home use.
 - They are best in generating power from large mechanical energy sources, like wind turbines or mini hydro plants.
-

7.1.1 Types of Generators cont'd

Industrial generators

- Industrial generators can operate much like any standard generator, but with a noticeable difference in size and durability. These generators are so large and they are often transported by crane. They can produce up to two megawatts of power and are made to withstand weather conditions, transportation and other strains found at industrial plants.

Gasoline generators

- Gasoline generators are popular for both at-home and commercial use because they tend to be affordable when compared to other generators. However, this may not be the case over the long term. Gas generators may be unreliable in emergency situations. Pumping gas requires electricity, so gasoline may be unavailable during power outages. They are best for construction sites on a budget with short-term projects.
-

7.1.1 Types of Generators cont'd

Natural gas generators

- Like gasoline generators, natural gas generators are initially cost-effective but may end up costing more overall with time. Natural gas generators connect to gas pipelines and they won't need to be refilled. However, connecting the generator to the pipelines means a higher installation and maintenance fee.
- Compared to gasoline and diesel generators, natural gas generators produce lower emissions. They are best for construction sites where environment friendly way is more required.

Diesel generators

- While initially more expensive than gasoline generators, diesel generators are usually more cost-effective over the long run. This is because diesel tends to be less expensive than gasoline, so maintenance cost is lower.
-

7.1.1 Types of Generators cont'd

- Winter diesel fuel can be used in cold weather to prevent freezing. This makes it a great option for those living in colder climates.
- On the downside, diesel faces similar accessibility problems as gasoline. If the power goes out, diesel pumps may stop working. They are best for construction sites in cold weather on long-term projects.

Biodiesel generators

- It is diesel generator more environmentally friendly. Biodiesel generators use a mixture of diesel and other components like vegetable oil or animal fat. This helps reduce the use of non-renewable fuel sources while producing lower emissions.
 - They may be unreliable in power outages where pumps are out of order.
-

7.1.1 Types of Generators cont'd

Emulsified diesel generators

- Emulsified diesel generators run on a mixture of diesel and water, making them even more environmentally friendly than biodiesel generators.

These generators face similar advantages and disadvantages as diesel and biodiesel generators. They are a cost-effective option in the long run and produce lower emissions.

Propane generators

- They run on propane are highly reliable. Propane is readily available, even in an outage. It's also easy to store propane and it runs well in cold weather even if the power goes out in the dead of winter, a propane generator can reliably start up and provide power. Since propane burns about three times faster than diesel generators, they are expensive. They are also highly flammable and should be handled with care.
-

7.1.1 Types of Generators cont'd

Solar generators

- Solar generators work by converting energy from the sun into usable electricity. They are a great option for eco-friendly shoppers as they produce no emissions and work with a renewable energy source. Because solar generators produce no emissions, they are safe for indoor use.
 - However, solar generators aren't always reliable for emergency use. If the power goes out at nighttime or there is no access to the sun, solar generators won't help. Additionally, these generators tend to be very expensive.
-

7.1.1 Types of Generators cont'd

Hydrogen generators

- Hydrogen generators convert water to hydrogen gas using electrolysis. This hydrogen gas is then burned to produce electricity. Hydrogen generators are tough, very eco-friendly and produce more energy per pound than any other fuel.
 - Because of their efficiency and reliability, they are a great choice across the board, including in homes, businesses, laboratories, industrial plants or farm. Portable hydrogen generators can even be used in cars.
 - Best for: Eco-friendly construction teams looking to cut down on electricity costs; those in need of a reliable emergency power source.
-

7.1.1 Types of Generators cont'd

Which Generators Are Most Emergency-Ready?

Fuel	Works Day/Night	Cold Resistant	Available in Outage
Gas			
Natural Gas			
Diesel			
Biodiesel			
Emulsified Diesel			
Propane			
Solar			
Hydrogen			

What Generators Are The Most Eco-friendly?

Key

- Fossil fuel emissions
- No emissions
- Nonrenewable fuel source components
- Renewable fuel source components

Fuel	Emissions	Renewable or Nonrenewable
Gas		
Natural Gas		
Diesel		
Biodiesel		
Emulsified Diesel		
Propane		
Solar		
Hydrogen		

13 Types of Generators and Their Uses, Dustin Eusebio, BigRentz, 2022.

7.1.1 Types of Generators cont'd

- **Based on output voltage:**
 - **Alternating Current (AC) Generators** are the most common type, producing electricity that fluctuates in direction, **Induction Generators** are widely used in wind turbines and hydroelectric power plants and **Synchronous Generators** are used in power plants and large industrial facilities.
 - **Based on portability:**
 - **Portable Generators** are smaller and lightweight, ideal for outdoor use or emergency backup, **Standby Generators** are larger and more powerful, designed to provide backup power for homes or businesses and **Industrial Generators** are very large and powerful, used in factories and other industrial facilities.
-

7.1.1 Types of Generators cont'd

- **Based on fuel source:**
 - **Gasoline Generators** are portable and versatile, often used for recreational activities and emergency backup, **Diesel Generators** are more powerful and fuel-efficient than gasoline generators, commonly used in industrial settings, **Natural Gas Generators** are clean-burning and efficient, often used for standby power in homes and businesses, **Propane Generators** are portable and efficient, similar to gasoline generators but using propane as fuel and **Solar Generators** convert sunlight into electricity using solar panels.
 - **Other types:**
 - **Wind Generators** convert wind energy to electricity, **Hydroelectric Generators:** convert water energy to electricity, **Geothermal Generators:** convert heat from the Earth's interior to electricity. (Understanding Electrical Power Systems, William Stevenson, McGraw-Hill Education, 2016.)
-

7.1.2 Working principle of a generator

- Generators are useful appliances that supply electrical power during a power outage and prevent discontinuity of daily activities or disruption of business operations.
 - Generators are available in different electrical and physical configurations for use in different applications. The working of generator as a secondary source of electrical power in residential and industrial applications is provided:
 - An electric generator is a device that converts mechanical energy obtained from an external source into electrical energy as the output.
 - It is important to understand that a generator does not actually 'create' electrical energy. Instead, it uses the mechanical energy supplied to it to force the movement of electric charges present in the wire of its windings through an external electric circuit.
-

7.1.2 Working principle of a generator

- This flow of electric charges constitutes the output electric current supplied by the generator. This mechanism can be understood by considering the generator to be analogous to a water pump, which causes the flow of water but does not actually 'create' the water flowing through it.
- The modern-day generator works on the principle of electromagnetic induction discovered by Michael Faraday in 1831-32 stating that the flow of electric charges could be induced by moving an electrical conductor, such as a wire that contains electric charges, in a magnetic field.
- This movement creates a voltage difference between the two ends of the wire or electrical conductor, which in turn causes the electric charges to flow, thus generating electric current.

https://www.generatorsource.com/How_Generators_Work.aspx

7.1.3 Applications of generators

- Generators are used in many applications as their types have also shown.
- The following list provides the information related to where generators are applied, and the applications may vary from type to type depending on the application requirements.
- Emergencies, Routine power outages, Standby power for businesses, Camping, Construction, Mining, Agriculture and Ranching, Night working, Fairs and Carnivals, Family reunions, Weddings, Cookouts, Holiday displays, Sporting events, Tailgating, Boating.

[\(https://www.wpowerproducts.com/blog/generator-applications/14-practical-uses-for-generators/\)](https://www.wpowerproducts.com/blog/generator-applications/14-practical-uses-for-generators/)

7.2. UPS

- A UPS is a device that provides backup power to electrical equipment when the main power source fails. Its importance is to protect against power outages, to ensure continuous operation of critical equipment and to safeguard data integrity.
 - In addition to supplying emergency electrical power to the loads, a UPS also protects sensitive equipment such as computers, data centers, TV sets, industrial process control and monitoring systems, and many other electronic devices.
-

7.2.1 Components of a UPS

Major Parts of an UPS

- **Battery** works as the energy storage unit in the UPS system. It provides the stored electrical energy for enough time during main power failure.
- **Rectifier or charger circuit** converts the supply voltage of 240 VAC into 12 V (or any other battery voltage) DC. It supplies this rectified DC power to the battery for storage.
- **Inverter** converts the DC output power of the battery into ac power to supply the load during mains power failure.
- **Static switch** is a semiconductor device such as a thyristor which transfers the load from the utility to the inverter (and the inverter to the utility) without any interruption in the power supply to the load.

<https://www.tutorialspoint.com/uninterruptible-power-supply-ups-definition-block-diagram-types-and-applications>

7.2.2 Working principle of a UPS

- When there is any failure in the main power supply from the utility, the UPS supplies emergency power to the load for a short duration of time.
 - This is the primary function of a UPS. Modern UPSs can also provide protection against electrical faults such as short-circuit, voltage fluctuations, low voltage, instability of mains frequency, etc.
 - **Normal operation**, gets power from mains and charges the battery then powers the connected load.
 - **Power failure**, UPS switches to battery mode, using the inverter to supply power to the load.
 - **Restoration**, UPS reverts to charging the battery once mains power is restored
-

7.2.3 Types of UPS

- **Offline/Standby UPS** is a basic level of backup; switches on when power fails. This type of UPS system gives only the most basic features. In the case of off-line UPS, the system will start operating only when there is a power failure in the supply mains.
 - **Online UPS** that provides continuous power with no switching time; ideal for sensitive equipment. This system uses a double conversion method where the input AC power is first converted into DC power by a rectifier to charge the UPS battery, and then this DC power is converted back into AC power by a power inverter to power the load equipment. Commonly used in such systems where electrical isolation is required between the input and output.
-

7.2.3 Types of UPS

- **Line-Interactive UPS** which provides voltage regulation; better for fluctuating power. The system is connected in parallel with the AC mains in a standby configuration so that these systems can interact with the AC input system. These types are mainly used in small businesses and offices.

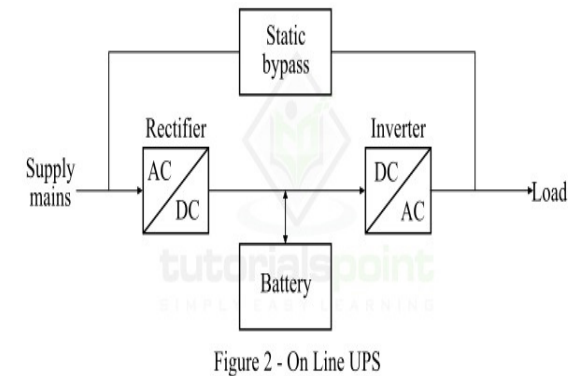
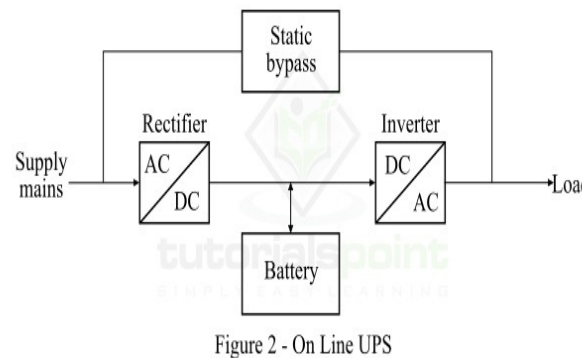
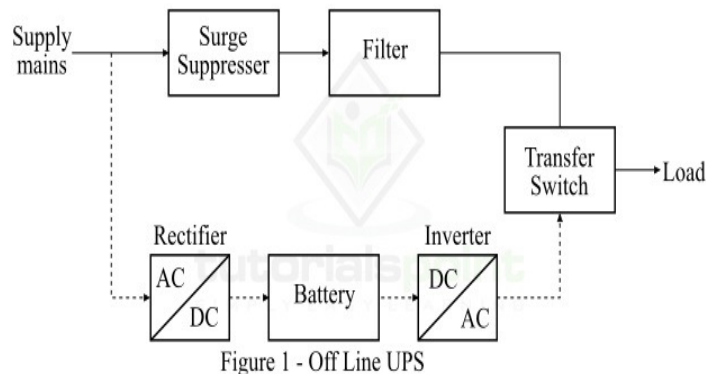

(<https://www.tutorialspoint.com/uninterruptible-power-supply-ups-definition-block-diagram-types-and-applications>)

7.2.3 Types of UPS

When the mains supply fails, the switch will automatically cut off the power from it and supply power to the load from the inverter circuit.

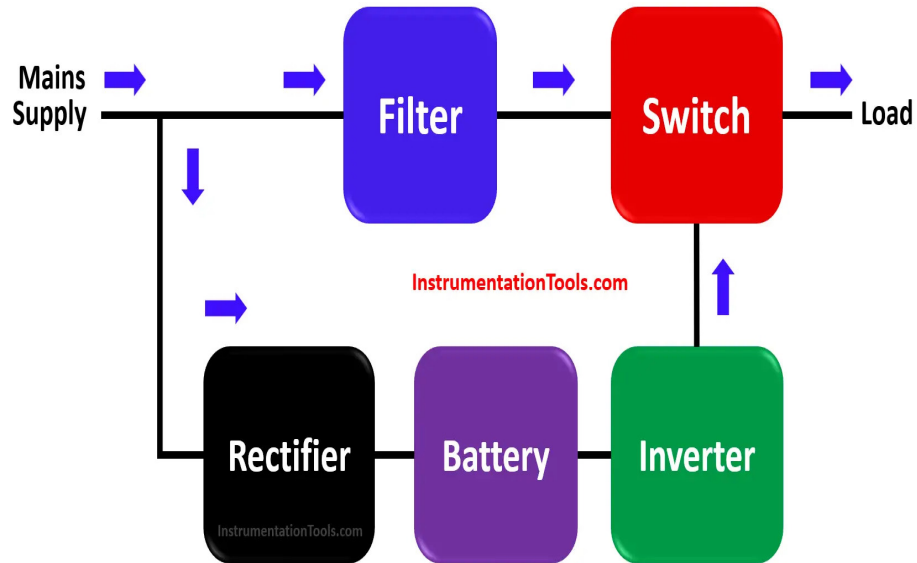

When the main supply fails, the battery will automatically supply power to the inverter. The rectifier will be bypassed in this case.

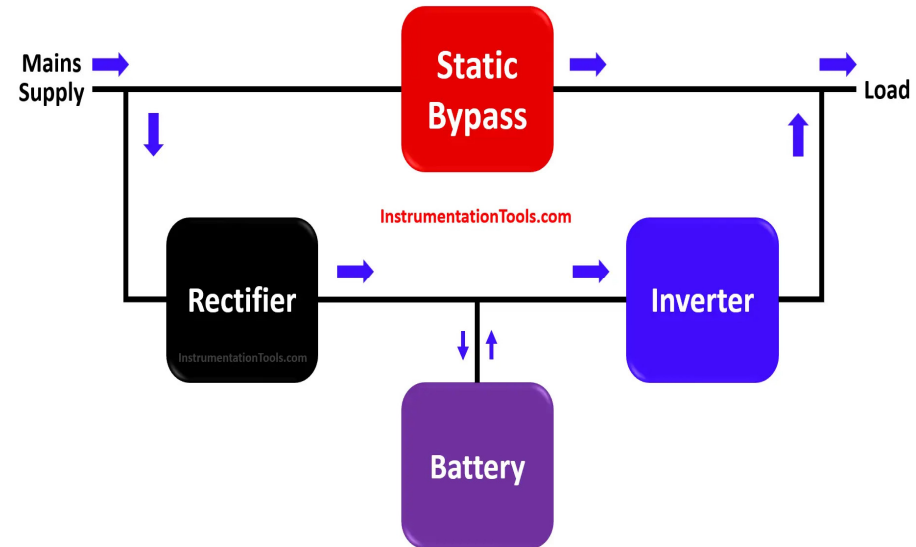

[\(https://instrumentationtools.com/ups-working-principle-types-offline-online/\)](https://instrumentationtools.com/ups-working-principle-types-offline-online/)

7.2.4 Applications and advantages of UPS

- Data centers: Maintains operations of servers and networking equipment.
 - Medical facilities: Ensures critical equipment remains operational.
 - Telecommunications: Keeps communication systems running during outages.
 - Industrial applications: Protects machinery and controls.
 - Power continuity: Protects against power outages.
 - Surge protection: Shields equipment from voltage spikes.
 - Data integrity: Prevents data loss in computers and servers.
 - Scalability: Can be expanded with additional batteries or modules.
-

Additional notes on UPS

Some limitations are:

- Battery Life: Limited lifespan of batteries requires regular replacement.
- Cost: Higher upfront costs for more advanced systems.
- Maintenance: Requires periodic testing and maintenance for reliability.

New trends are:

- Smart UPS: Integration with IoT for monitoring and control.
 - Energy storage solutions: Advances in battery technology, like solid-state batteries.
 - Renewable integration: UPS systems designed to work with solar and wind energy.
 - In summary the benefits are data loss prevention , hardware protection and downtime reduction.
-

Thank you for your good attention
Q&A

References

- Electrical Equipment, B Koti Reddy, Indian Institute of Technology Hyderabad, 2021.
 - Infrastructure - DELTA - DELTA Power Solutions, Delta Power Solutions, 2024.
 - 13 Types of Generators and Their Uses, Dustin Eusebio, BigRentz, 2022.
 - Understanding Electrical Power Systems, William Stevenson, McGraw-Hill Education, 2016.
 - How Do Generators Work?, Dustin Eusebio, BigRentz, 2021.
 - How Do Generators Work?, Generator Source, 2021.
-

References cont'd

- 14 Practical Uses for Generators, Worldwide Power Products, 2023.
 - Uninterruptible Power Supply (UPS): Definition, Block Diagram, Types, and Applications, TutorialsPoint, 2024.
 - UPS Working Principle and Types – Offline and Online UPS Systems, Viral Nagda, Instrumentation Tools, 2023.
-