

Engineering Thermodynamics I

Lecture 14

Refrigeration Cycles

Lecturer: Dr. Melaku Desta

Lecture learning outcomes:

At the end of this lecture, you will be able to:

- i. Understanding the fundamental principles, processes, and efficiency of the ideal vapor compression refrigeration cycle under perfect conditions.
- ii. Learn to evaluate system performance using thermodynamic laws and energy balance equations.
- iii. Identify deviations from the ideal cycle due to inefficiencies like pressure drops, heat losses, and non-ideal compressor behavior.
- iv. Analyze the differences between vapor compression and vapor absorption refrigeration cycles in working principles, energy sources, and practical applications.
- vi. Discover methods to enhance refrigeration cycle performance, including component optimization and alternative refrigerants.

Content

1. Vapor Compression Refrigeration Cycle
2. Ideal Vapor Compression Refrigeration Cycle
3. Energy Analysis of Vapor Compression Refrigeration Cycle
4. Real Vapor Compression Refrigeration Cycle
5. Vapor Absorption Refrigeration Cycle

Summary

References

1. Vapor Compression Refrigeration Cycle

- Reversed Carnot cycle is **not a suitable model** for refrigeration cycle
 1. Involves the **compression of a liquid-vapor mixture**, which requires a compressor that will **handle two phase**.
 2. Involves the expansion of **high-moisture-content** refrigerant in a turbine
 - **It consists two reversible isothermal and two isentropic processes.**

For the Carnot refrigeration cycle

$$COP_R = \frac{1}{Q_H/Q_L - 1}$$

1. Vapor Compression Refrigeration Cycle

Cont...

- Replacing **Heat transfer ratios** by the ratios of the **absolute temperatures** of the high and low temperature reservoirs

$$COP_{R,Rev} = \frac{1}{T_H/T_L - 1}$$

- It is the **maximum theoretical value** for the specified **temperature limits**.
- Actual COP may **approach this values** as the **design is improved**, but it can **never reach**.

2. Ideal Vapor Compression Refrigeration Cycle

- The ideal vapor compression refrigeration cycle is the most widely used refrigeration system [1] and,
- It consists of four processes
 - **Isentropic** compression in a compressor
 - **Constant-pressure** heat rejection in a condenser
 - **Throttling** in an expansion device
 - **Constant-pressure** heat absorption in an evaporator

2. Ideal Vapor Compression Refrigeration Cycle

Cont...

Working Principle of VCR Cycle

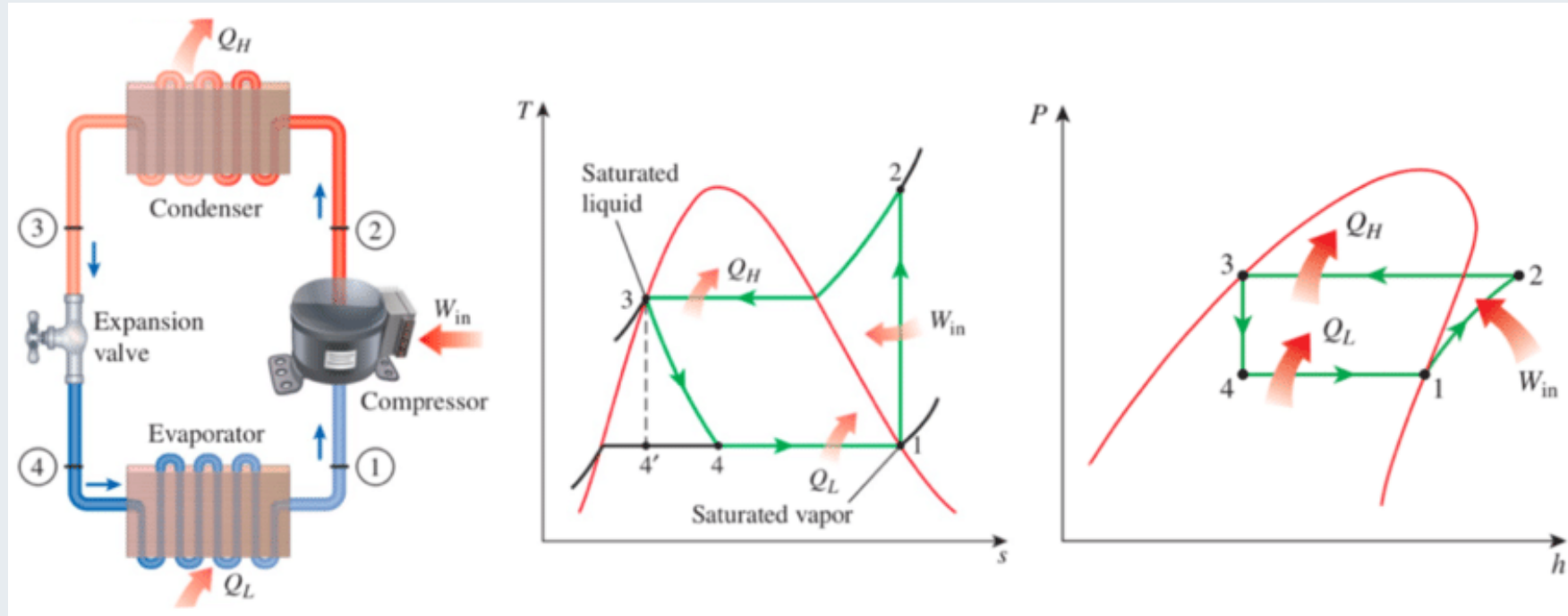

Figure 1: Schematic diagram, T-s diagram and P-h diagram of an Ideal Vapor-Compression Refrigeration cycle

[url: https://www.researchgate.net/publication/326912104/figure/fig2/AS:657525586272256@153377724722/a-b-c-Schematic-and-T-s-diagram-for-the-ideal-vapor-compression-refrigeration-cycle.png](https://www.researchgate.net/publication/326912104/figure/fig2/AS:657525586272256@153377724722/a-b-c-Schematic-and-T-s-diagram-for-the-ideal-vapor-compression-refrigeration-cycle.png)

3. Energy Analysis of Vapor Compression Refrigeration Cycle

Energy Analysis of Vapor Compression Refrigeration Cycle

- The general energy balance equation for open systems from the First law of thermodynamics is:

$$Q_{in} + W_{in} + \sum_{in} m \left(h_i + \frac{V_i^2}{2} + gz_i \right) = Q_{out} + W_{out} + \sum_{out} m \left(h_e + \frac{V_e^2}{2} + gz_e \right)$$

- The energy analysis for the components of the vapor compression refrigeration cycle, i.e., **compressor, condenser, expansion valve** and **evaporator** are derived below:

3. Energy Analysis of Vapor Compression Refrigeration Cycle

Cont...

$$Q_{in} + W_{in} + \sum_{in} m \left(h_i + \frac{V_i^2}{2} + gz_i \right) = Q_{out} + W_{out} + \sum_{out} m \left(h_e + \frac{V_e^2}{2} + gz_e \right)$$

1. Compressor Work input (\dot{W}_{in}):

The compressor increases the refrigerant's pressure and temperature.

$$\dot{W}_{in} = \dot{m}(h_2 - h_1)$$

2. Heat rejected in condenser (\dot{Q}_H)

$$\dot{Q}_H = \dot{m}(h_2 - h_3)$$

3. Expansion Valve (Throttling Process)

$$h_3 = h_4$$

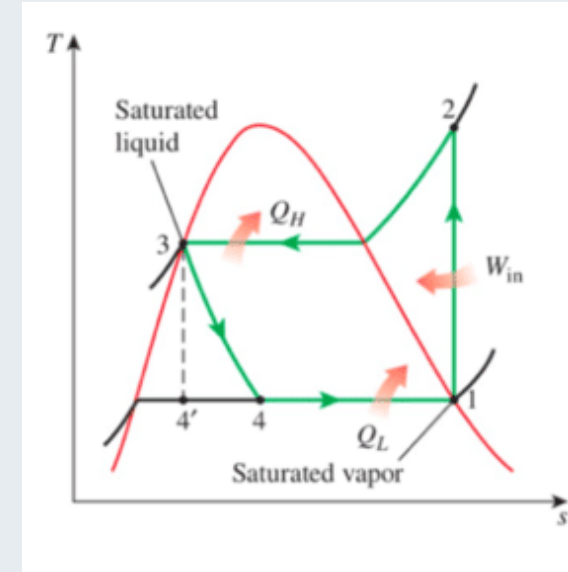

3. Energy Analysis of Vapor Compression Refrigeration Cycle

Cont...

$$Q_{in} + W_{in} + \sum_{in} m \left(h_i + \frac{V_i^2}{2} + gz_i \right) = Q_{out} + W_{out} + \sum_{out} m \left(h_e + \frac{V_e^2}{2} + gz_e \right)$$

4. Heat Absorbed in Evaporator (\dot{Q}_L)

$$\dot{Q}_L = \dot{m}(h_1 - h_4)$$

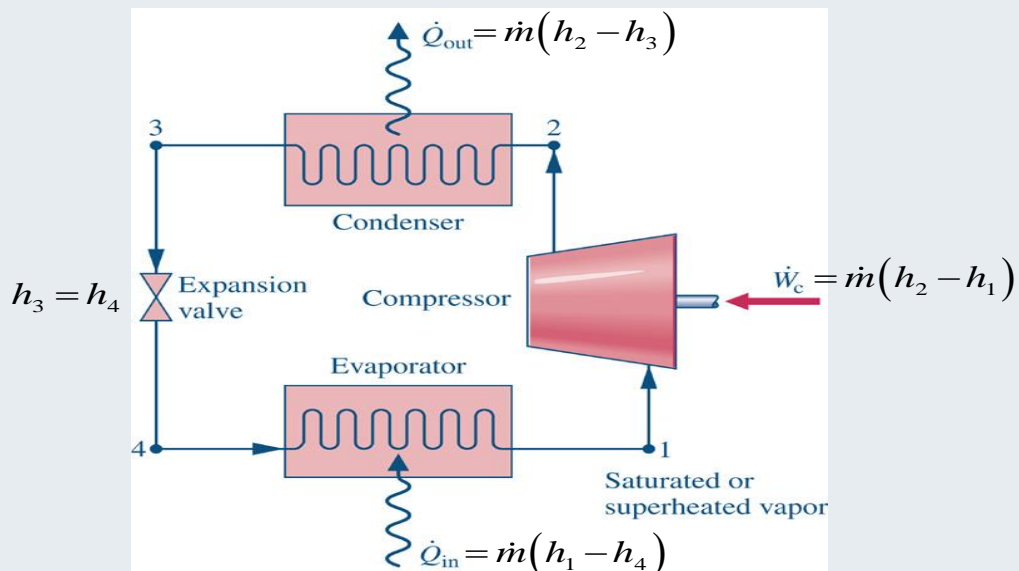

Figure 2: Schematic diagram of a Vapor-Compression Refrigeration cycle

[url: https://media.cheggcdn.com/media/568/568247de-742f-400f-b91f-8e0eb94052d5/php5lxL8G.png](https://media.cheggcdn.com/media/568/568247de-742f-400f-b91f-8e0eb94052d5/php5lxL8G.png)

3. Energy Analysis of Vapor Compression Refrigeration Cycle

Cont...

The coefficient of performance of the system becomes:

$$COP = \frac{\text{Useful Thermal Energy Transferred}}{\text{Work Input}}$$

The coefficient of performance of a **refrigerator** becomes:

$$COP_R = \frac{\text{Heat absorbed from cold space } (Q_L)}{W_{net,in}} = \frac{Q_L}{W_{net,in}} = \frac{h_1 - h_4}{h_2 - h_1}$$

And, the coefficient of performance of a **heat pump** becomes:

$$COP_{HP} = \frac{\text{Heat delivered to warm space } (Q_H)}{W_{net,in}} = \frac{Q_H}{W_{net,in}} = \frac{h_2 - h_3}{h_2 - h_1}$$

Refrigeration effect and capacity

- The **refrigeration effect** and **refrigeration capacity** are two key parameters that define the performance of a vapor compression refrigeration system [2].

1. Refrigeration Effect (Cooling Effect per Unit Mass)

- It is the amount of heat absorbed by the refrigerant in the evaporator per unit mass of refrigerant circulated.

$$\text{Refrigeration Effect: } q_{in} = h_1 - h_4$$

3. Energy Analysis of Vapor Compression Refrigeration Cycle

Cont...

2. Refrigeration Capacity (Total Cooling Power)

- It is the rate at which heat is absorbed in the evaporator, representing the system's cooling power.

$$\text{Refrigeration Capacity: } \dot{Q}_{in} = \dot{m}(h_1 - h_4)$$

- Refrigeration capacity is often expressed in **tons of refrigeration**.
- 1 ton of refrigeration is the steady state heat transfer rate required to melt 1 ton of ice at 32°F in 24 hours [3].

$$1 \text{ ton} = 12,000 \text{ Btu/hr} = 3.516 \text{ kW}$$

Factors Affecting Refrigeration Effect & Capacity

1. Evaporator Pressure/Temperature

- Lower evaporator temperature reduces h_1 , decreasing refrigeration effect.

2. Condenser Pressure/Temperature

- Higher condenser pressure increases h_4 , reducing refrigeration effect.

3. Refrigerant Type

- Different refrigerants (R-134a, R-404A, Ammonia) have varying enthalpy values.

3. Energy Analysis of Vapor Compression Refrigeration Cycle

Cont...

Factors Affecting Refrigeration Effect & Capacity

4. Subcooling & Superheating

- Subcooling in the condenser increases h_4 , improving refrigeration effect.
- Excessive superheating may reduce system efficiency.

5. Compressor Efficiency

- Inefficient compression reduces mass flow rate (\dot{m}), lowering capacity.

3. Energy Analysis of Vapor Compression Refrigeration Cycle

Cont...

Example:

A refrigerator uses R-134a as the working fluid and operates on an ideal vapor-compression cycle between 0.14 MPa (evaporator pressure) and 0.8 MPa (condenser pressure). The refrigerant mass flow rate is 0.06 kg/s. Determine

- a. the rate of heat removal from the refrigerated space
- b. the power input to the compressor,
- c. the rate of heat rejection to the environment, and
- d. the coefficient of performance.

3. Energy Analysis of Vapor Compression Refrigeration Cycle

Cont...

Solution:

- Evaporator Pressure, $P_1 = 0.14 \text{ MPa}$
- Condenser Pressure, $P_2 = 0.8 \text{ MPa}$
- Mass flow rate = 0.06 kg/s

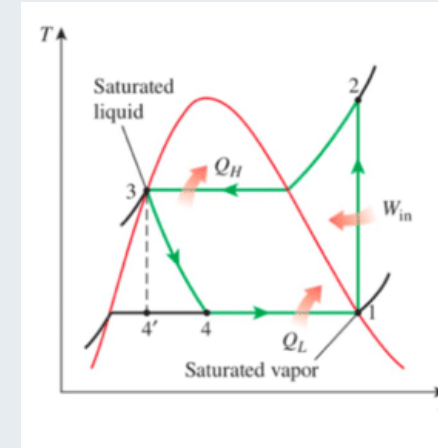

State 1: Evaporator Exit (Saturated Vapor) , $h_1 = 236.04 \text{ kJ/kg}$, $s_1 = 0.9322 \text{ kJ/kg K}$

State 2: Compressor Exit, from superheated R-134a Table at $P_2 = 0.8 \text{ MPa}$ and

$s_2 = s_1 = 0.9322 \text{ kJ/kgK}$,then $h_2 = 272.05 \text{ kJ/kg}$

State 3: Condenser Exit (Saturated Liquid)

$P_3 = 0.8 \text{ MPa}$, then $h_3 = 93.42 \text{ kJ/kg}$

3. Energy Analysis of Vapor Compression Refrigeration Cycle

Cont...

State 4: Throttling Valve Exit (Isenthalpic Expansion)

$$P_4 = 0.14 \text{ MPa},$$

$$h_4 = h_3 = 93.42 \text{ kJ/kg}$$

a) Rate of heat removal from refrigerated space (\dot{Q}_L)

$$\dot{Q}_L = \dot{m} \times (h_1 - h_4)$$

$$\dot{Q}_L = 0.06 \times (236.04 - 93.42) = 8.557 \text{ kW}$$

(b) Power input (\dot{W}_{in})

$$\dot{W}_{in} = \dot{m} \times (h_2 - h_1)$$

$$\dot{W}_{in} = 0.06 \times (272.05 - 236.04) = 2.161 \text{ kW}$$

3. Energy Analysis of Vapor Compression Refrigeration Cycle

Cont...

Rate of heat rejection to the environment (\dot{Q}_H)

$$\dot{Q}_H = \dot{m} \times (h_2 - h_3)$$

$$\dot{Q}_H = 0.06 \times (272.05 - 93.42) = 10.718 \text{ Kw}$$

Coefficient of Performance (COP)

$$COP = \frac{\dot{Q}_L}{\dot{W}_{in}} = \frac{8.557}{2.161} = 3.96$$

4. Real Vapor Compression Refrigeration Cycle

- While the **ideal cycle** assumes no losses, the **actual cycle** includes real-world inefficiencies such as pressure drops, irreversibilities, and non-isentropic compression.
- Understanding these deviations is essential for improving system performance.

What are the deviations from the Ideal Cycle?

- In reality, several factors affect the cycle's efficiency:

1. Non-Isentropic Compression:

- Due to mechanical inefficiencies and heat transfer, the compressor consumes more power than theoretically required.

4. Real Vapor Compression Refrigeration Cycle

Cont...

$$\text{Isentropic Efficiency, } \eta_c = \frac{h_{2s} - h_1}{h_{2a} - h_1}$$

2. Pressure Drops:

- Friction losses in pipes and heat exchangers reduce the system's efficiency.

3. Superheating & Subcooling:

- These processes affect performance by changing refrigerant properties before compression and expansion.

4. Heat Losses:

- Some heat exchange occurs with the environment, affecting cooling efficiency

4. Real Vapor Compression Refrigeration Cycle

Cont...

Modified T-s diagram for real vapor compression refrigeration cycle:

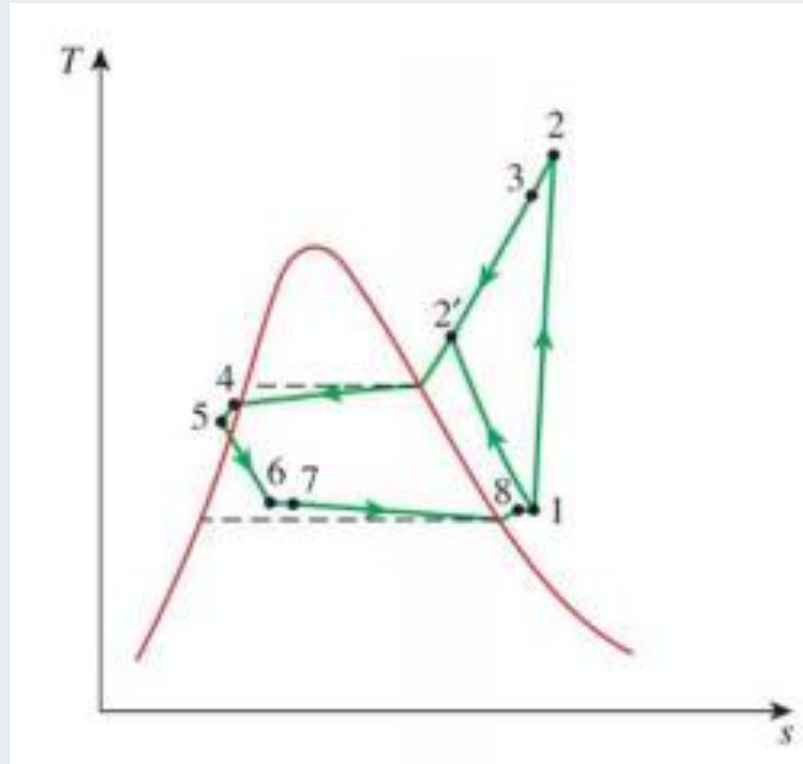

Figure 3: T-s diagram of the Real Vapor Compression Refrigeration cycle

[url: https://media.cheggcdn.com/media/ab4/ab46b443-b47a-41ad-a8e8-589a5ef9a086/phpjKWlWu](https://media.cheggcdn.com/media/ab4/ab46b443-b47a-41ad-a8e8-589a5ef9a086/phpjKWlWu)

4. Real Vapor Compression Refrigeration Cycle

Cont...

Modified P-h diagram for real vapor compression refrigeration cycle:

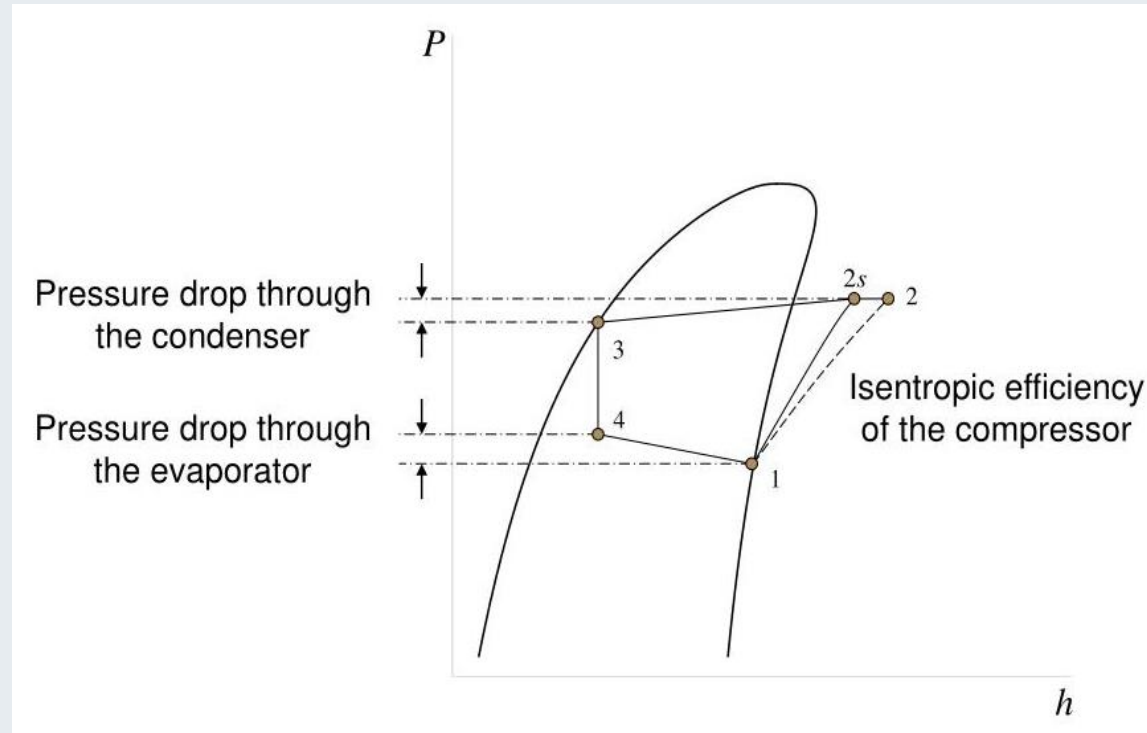

Figure 4: P-h diagram of the Real Vapor Compression Refrigeration cycle
[url: https://image3.slideserve.com/6698726/vcr-cycle-irreversibilities-1.jpg](https://image3.slideserve.com/6698726/vcr-cycle-irreversibilities-1.jpg)

4. Real Vapor Compression Refrigeration Cycle

Cont...

Example

A refrigeration system using R-134a as the refrigerant operates on an actual vapor compression cycle under the following conditions:

- Evaporator pressure, $P_1 = 120 \text{ kPa}$
- Condenser pressure, $P_2 = 800 \text{ kPa}$
- Refrigerant mass flow rate, $\dot{m} = 0.05 \text{ kg/s}$
- Compressor isentropic efficiency, $\eta_c = 80\%$
- Refrigerant enters the compressor as saturated vapor.
- Refrigerant leaves the condenser as saturated liquid.

Determine:

- Compressor work input (W_{in})
- Refrigeration effect (Q_L)
- Coefficient of Performance (COP)

4. Real Vapor Compression Refrigeration Cycle

Cont...

Solution:

State 1: Saturated vapor at 120 kPa, from R-134a Saturation Table

$$h_1 = h_{g@120kPa} = 236.04 \text{ kJ/kg}, \text{ and } s_1 = s_{g@120kPa} = 0.9322 \text{ kJ/kgK}$$

State 2s: Isentropic Compression to 800 kPa (Ideal Case)

$$P_2 = 800 \text{ kPa and } s_{2s} = s_1 = 0.9322 \text{ kJ/kgK}$$

$$h_{2s} = 272.05 \text{ kJ/kg}$$

State 2a: Actual Compressor Exit

The actual compressor work is higher due to inefficiency:

$$\eta_c = \frac{h_{2s} - h_1}{h_{2a} - h_1} \quad \rightarrow \quad h_2 = h_1 + \frac{h_{2s} - h_1}{\eta_c}$$

$$h_{2a} = 236.04 + \frac{272.05 - 236.04}{0.8} = 281.05 \text{ kJ/kg}$$

4. Real Vapor Compression Refrigeration Cycle

Cont...

State 3: Condenser Exit (Saturated Liquid)

$$P_3 = 800 \text{ kPa}$$

From the saturation table for R-134a at 800 kPa

$$h_3 = 93.42 \text{ kJ/kg}$$

State 4: Throttling Valve Exit (Isenthalpic Expansion)

$$P_4 = 120 \text{ kPa}$$

$$h_3 = h_4 = 93.42 \text{ kJ/kg}$$

Compressor Work Input (\dot{W}_{in})

$$\dot{W}_{in} = \dot{m} \times (h_{2a} - h_1)$$

$$\dot{W}_{in} = 0.05 \times (281.05 - 236.04) = 2.25 \text{ kW}$$

4. Real Vapor Compression Refrigeration Cycle

Cont...

Refrigeration effect \dot{Q}_L :

$$\dot{Q}_L = \dot{m} \times (h_1 - h_4)$$

$$\dot{Q}_L = 0.05 \times (236.04 - 93.42) = 7.13 \text{ kW}$$

Coefficient of Performance (COP),

$$COP = \frac{\dot{Q}_L}{\dot{W}_{in}} = \frac{7.13}{2.25} = 3.17$$

To improve efficiency:

- **Using multi-stage compression** reduces work input.
- **Employing intercoolers and reheaters** improves thermodynamic performance.
- **Optimizing refrigerant selection** for environmental and efficiency considerations.

5. Vapor Absorption Refrigeration Cycle (VAR)

- The **Vapor Absorption Refrigeration Cycle (VAR)** is an alternative to the conventional vapor compression refrigeration cycle (VCR).
- Instead of using a mechanical compressor, it relies on **thermal energy (heat)** to drive the refrigeration process.
- Unlike vapor compression refrigeration (VCR) systems, the required input to absorption systems is in the form of **heat**.
- **VARs** are called heat operated or **thermal energy** driven systems.
- Widely used in various refrigeration and air conditioning applications [4].

5. Vapor Absorption Refrigeration Cycle

Cont...

- They are preferred when low-grade energy such as **waste heat** or **solar energy** is available.
- Since conventional absorption systems use natural refrigerants such as water or ammonia they are environment friendly [5].
- **VAR** differ from VCR **only** in the **method of compressing** the refrigerant
- **Compressor** is **replaced** by three main elements
 - an absorber,
 - a solution pump, and
 - a generator.

5. Vapor Absorption Refrigeration Cycle

Cont...

The components of VAR

Component	Function
Absorber	Absorbs refrigerant vapor into the absorbent (e.g., NH_3 in H_2O).
Pump	Increases pressure of the liquid solution ($\text{NH}_3 + \text{H}_2\text{O}$).
Generator	Uses heat to separate refrigerant (NH_3) from the absorbent (H_2O).
Condenser	Condenses high-pressure refrigerant vapor into liquid.
Expansion Valve	Reduces pressure of the refrigerant before evaporation.
Evaporator	Absorbs heat from the cooling space, turning liquid refrigerant into vapor.

5. Vapor Absorption Refrigeration Cycle

Cont...

The difference between VCR and VAR

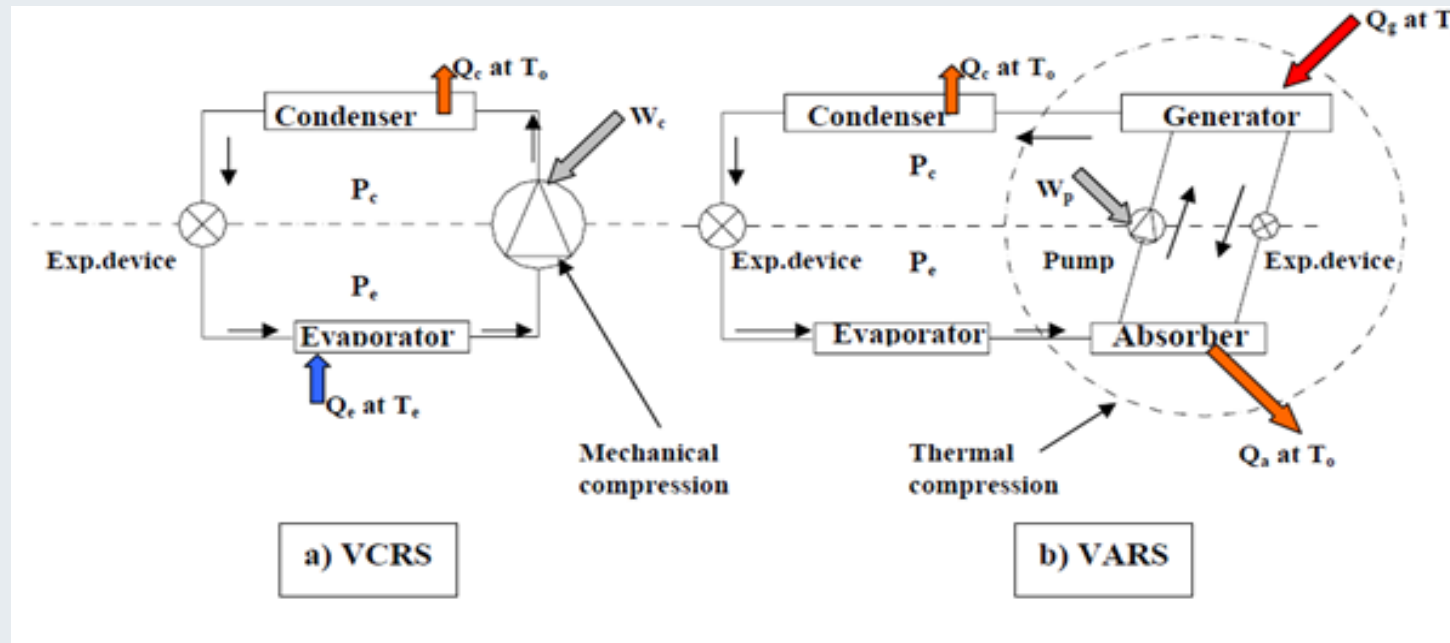

Figure 5: The differences between VCR and VAR

[url: https://ecampusontario.pressbooks.pub/app/uploads/sites/3587/2023/10/comparisons-300x175.png](https://ecampusontario.pressbooks.pub/app/uploads/sites/3587/2023/10/comparisons-300x175.png)

5. Vapor Absorption Refrigeration Cycle

Cont...

- The VAR operates based on the principle of **absorbing refrigerant vapor into an absorbent**, then releasing it using heat.
- 1. The most **widely used system** is the **Ammonia–Water** system
 - Ammonia (NH_3) serves as the refrigerant and
 - Water (H_2O) as the transport medium
- 2. **Water–Lithium Bromide** and
 - Water serves as the refrigerant
- 3. **Water–Lithium Chloride** systems
 - Water serves as the refrigerant

5. Vapor Absorption Refrigeration Cycle

Cont...

The working principle of Ammonia (NH_3) –Water (H_2O) VAR systems

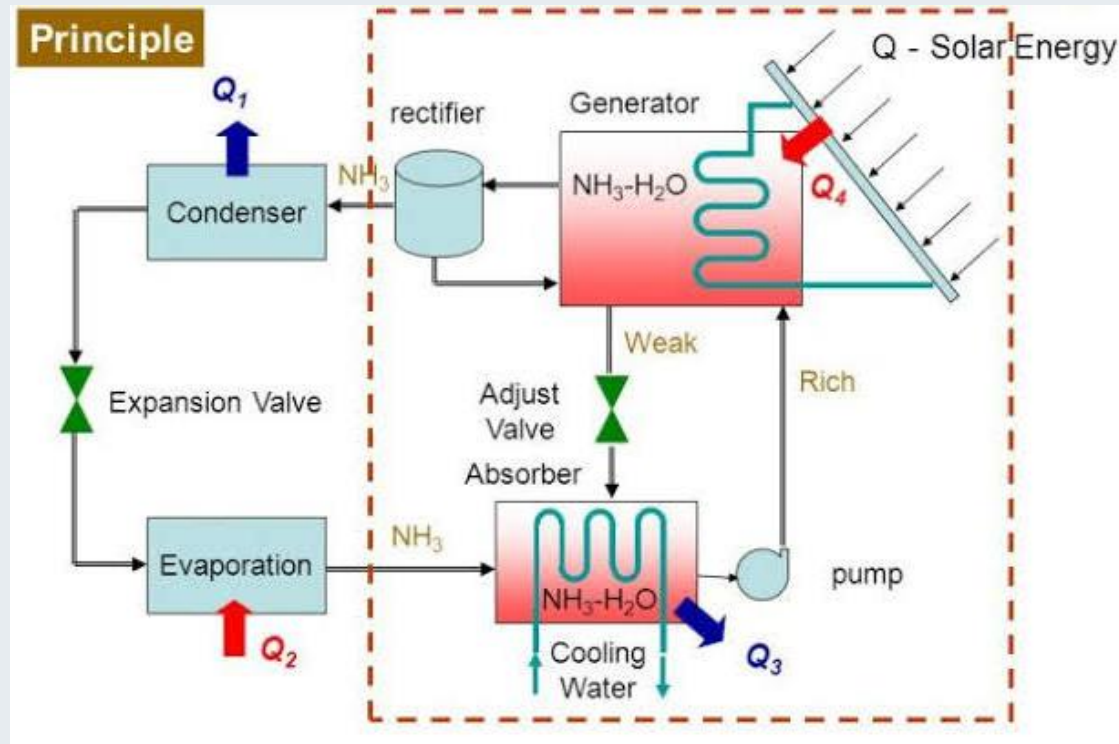

Figure 6: Working principle of Ammonia-Water VAR System

[url: https://encrypted-tbn1.gstatic.com/images?q=tbn:ANd9GcSMr71cw7swRUZQV8jdzh2_sMnx2PMamdfEzEsW9jjMoj2xLZJG](https://encrypted-tbn1.gstatic.com/images?q=tbn:ANd9GcSMr71cw7swRUZQV8jdzh2_sMnx2PMamdfEzEsW9jjMoj2xLZJG)

5. Vapor Absorption Refrigeration Cycle

Cont...

The working principle of $\text{NH}_3 + \text{H}_2\text{O}$ VARC

Step 1: Absorption

- Refrigerant vapor (NH_3) from the evaporator is absorbed by a weak absorbent (H_2O) in the absorber.
- This forms a strong solution ($\text{NH}_3 + \text{H}_2\text{O}$) and releases heat, which is removed by cooling water.

Step 2: Pumping

- The pump increases the pressure of the strong solution and sends it to the generator.

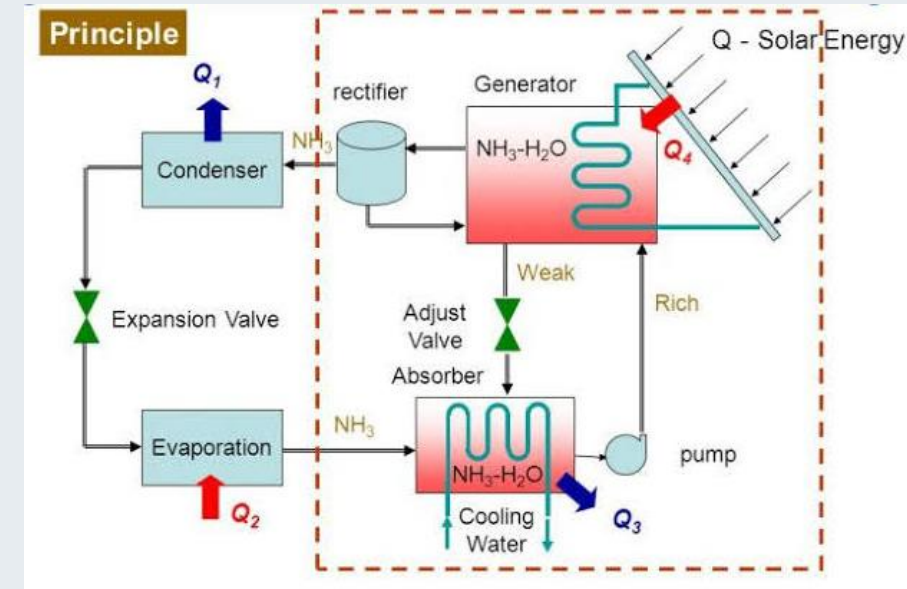

5. Vapor Absorption Refrigeration Cycle

Cont...

Step 3: Generation (Desorption)

- In the generator, heat (from steam, waste heat, or solar energy) is supplied to separate NH_3 vapor from H_2O .
- The weak solution (H_2O) returns to the absorber via a pressure-reducing valve.

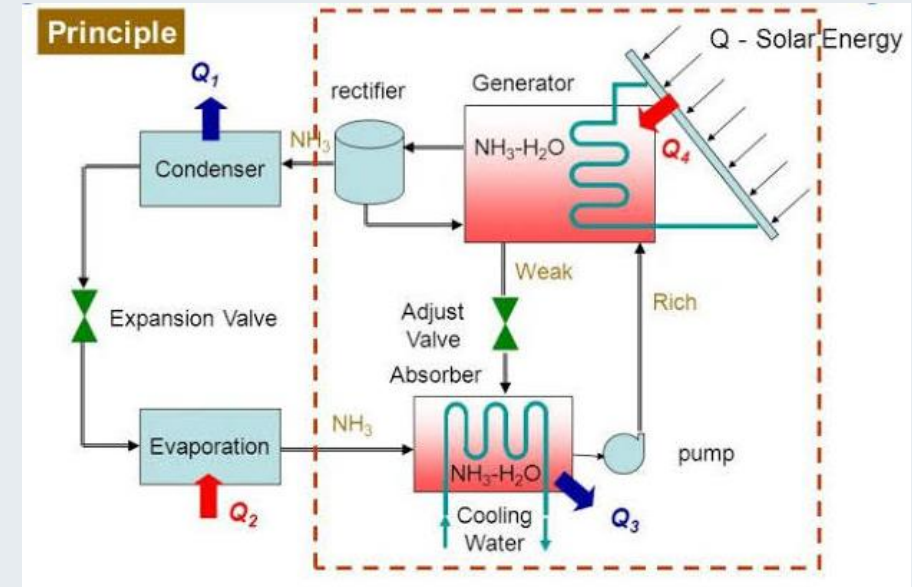

Step 4: Condensation

- The high-pressure NH_3 vapor moves to the condenser, where it rejects heat and condenses into liquid NH_3 .

5. Vapor Absorption Refrigeration Cycle

Cont...

Step 5: Expansion & Evaporation

- Liquid NH_3 passes through an expansion valve, reducing its pressure and temperature
- In the evaporator, it absorbs heat from the refrigerated space, turning back into vapor.

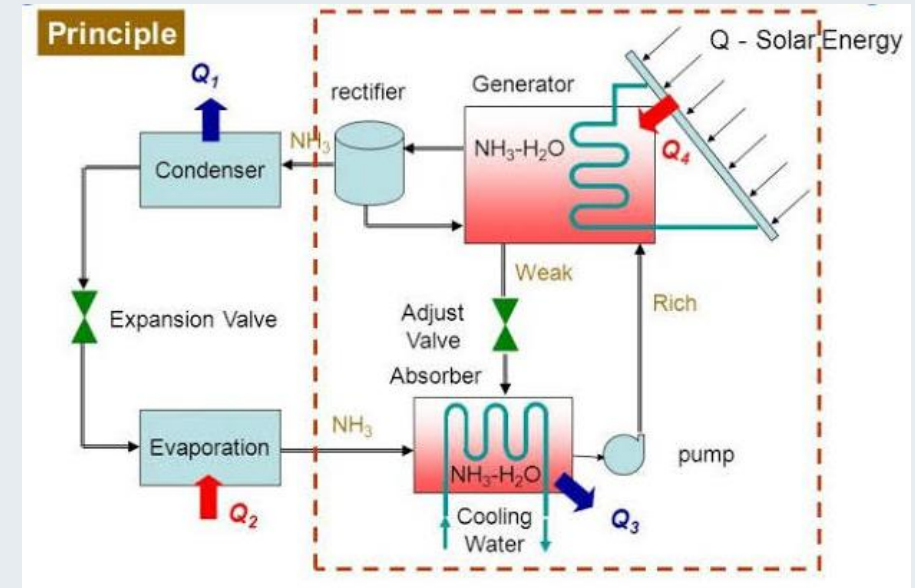

5. Vapor Absorption Refrigeration Cycle

Cont...

Advantages of VAR

- No moving parts (except pump) → Less maintenance.
- Can use waste heat/solar energy → Energy-efficient.
- Environmentally friendly (uses natural refrigerants like NH_3).

Disadvantages of VAR

- Lower COP compared to VCR.
- Bulky system (requires absorber, generator, etc.).
- Corrosion issues (especially with LiBr systems).

5. Vapor Absorption Refrigeration Cycle

Cont...

Performance Evaluation of Vapor Absorption Refrigeration Cycles

- The solution pump work is often negligible compared to the generator heat input.
- Thus the COPs for compression and absorption systems are given by:

$$COP_{VCR} = \frac{Q_E}{W_{in}}$$

$$COP_{VAR} = \frac{Q_E}{Q_G + W_P} \approx \frac{Q_E}{Q_G}$$

5. Vapor Absorption Refrigeration Cycle

Cont...

Comparison of Coefficient of Performance of VCR and VAR

- The COP of VCRs will be **much higher** than the COP of VARs as a high grade mechanical energy is used in the former, while a low-grade thermal energy is used in the latter.
- However, comparing these systems based on COPs is not fully justified, as mechanical energy is more expensive than thermal energy.

5. Vapor Absorption Refrigeration Cycle

Cont...

- In case of a single stage compression refrigeration system operating between constant evaporator and condenser temperatures, the maximum possible COP is given by **Carnot COP**.
- The refrigeration system would be reversible if the heat from the source (Q_G) were transferred to a **Carnot heat engine**, and the work output of this heat engine ($W = \eta_{th,rev} \times Q_G$) is supplied to a **Carnot refrigerator** to remove heat from the refrigerated space.
- Note that $Q_L = W \times COP_{VCR,Rev} = \eta_{th,rev} \times Q_G \times COP_{VCR,Rev}$

$$COP_{VAR,Rev} = \frac{Q_L}{Q_G} = \eta_{th,rev} \times COP_{VCR,Rev} = \left(1 - \frac{T_o}{T_s}\right) \left(\frac{T_L}{T_o - T_L}\right)$$

5. Vapor Absorption Refrigeration Cycle

Cont...

Example

An ammonia-water ($\text{NH}_3\text{-H}_2\text{O}$) absorption refrigeration system operates under the following conditions:

- Evaporator temperature, $T_E = -10\text{ }^\circ\text{C}$
- Condenser temperature, $T_C = 40\text{ }^\circ\text{C}$
- Generator temperature, $T_G = 100\text{ }^\circ\text{C}$
- Refrigeration capacity, $Q_E = 10\text{ kW}$
- Pump work is negligible.

Determine the maximum:

- Heat supplied to the generator, Q_G
- Heat rejected in the absorber and condenser, $Q_A + Q_C$
- Coefficient of Performance (COP) of the system

5. Vapor Absorption Refrigeration Cycle

Cont...

Solution:

- Determine the COP of the Absorption System: $COP_{VAR} = \frac{Q_E}{Q_G}$
- Let's determine the Carnot COP of an absorption refrigerator:

$$COP_{VAR,Rev} = \left(1 - \frac{T_o}{T_s}\right) \left(\frac{T_L}{T_o - T_L}\right) \text{ OR, } COP_{VAR,Rev} = \left(1 - \frac{T_C}{T_G}\right) \left(\frac{T_E}{T_C - T_E}\right)$$

$$T_E = -10 \text{ }^\circ\text{C} + 273.15 = 263.15 \text{ K}$$

$$T_C = 40 \text{ }^\circ\text{C} + 273.15 = 313.15 \text{ K}$$

$$T_G = 100 \text{ }^\circ\text{C} + 273.15 = 373.15 \text{ K}$$

5. Vapor Absorption Refrigeration Cycle

Cont...

Substituting the values:

$$COP_{VAR,Rev} = \left(1 - \frac{313.15}{373.15}\right) \left(\frac{263.15}{313.15 - 263.15}\right) = 0.846$$

Note: This is the **maximum theoretical COP**. In practice, the actual COP will be lower due to irreversibilities.

- The heat supplied to the Generator (Q_G):

$$COP_{VAR} = \frac{Q_E}{Q_G}$$

$$Q_G = \frac{Q_E}{COP} = \frac{10 \text{ kW}}{0.846} = 11.82 \text{ kW}$$

5. Vapor Absorption Refrigeration Cycle

Cont...

- The total heat rejected in the Absorber and Condenser ($Q_A + Q_C$)
- From the energy balance for the entire system:

$$Q_G + Q_E = Q_A + Q_C$$

$$Q_A + Q_C = 11.82 \text{ kW} + 10 \text{ kW} = 21.82 \text{ kW}$$

Summary

- Ideal Vapor Compression Refrigeration Cycle operates with four main processes—compression, condensation, expansion, and evaporation—under idealized conditions without inefficiencies like friction or pressure drops.
- Energy analysis of Vapor Compression Refrigeration Cycle evaluates energy consumption and efficiency using performance parameters like the coefficient of performance (COP), which measures cooling effect relative to work input.
- Real Vapor Compression Refrigeration Cycle considers practical losses such as pressure drops, non-ideal compressor efficiency, and refrigerant property variations, leading to deviations from the ideal cycle.
- Vapor Absorption Refrigeration Cycle uses thermal energy (rather than mechanical work) to drive the refrigeration cycle, commonly employing a liquid absorbent and refrigerant pair, such as lithium bromide and water.

References

- [1]. Thermodynamics – An Engineering Approach, Cengel Y A.,Bole M A., McGraw-Hill Education, 8th edition 2015.
- [2]. Refrigeration and Air Conditioning Technology, William C. Whitman, William M. Johnson, John A. Tomczyk, Cengage Learning, 2022 (9th Edition).
- [3]. Principles of Refrigeration, Roy J. Dossat, Horace J. Horan, Pearson, 2002, (5th Edition)
- [4]. Absorption Cooling: Advances in Refrigeration and Heat Pump Technology, Kim Choon Ng, Bidyut Baran Saha, Anutosh Chakraborty, Springer, 2017.
- [5]. Absorption Chillers and Heat Pumps, Keith E. Herold, Reinhard Radermacher, Sanford A. Klein, CRC Press, 2016.

Thank you !