

# **Power Plant Engineering**

## **Lecture 7**

### **Steam Turbines**

**Lecturer: Dr. Melaku Desta**

# ***Lecture learning outcomes:***

At the end of this lecture, you will be able to:

- i. Explain the working principle and main components of an impulse turbine and how energy is converted from steam to mechanical work.
- ii. Differentiate between impulse and reaction turbines based on pressure and velocity changes through the nozzles and blades.
- iii. Construct and interpret the velocity diagram for an impulse turbine blade to determine blade speed and steam velocities.
- iv. Determine the blade efficiency of a steam turbine and analyze factors influencing turbine performance.
- v. Describe and evaluate the concept of axial thrust on a rotor and discuss methods used to minimize or balance it in turbine design.

# Content

1. Introduction
2. Impulse Turbine
3. Reaction Turbine
4. Velocity Diagram for Impulse Turbine Blade
5. Steam Turbine Blade-efficiency
6. Axial Thrust on Rotor

Summary

References

# 1. Introduction

- **Steam turbines** are vital components in modern power generation systems, where thermal energy from steam is efficiently converted into mechanical work.
- Among various types of turbines, **impulse** and **reaction** turbines are the two fundamental classifications based on how energy **conversion occurs** within the blades [1].
- The theory of **turbo machines** is based on the relationship between **jets** and **vanes**, where:
  - ✓ **Jets** – high velocity stream of fluid
  - ✓ **Vanes** – the mechanical element of the machine
- A **jet** is a stream of fluid (liquid or gas) that is projected into a surrounding medium, or against a surface, at a high velocity.

# 1. Introduction

Cont...

- A **vane** is a blade or a surface designed to guide, direct, or be pushed by a fluid flow.
- **Vane** is a term usually used in **fluid mechanics**, while **blade** is the term used in **power plant**, and therefore it is to be used further on.
- In a **steam turbine**, the steam flow passes through two main types of blades which work together to convert steam energy into mechanical work.
  - i. **Fixed Blades**
  - ii. **Moving Blades**

# 1. Introduction

Cont...

## i. Fixed Blades (Nozzles)

- These blades are **stationary** and attached to the turbine casing.
- Their main function is to convert the **pressure energy** of steam into **kinetic energy** by accelerating the steam jet (act as nozzles).
- They direct the **high-velocity steam** onto the moving blades at an appropriate angle for efficient energy transfer.

## ii. Moving Blades (Rotor Blades)

- These blades are mounted on the turbine rotor and **rotate** when struck by high-velocity steam.
- Their main role is to convert the kinetic energy of steam into **mechanical energy** (rotational motion).

# 1. Introduction

Cont...

- As far as **power plant** is concerned, moving blade system is of main interest, although **nozzles** are also used and may be considered as fixed element together with the moving blades.
- In the **moving blade** system, the following remarks are of special interest:
  - The fluid flows **tangentially** on the blade to prevent sudden impact force (shock).
  - Such tangential fluid entry means almost **negligible friction** with the blade surface.
  - Tangential velocity in a circular (curved) shapes means
    - ✓ tangent to the curved surface
    - ✓ perpendicular to the curved section.

# 1. Introduction

Cont...

## Principle of Turbine Operation

- **Turbines** operate on the principle of converting **fluid energy**—such as steam, gas, or water—into **mechanical energy** through rotational motion.
- This mechanical work is almost always used to **rotate a shaft**, which can then drive a **generator** to produce electricity, power a ship's propeller, or run a pump.
- The operation of turbines is based on **Newton's Third Law of Motion** and the conservation of energy [1]:
  - A high-energy fluid (steam, gas, or water) strikes the turbine blades.
  - The blades deflect the fluid, and the reaction force causes the rotor to spin.
  - This rotational motion is transferred to a shaft, which can drive generators or other machinery.

# 1. Introduction

Cont...

- Steam turbines can be classified according to several factors:

- a. According to the **Principle of Operation**

- 1. **Impulse Turbine**

- 2. **Reaction Turbine**

- b. According to the **Direction of Steam Flow**

- 1. **Axial Flow Turbine**

- Steam flows parallel to the axis of rotation.
    - Most modern turbines are of this type.

- 2. **Radial Flow Turbine**

- Steam flows perpendicular to the axis of rotation
    - Used mainly in small turbines or special-purpose applications.

# 1. Introduction

Cont...

## c. According to the **Number of Stages**

### 1. **Single-Stage Turbine**

- Expansion of steam occurs in **one set** of fixed and moving blades.
- Suitable for small power outputs.

### 2. **Multi-Stage Turbine**

- Steam expands through **multiple sets** (stages) of blades.
- Used in large power plants for better efficiency and smoother expansion.

# 1. Introduction

Cont...

d. According to the **Pressure of Steam**

1. **High-Pressure Turbine** - Steam inlet pressure above 40 bar.
2. **Medium-Pressure Turbine** - Steam inlet pressure between 10–40 bar.
3. **Low-Pressure Turbine** - Steam inlet pressure below 10 bar.

e. According to **Exhaust Conditions**

1. **Condensing Turbine**

- Steam exhausts into a condenser under vacuum.

2. **Non-Condensing (Back-Pressure) Turbine**

- Steam exhausts at atmospheric or higher pressure for use in industrial heating or processes.

# 1. Introduction

Cont...

f. According to the **Type of Governing**

## 1. Throttle Governing

- Controls steam pressure by throttling at the inlet.

## 2. Nozzle Governing

- Controls steam flow by opening or closing groups of nozzles.

## 3. Bypass Governing

- Bypasses steam to control load in multi-stage turbines

## 2. Impulse Turbine

- An **impulse turbine** converts the **kinetic energy** of a high-velocity fluid jet into **mechanical energy** by striking blades mounted on a rotor.
- Impulse turbines are a class of **hydraulic** or **steam turbines** where the fluid's pressure energy is first converted into kinetic energy before striking the turbine blades [2].
- They are widely used in **hydroelectric** power plants and steam power systems.
- Impulse turbines operate based on the principle of impulse, where **high-velocity jets of fluid** are directed onto the turbine blades. The force of the fluid jet causes the turbine blades to rotate.

**Example:** Pelton turbines and Turgo turbines

## 2. Impulse Turbine

Cont...

### ■ Principle of Operation of Impulse Turbines

- The impulse turbine works on **Newton's Second Law of Motion** — the rate of change of momentum of a fluid is equal to the force acting on it [2].
- The steam expands completely in the nozzle, converting pressure energy into kinetic energy.
- The **high-velocity jet of steam** impinges on the curved moving blades (or buckets).
- The change in momentum of the steam as it strikes and leaves the blades produces an **impulse force** on the blades.
- This impulse force rotates the turbine wheel, and the mechanical energy is transmitted to the generator through the shaft.

## 2. Impulse Turbine

Cont...

### Main Components of Impulse Turbines

- An impulse turbine mainly consists of the following parts:
  1. **Nozzles** – Convert steam pressure energy into kinetic energy; direct steam jets onto moving blades.
  2. **Blades or Buckets** – Mounted on the rotor; change the direction of the steam jet, thus producing an impulse.
  3. **Rotor (Wheel)** – The rotating part carrying blades; converts linear impulse into rotational motion.
  4. **Casing** – Encloses the turbine to prevent steam leakage and direct exhaust steam properly.
  5. **Shaft** – Connected to the rotor; transmits mechanical energy to the generator.

## 2. Impulse Turbine

Cont...

### ■ Main Components of Impulse Turbines

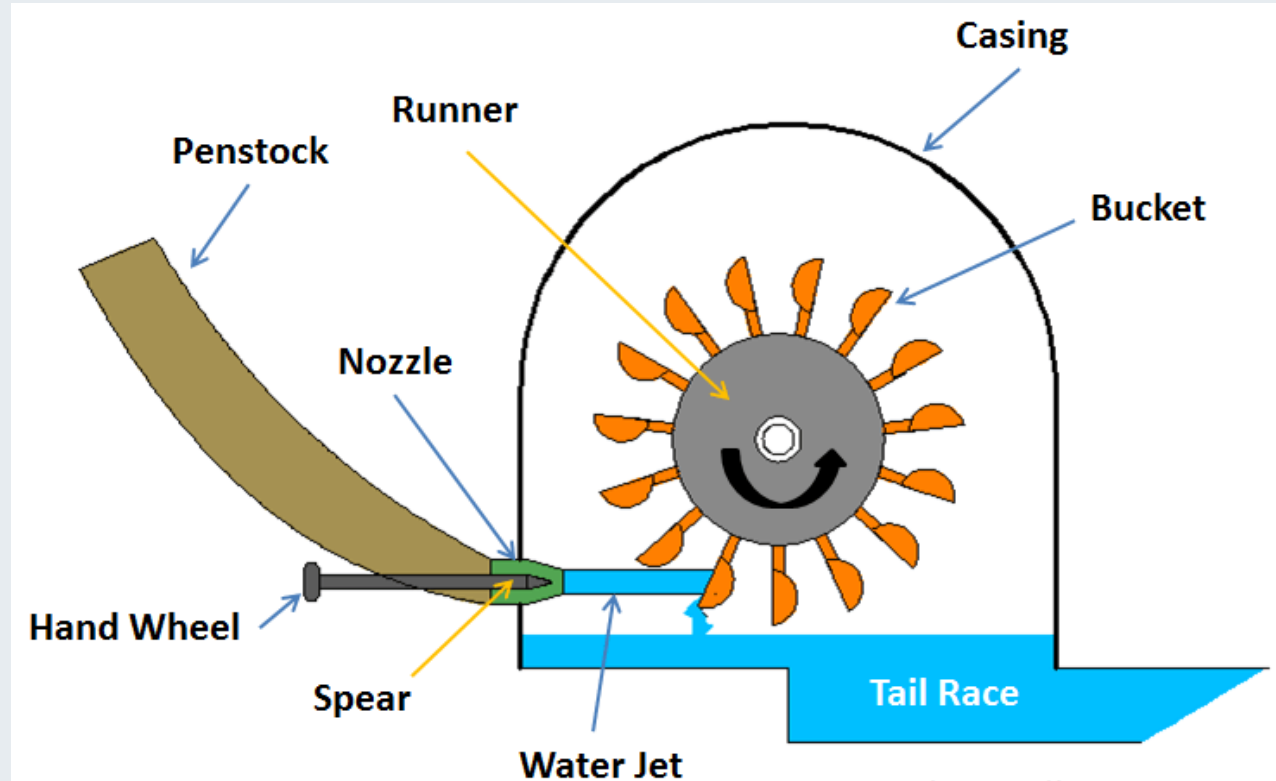

**Figure 1:** Main Components of Impulse Turbine, Mechanical Booster, (2018)

[url:https://mechanicalbooster.com/wp-content/uploads/2018/01/Impulse-Turbine-1.png](https://mechanicalbooster.com/wp-content/uploads/2018/01/Impulse-Turbine-1.png)

## 2. Impulse Turbine

Cont...

### The Pelton Wheel

- The Pelton Wheel is the quintessential example of an impulse turbine, used in **high-head** hydroelectric power plants.
- It converts the kinetic energy of a high-velocity water jet into mechanical energy.
- Invented by Lester **Allan Pelton in 1870s**, it is especially suited for **high head** and **low discharge** sites.
- It is one of the most efficient types of water turbines, with efficiencies up to 90% [3].

## 2. Impulse Turbine

Cont...

### The Pelton Wheel

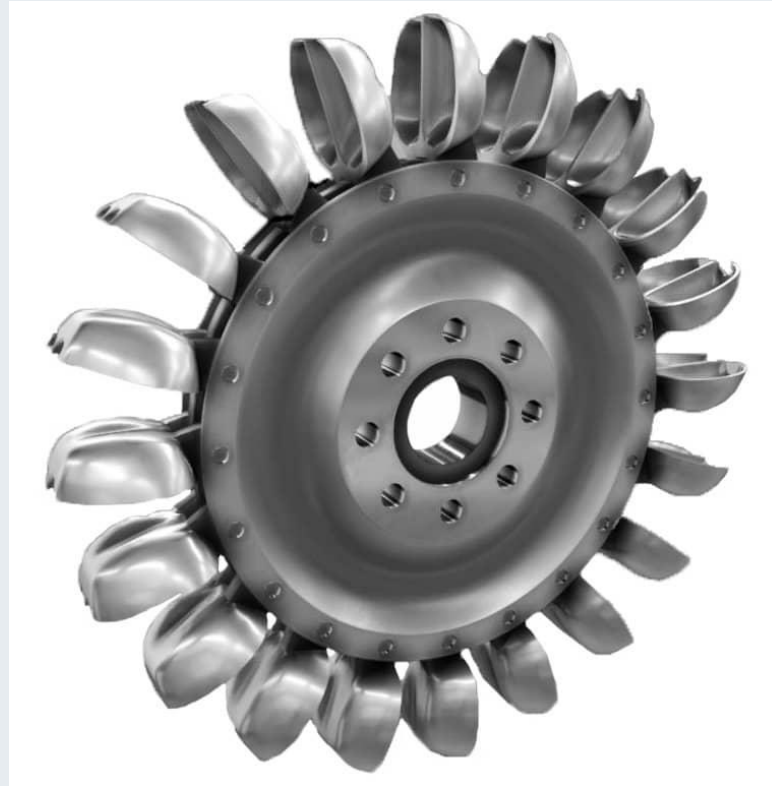

**Figure 2:** A Pelton Turbine (Pelton Wheel), Newfoundland and Labrador Hydro. (2025)

[url:https://savree-storage.s3.amazonaws.com/Articles/optimised/Pelton-Turbine-2-2.jpg](https://savree-storage.s3.amazonaws.com/Articles/optimised/Pelton-Turbine-2-2.jpg)

## 2. Impulse Turbine

Cont...

### Compounding of Impulse Turbine

- In a simple impulse turbine, steam expands completely in one or more nozzles to a very high velocity and then strikes the moving blades attached to a single wheel.
- However, this high-velocity steam causes:
  - ✓ Very high rotational speed of the rotor,
  - ✓ Mechanical stresses,
  - ✓ Frictional losses, and
  - ✓ Difficulty in directly coupling to generators
- To overcome these limitations, **compounding** is introduced.

## 2. Impulse Turbine

Cont...

- **Compounding** in an impulse turbine means **dividing the total pressure drop or velocity** of steam **into several stages**, so that the rotational speed of the turbine is reduced to a practical level without sacrificing efficiency [4].
- Each stage converts a part of the available energy, allowing the turbine to operate at lower speeds while still extracting the same **total energy** from the steam so that:
  - ✓ The turbine runs at a manageable speed
  - ✓ Efficiency improves
  - ✓ Energy extraction is more uniform

## 2. Impulse Turbine

Cont...

- There are **three** main types of compounding used in impulse turbines:
  1. Velocity Compounding (Curtis Turbine)
    - Used to reduce the rotor's **high speed** by splitting the total pressure drop and using multiple stages of moving blades.
  2. Pressure Compounding (Rateau Turbine)
    - a method used in steam turbines to split the total pressure drop across multiple stages of stationary nozzles and moving blades.
  3. Pressure-Velocity Compounding (Combination or Zoelly Turbine)

# 2. Impulse Turbine

Cont...

## 1. Velocity Compounding (Curtis Turbine)

- The compounding is done for **velocity of steam only** i.e. drop in velocity is arranged in **many small drops** through many moving rows of blades instead of a single row of moving blades.
- It consists of a nozzle or a set of nozzles and rows of moving blades attached to the rotor or wheel and rows of fixed blades attached to.
- The fixed blades are guide blades which guide the steam to succeeding rows of moving blades, suitably arranged between the moving blades and set in a reversed manner.
- Three rows or rings of moving blades are fixed on a single wheel or rotor and this type of wheel is termed as the three row wheel.

## 2. Impulse Turbine

Cont...

- The whole expansion of steam from the steam chest pressure to the exhaust pressure takes place in the **nozzles** only.
- There is **no drop** in either in the moving blades or the fixed i.e. the **pressure remains constant** in the blades as in the simple impulse turbine.
- The steam velocity from the exit of the nozzle is very high as in the simple impulse turbine.
- Steam with this high velocity enters the first row of moving blades and on passing through these blades, the velocity slightly reduces .
- It then enters the first row of guide blades which directs the steam to the second row of moving blades.

# 2. Impulse Turbine

Cont...

## 2. Pressure Compounding (Rateau Turbine)

- The compounding is done for **pressure of steam** only i.e. to reduce the high rotational speed of turbine.
- The whole expansion of steam is arranged in a number of steps by employing a number of simple turbine in a series keyed on the same shaft.
- Each of these simple impulse turbine consisting of one set of **nozzles** and **one row of moving blades** is known as a stage of the turbine and thus this turbine consists of several stages.
- The exhaust from each row of moving blades enters the succeeding set of nozzles.

## 2. Impulse Turbine

Cont...

- Thus we can say that this arrangement is nothing but **splitting up the whole pressure drop**.
- From the steam chest pressure to the condenser pressure into a series of smaller pressure drop across several stages of impulse turbine and hence this turbine is called, **pressure-compound** impulse turbine.
- In general, in pressure compounding,
- **Pressure:** Drops in steps, only across the **nozzles**. It remains constant across the moving blades.
- **Velocity:** Peaks at the exit of each **nozzle** and then drops as it passes through the **moving blades**.

# 2. Impulse Turbine

Cont...

## Velocity Compounding and Pressure Compounding

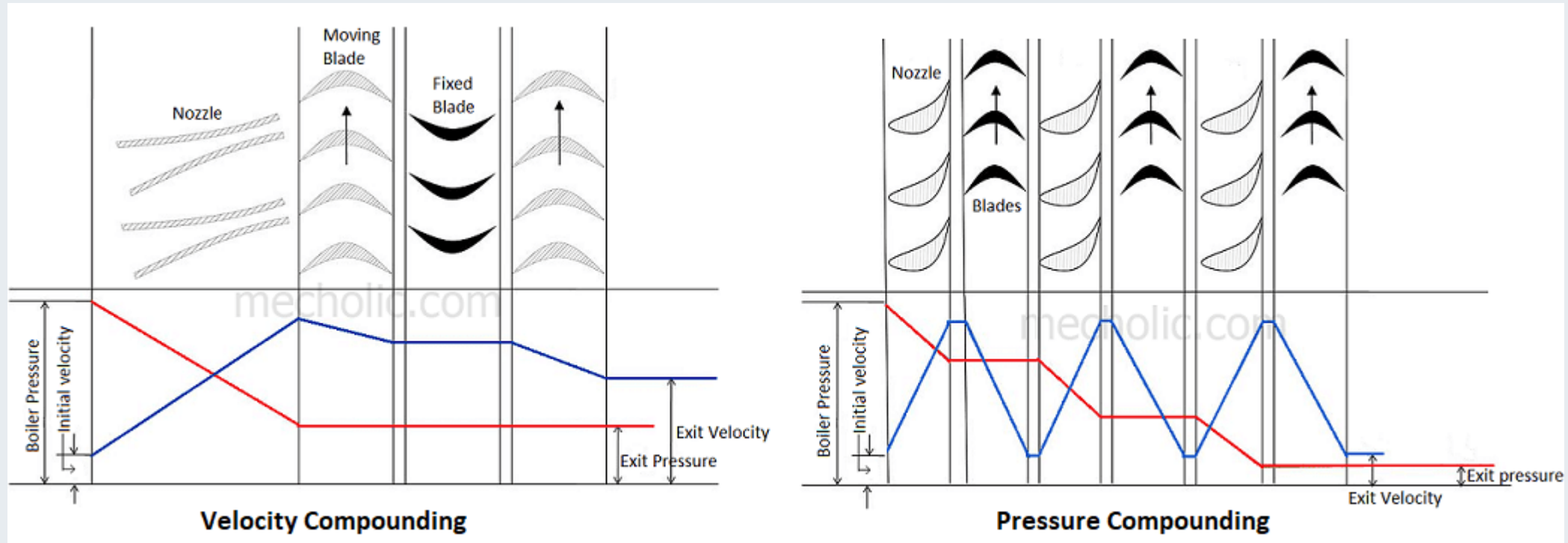

**Figure 3:** Difference between velocity compounding turbine and pressure compounding turbine, Mecholic. (2018).

[url:https://encrypted-tbn3.gstatic.com/images?q=tbn:ANd9GcT9wqdKgt7NNH3H7sTqu-WflaH9\\_0z5seEEIsLTBZ8\\_Ou6V3CaB](https://encrypted-tbn3.gstatic.com/images?q=tbn:ANd9GcT9wqdKgt7NNH3H7sTqu-WflaH9_0z5seEEIsLTBZ8_Ou6V3CaB)

## 2. Impulse Turbine

Cont...

### 3. Pressure-Velocity Compounding (Combination or Zoelly Turbine)

- This type of turbine is a combination of **pressure** and **velocity** compounding.
- There are **two wheels or rotors** and on each, only two rows of moving blades are attached cause two-row wheel are more efficient than three-row wheel.
- In each wheel or rotor, velocity drops i.e. drop in velocity is achieved by many rows of moving blades hence it is **velocity compounded**.
- There are two sets of nozzles in which whole pressure drop takes place i.e. whole pressure drop has been divided in small drops, hence it is **pressure-compounded**.

## 2. Impulse Turbine

Cont...

- In the first set of **nozzles**, there is some **decrease in pressure** which gives some kinetic energy to the steam and there is **no drop in pressure** in the two rows of **moving blades** of the first wheel and in the first row of fixed blades.
- There is a **velocity drop** in **moving blades** though there is also a slight drop in velocity due to **friction** in the fixed blades.
- In second set of nozzles, the remaining pressure drop takes place but the velocity here increases and the drop in velocity takes place in the moving blades of the second wheel or rotor.
- Compared to the pressure-compounded impulse turbine this arrangement was more popular due to its simple construction.
- It is, however, very rarely used now due to its **low efficiency**.

# 2. Impulse Turbine

Cont...

## Pressure-Velocity Compounding

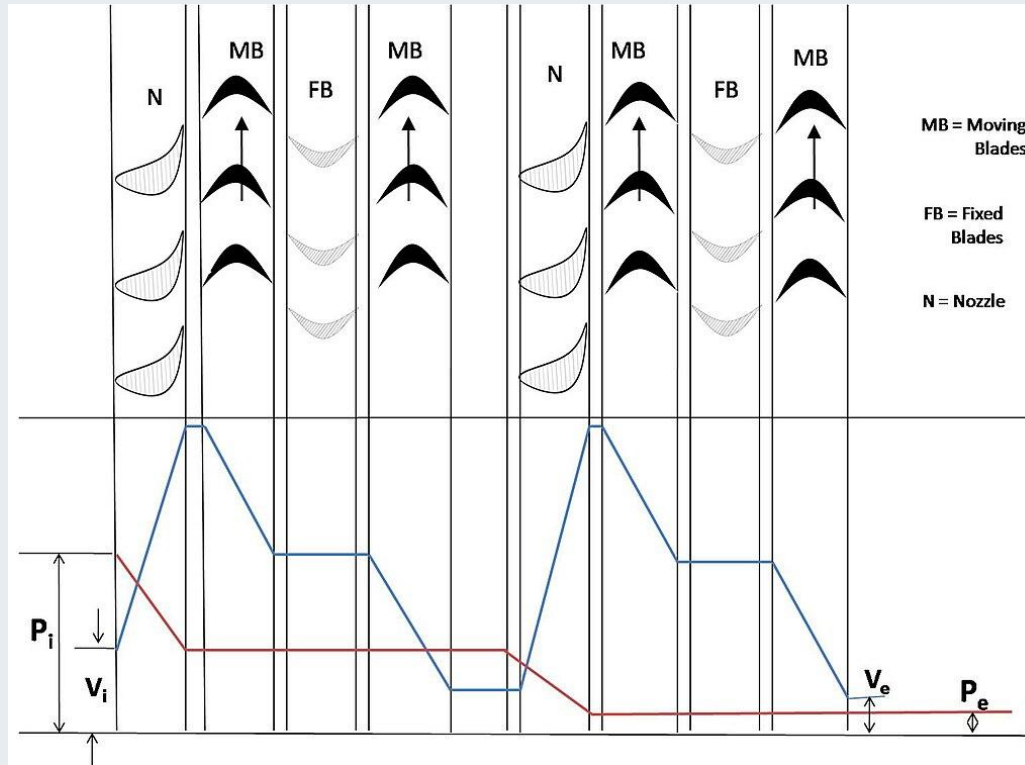

**Figure 4:** Pressure-Velocity Compounding of a Turbine, Kumar, Subikkumar, (2012).

[url: https://upload.wikimedia.org/wikipedia/commons/thumb/7/77/Fig5-Subik\\_Kumar-Schematic\\_Diagram\\_of\\_Pressure-Velocity\\_compounded\\_Impulse\\_Turbine.jpg/1024px-Fig5-Subik\\_Kumar-Schematic\\_Diagram\\_of\\_Pressure-Velocity\\_compounded\\_Impulse\\_Turbine.jpg](https://upload.wikimedia.org/wikipedia/commons/thumb/7/77/Fig5-Subik_Kumar-Schematic_Diagram_of_Pressure-Velocity_compounded_Impulse_Turbine.jpg/1024px-Fig5-Subik_Kumar-Schematic_Diagram_of_Pressure-Velocity_compounded_Impulse_Turbine.jpg)

# 3. Reaction Turbine

- A **reaction turbine** is a type of steam turbine in which steam expands continuously as it flows through both fixed and moving blades, causing a reaction force that produces rotation [5].
- Reaction turbines operate based on the principle of **reaction**, where the fluid flows through the turbine blades, and **both pressure** and **velocity energy** are converted into **rotational energy**.

**Examples:** Francis turbines, Kaplan turbines, and Propeller turbines are common types of reaction turbines used in hydroelectric power plants.

# 3. Reaction Turbine

Cont...

- Unlike the impulse turbine, where **expansion occurs only in nozzles**, in a reaction turbine:
  - Expansion of steam occurs partly in the **fixed blades** (nozzles) and
  - Partly in the **moving blades**, resulting in both **impulse** and **reaction** forces acting on the rotor.
- An impulse-reaction turbine combines features of both impulse and **reaction turbines** within a single stage.
- The turbine rotor **alternates** between sections that operate on the impulse and reaction principles.

# 3. Reaction Turbine

Cont...

## Reaction Turbine

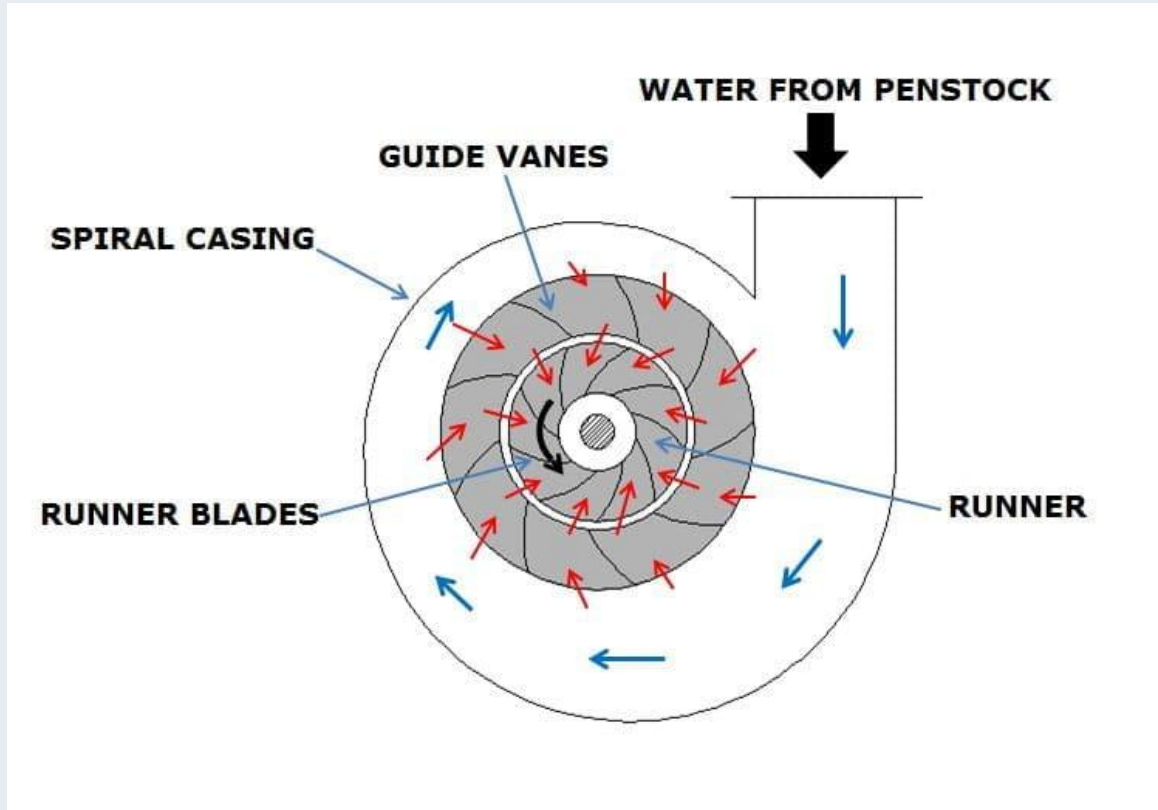

**Figure 5:** Reaction Turbine, The Mechanical Engineering, (2022)

[url:https://themechanicalengineering.com/wp-content/uploads/2022/02/FEATURE-IMAGE-OF-REACTION-TURBINE.jpg](https://themechanicalengineering.com/wp-content/uploads/2022/02/FEATURE-IMAGE-OF-REACTION-TURBINE.jpg)

# 3. Reaction Turbine

Cont...

- As steam expands while flowing over the moving blades:
  - It accelerates, producing a change in momentum.
  - The reaction force due to this change in momentum acts in the **opposite direction**, causing the rotor to turn.
- Thus, the rotation of the turbine rotor is due to:
  - **Impulse force** (from steam striking the blades), and
  - **Reaction force** (from steam expansion within the blades).

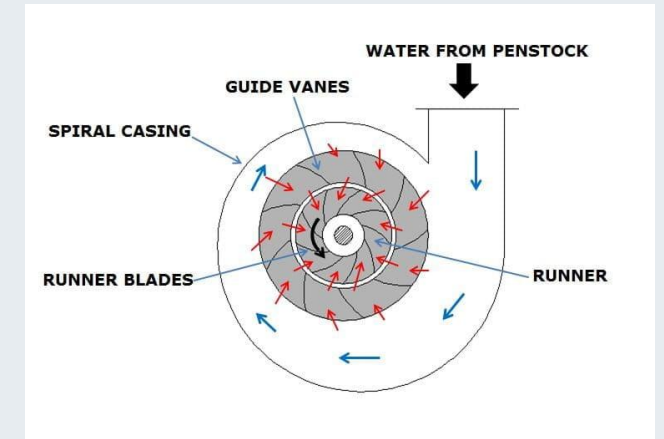

# 3. Reaction Turbine

Cont...

- A reaction turbine consists of the following main parts:

## 1. Fixed Blades (Nozzles)

- Attached to the stationary casing.
- Act as nozzles, converting part of the pressure energy into kinetic energy.
- Direct the steam onto the moving blades at a suitable angle.

## 2. Moving Blades

- Attached to the rotor.
- Steam expands further within these blades, producing reaction force and doing work on the rotor.

# 3. Reaction Turbine

Cont...

## 3. Rotor

- A shaft carrying the moving blades.
- Converts the kinetic and reaction energy of steam into rotational energy.

## 4. Casing

- Encloses the turbine to contain the steam and guide it properly from stage to stage.

## 5. Glands and Bearings

- Prevent steam leakage and support the rotor in smooth rotation.

# 4. Velocity Diagram for Impulse Turbine Blade

- In an impulse turbine, steam expands in **nozzles** only, converting its pressure energy into **kinetic energy**.
- The **high-velocity** jet of steam then impinges on the moving blades, changing direction and producing an **impulse force** that rotates the turbine wheel.
- To understand how this force produces work and efficiency, it is necessary to analyze the **velocity of steam** and blades using a **velocity diagram**.
- The velocity diagram helps in understanding the relationship between different velocities and in determining the **efficiency of the turbine**.

# 4. Velocity Diagram for Impulse Turbine Blade

Cont...

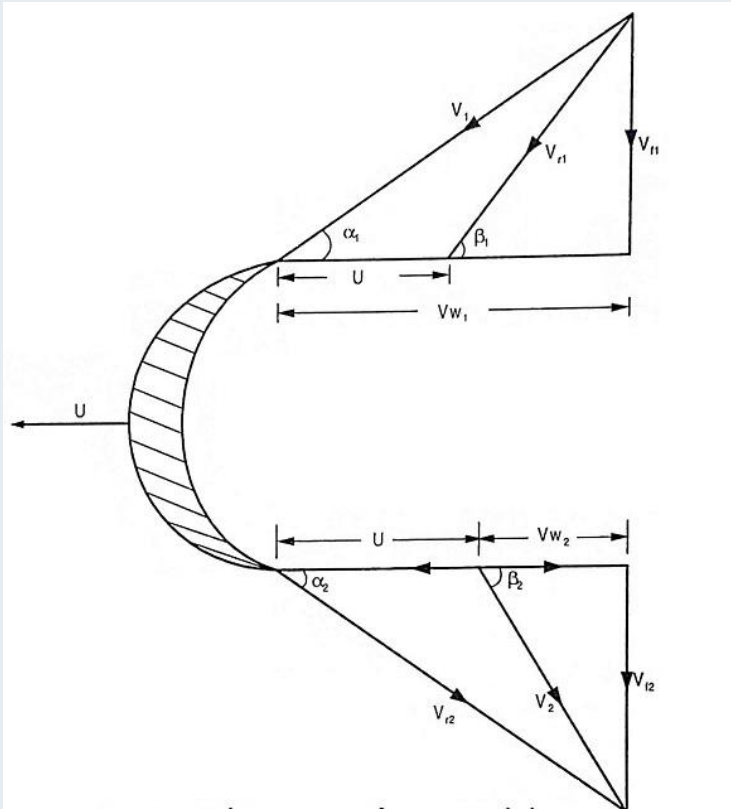

**Figure 6:** Velocity Diagram for Moving Blade, EEE Guide, (2022)  
[url:https://www.eeeguide.com/wp-content/uploads/2022/12/Steam-Turbine-Working-Principle-01.jpg](https://www.eeeguide.com/wp-content/uploads/2022/12/Steam-Turbine-Working-Principle-01.jpg)

Where

- $V_1$  and  $V_2$  = Absolute velocity of steam at entry and exit respectively
- $V_{w1}$  and  $V_{w2}$  = Velocity of whirl at the entry and exit respectively = Radial component of  $V_1$  and  $V_2$  respectively
- $V_{f1}$  = Velocity of flow at entry of moving blade = axial component of  $V_1$
- $V_{f2}$  = Velocity of flow at exit and moving blade = Axial component of  $V_2$
- $U$  = Blade velocity

# 4. Velocity Diagram for Impulse Turbine Blade

Cont...

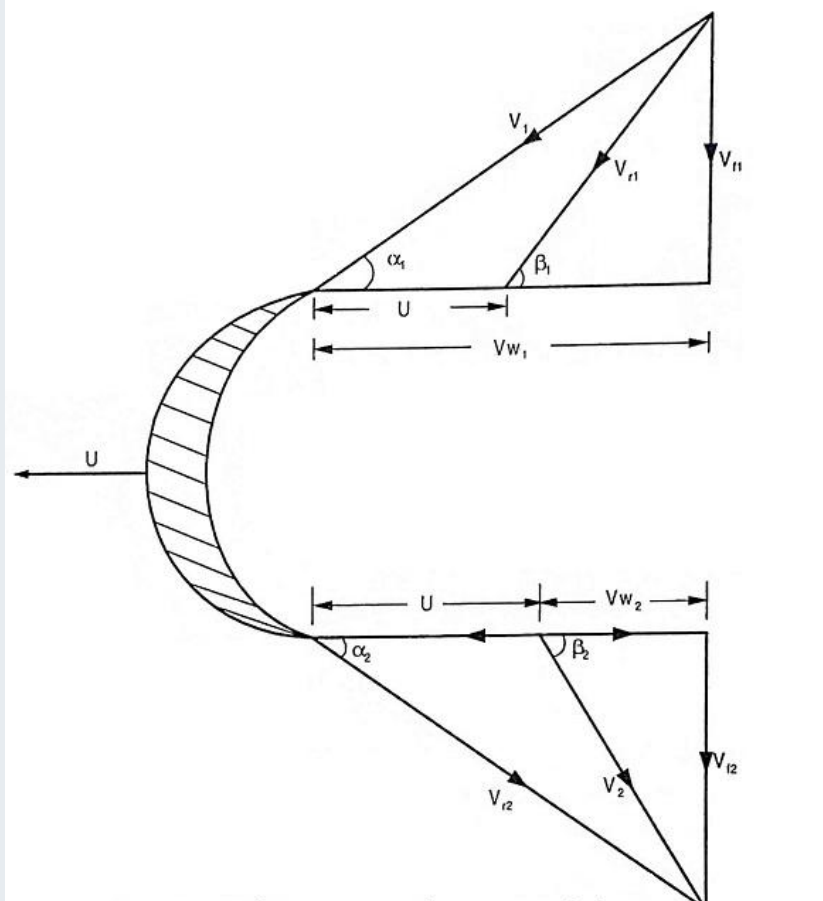

Where

- $V_{r1}$  and  $V_{r2}$  = Relative velocity at entry and exit

$$V_{r1} = V_1 - U$$

- $\alpha_1$  = angle with the tangent of the wheel at which the steam enters, also called nozzle angle.
- $\alpha_2$  = angle which the discharging steam makes with the tangent of the wheel at the exit.
- $\beta_1$  = Entrance angle of moving blade
- $\beta_2$  = Exit angle of moving blade

# 4. Velocity Diagram for Impulse Turbine Blade

Cont...

- In order to have simplicity while solving problem, it is a common practice to **combine the two vector velocity diagrams** on a common base.
- The diagram has been obtained by superimposing the **inlet velocity diagram** on the **outlet diagram** in order to coincide the blade velocity  $U$ .

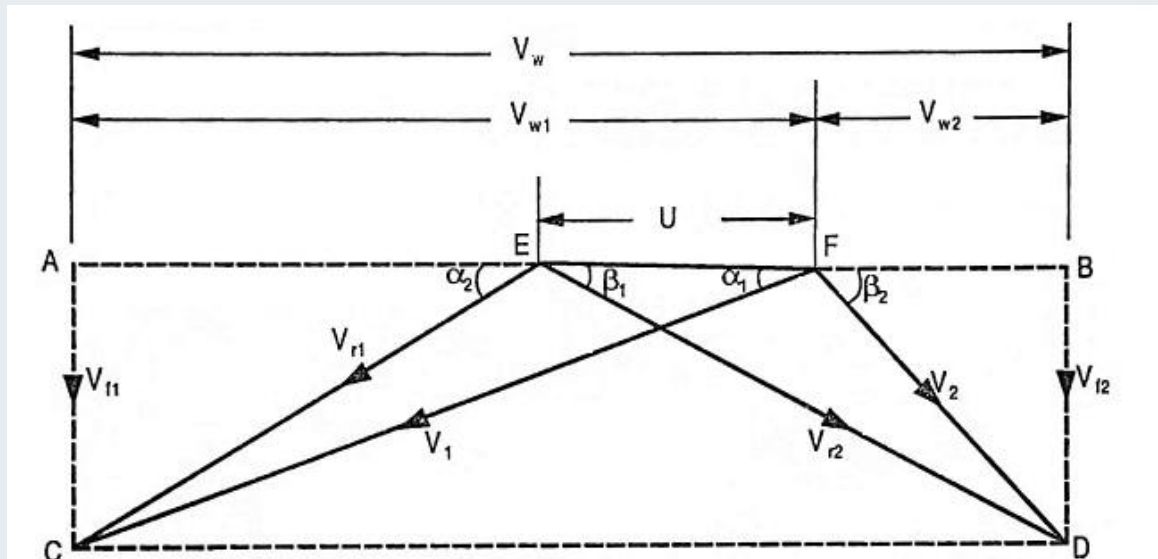

**Figure 7:** Velocity Diagram for Impulse Turbine, EEE Guide, (2022)

[url:https://www.eeeguide.com/wp-content/uploads/2022/12/Steam-Turbine-Working-Principle-02.jpg](https://www.eeeguide.com/wp-content/uploads/2022/12/Steam-Turbine-Working-Principle-02.jpg)

# 4. Velocity Diagram for Impulse Turbine Blade

Cont...

## Work done on the Blade

- The **work done** on the blade may be found out from the **change of momentum** of the steam jet during its flow over the blade.

- It is only the **velocity of whirl** which performs work on the blade since it acts in its (blade) direction of motion. Force on the wheel = Mass of steam x Acceleration

$$= \dot{m}(V_{w1} - V_{w2})$$

- $V_{w2}$  is actually **negative** as the steam is discharged in the opposite direction to blade motion, therefore consideration should be given to the fact that the values of  $V_{w1}$  and  $V_{w2}$  are to be added while solving the problems:

# 4. Velocity Diagram for Impulse Turbine Blade

Cont...

## Work done on the Blade/Sec

Work done on the blade/ sec = *Force x distance travelled/sec*

$$W = \dot{m}(V_{w1} + V_{w2}) \times U$$

$$W = \dot{m}V_w U , \quad (V_w = V_{w1} + V_{w2})$$

$$W = \frac{\dot{m}V_w U}{1000} \text{ kW}$$

Where:

$W$  = Work done per unit mass (J/kg)

$U$  = Blade speed (m/s)

$V_{w1}$  = Whirl component of absolute inlet velocity

(velocity tangent to the wheel) (m/s)

$V_{w2}$  = Whirl component of absolute outlet

velocity (m/s)

# 5. Steam Turbine Blade-efficiency

- **Steam turbines** are prime movers that convert the thermal energy of steam into mechanical energy by means of blades mounted on a rotor [6].
- The efficiency of these blades—called **blade efficiency** or **diagram efficiency**—plays a critical role in determining the overall performance of the turbine.
- **Blade efficiency** ( $\eta_b$ ) is defined as:

The ratio of the work done on the blades to the energy supplied to the blades by the steam jet.

$$\eta_b = \frac{\text{Work done on blades per kg of steam}}{\text{kinetic energy supplied by steam per kg}} = \frac{\text{Work done by blades}}{\frac{V_1^2}{2}}$$

Where  $V_1$  is the absolute velocity of steam entering the moving blade.

# 5. Steam Turbine Blade-efficiency

Cont...

## Stage Efficiency ( $\eta_{stage}$ )

- This is a broader term that includes **losses** not accounted for in the blade efficiency, such as:
  - Nozzle losses
  - Disc friction (windage) losses
  - Leakage losses (steam bypassing the blades)
  - Blade losses

$$\eta_{stage} = \frac{\text{Actual Work Output of the Stage}}{\text{Isentropic Enthalpy Drop across the Entire Stage}}$$

- It's crucial to note:  $\eta_{blade} > \eta_{stage}$

# 5. Steam Turbine Blade-efficiency

Cont...

## Factors Affecting Blade Efficiency

1. **Blade speed ( $u$ )** – must be optimized for maximum energy transfer.
2. **Inlet steam velocity ( $V_1$ )** – higher velocity increases available energy.
3. **Blade angle ( $\alpha_1, \beta_1, \beta_2$ )** – affects flow direction and losses.
4. **Blade friction ( $k$ )** – decreases relative velocity and efficiency.
5. **Blade surface condition** – rough surfaces cause turbulence and energy loss.

# 6. Axial Thrust on Rotor

- In steam turbines, steam expands and passes through **stationary** and **moving blades**, exerting forces on them.
- While most of these forces act **tangentially** (producing torque and useful work), there is also a **longitudinal** component of force acting along the axis of the turbine shaft.
- This longitudinal or axial force is known as **axial thrust** (or end thrust).
- Axial thrust is an **unavoidable** consequence of the pressure distribution and fluid momentum changes within a turbomachine.
- If not properly balanced, axial thrust can cause **mechanical stress** on the rotor and bearings, leading to wear, vibration, and performance issues.

# 6. Axial Thrust on Rotor

Cont...

- Consider the velocity diagram of a turbine blade:

- The **axial thrust** ( $T_a$ ) on the blades is:

$$T_a = \dot{m}(V_{f1} - V_{f2})$$

- Where

- $V_{f1}$  = Axial (flow) velocity of steam at blade inlet

- $V_{f2}$  = Axial (flow) velocity of steam at blade outlet

- $\dot{m}$  = Mass flow rate of steam (kg/s)

- If  $V_{f1} > V_{f2}$ , the thrust acts **in the direction** of steam flow.

- If  $V_{f2} > V_{f1}$ , the thrust acts **opposite** to the direction of flow.

# Summary

- In an impulse turbine, steam expands completely in nozzles, producing high-velocity jets that strike the blades, causing rotation by change of momentum only.
- In reaction turbines, steam expands both in fixed and moving blades, producing torque through combined impulse and reactive forces.
- Velocity diagram for impulse turbine blade illustrates relationships among absolute, relative, and blade velocities, used to determine blade work and efficiency.
- The blade efficiency of steam turbine depends on velocity ratio, blade angles, and friction; maximum efficiency occurs when blade speed is about half the jet speed.
- Axial thrust on rotor is the net force along the turbine axis due to change in steam velocity; must be balanced or minimized to protect bearings and maintain alignment.

# References

- [1]. Power Plant Engineering, R.K. Rajput, 3rd Edition, 2011.
- [2]. Pelton and Crossflow Impulse Hydraulic Turbines — Zulcy de Souza, Geraldo Lúcio Tiago Filho. Springer Cham, 2025.
- [3]. Pelton and Crossflow Impulse Hydraulic Turbines — de Souza, Zulcy & Tiago Filho, Geraldo Lúcio. Springer Cham, 2025.
- [4]. Turbines, Compressors and Fans (4th ed.), Yahya S.M, Tata McGraw Hill Education Private Limited, 2011.
- [5]. Influence of Partial Admission on the Downstream Stages of a Reaction Turbine: An Analytical Approach Verified by Measurements — W. Beer. ASME, 2013.
- [6]. Essentials of Steam Turbine Design and Analysis, Kumana, J. D, AIChE CEP, 2018.

Thank you !