

2- .C . ,

: ,

, ,

,

.

:

1. C .

2. - .

3. .

4. .

:

1. . . . . , , 1984, 13...39

.

2. . . . . , , 1996, 15...57 .

1. C

: , ,

, , ,

, ,

.

,

.

, .

, . ,

:

- , ,

;

- , ;
- - ( , , ) ;
- , , ) ;
- , ;
- (1 ) ;
- (1-10 ) ;
- (10-200 ) ;
- (0,2-1,0 ) ;
- (1 . ) ;

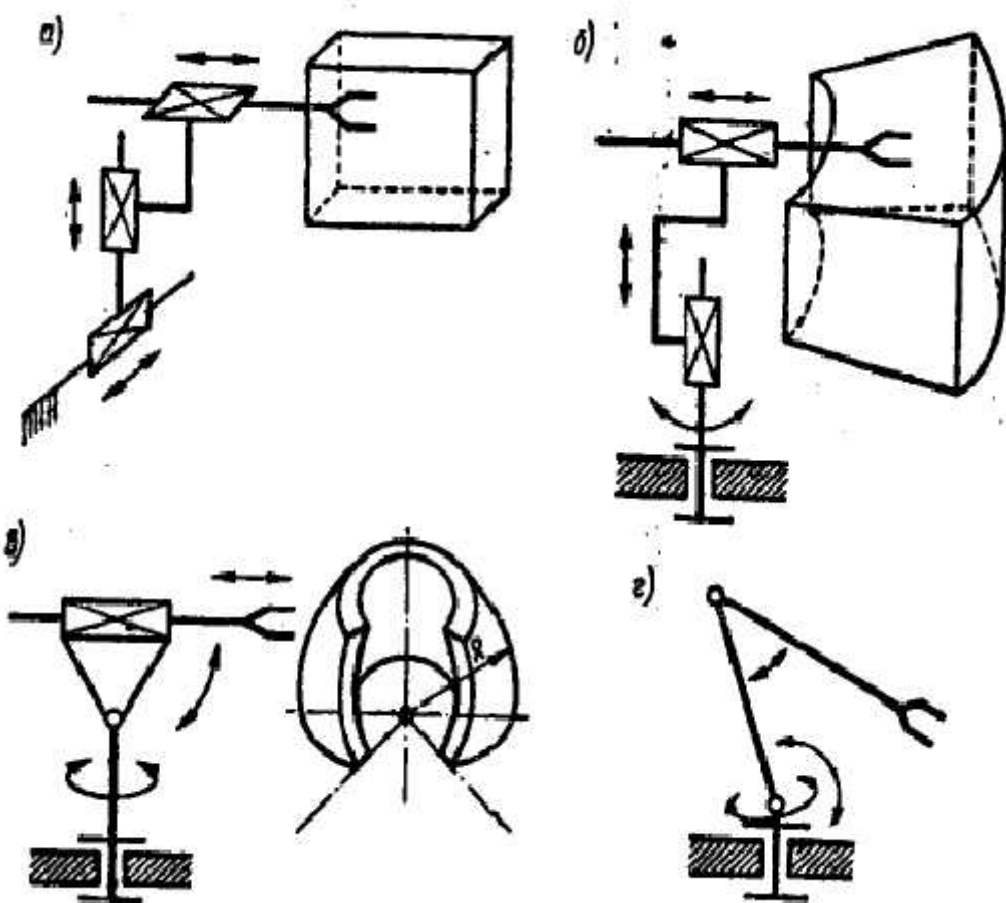

- ( ) (2.1-  
 , );  
 - (2.1- , );  
 - (2.1- , );  
 - (2.1-  
 , ).  
 C

2.

2.2-

( )

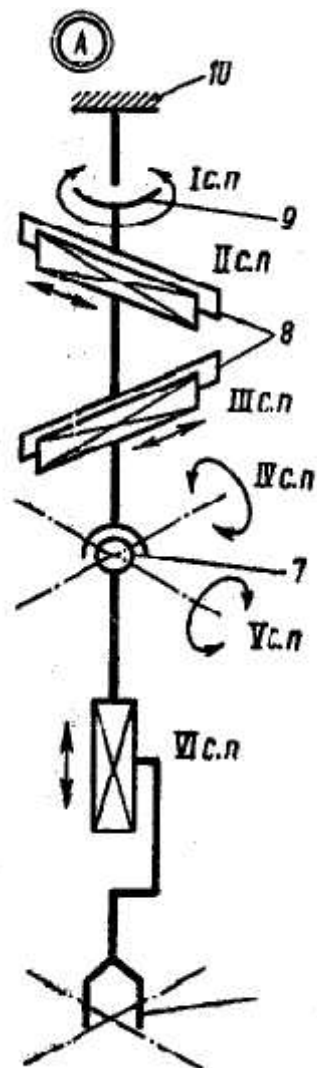
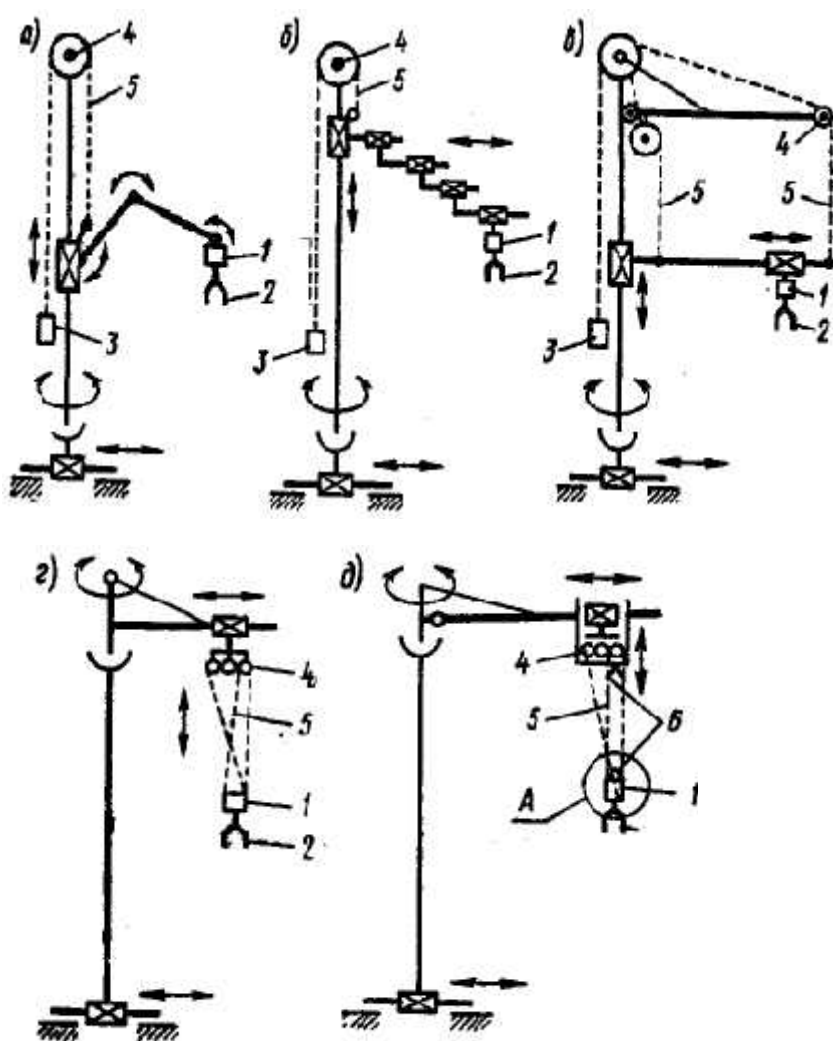

2.2-

2.2- , 1- , 2- , 3-  
, 4- , 5- , 6- , 7-  
, 8- - , 9-  
- , 10- .

**3.**

C

**4.**



1. C

?

2. C

?

3.

.

4.

?

5.

.

6.

?