

6- .

:

:

1. ().
3. .
4. .

1. . . . « » , « » , , 1990, 334...336 .
2. . . . « » , 1996, 69...77 .

1.

« »

»

3

6.1-

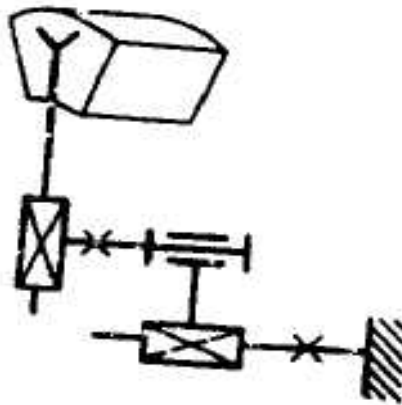

6.1- .

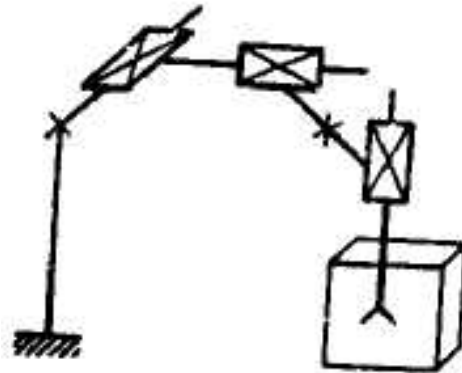

6.2-

6.2-

. C
2 -

(6.3-).

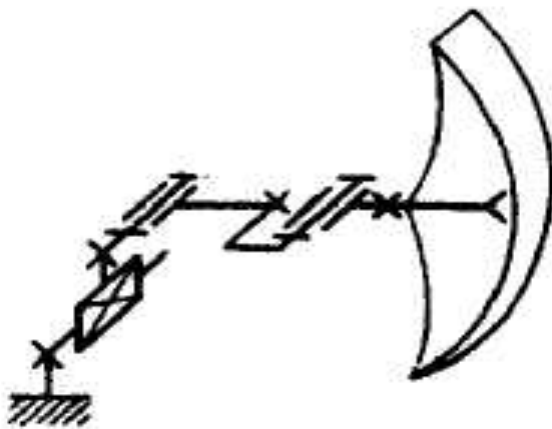

6.3-

C
:

ε ,

,

3 -

(6.4-).

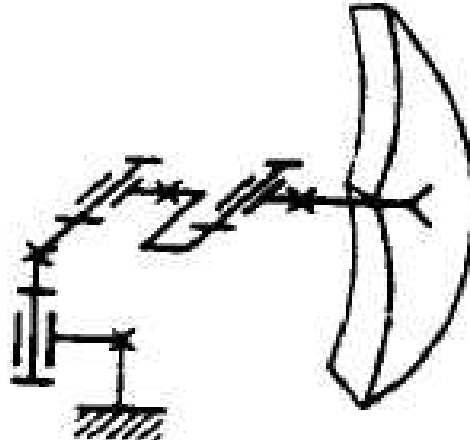

6.4- .

,

,

C

, «

»

.

,

(

)

(6.5-

).

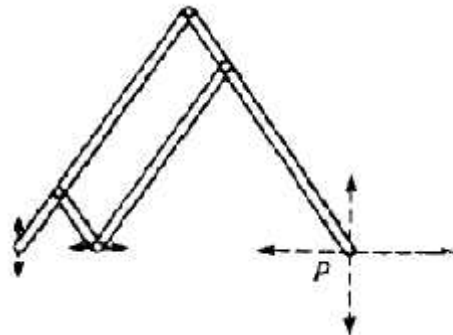

6.5- .

()
 (6.6-).

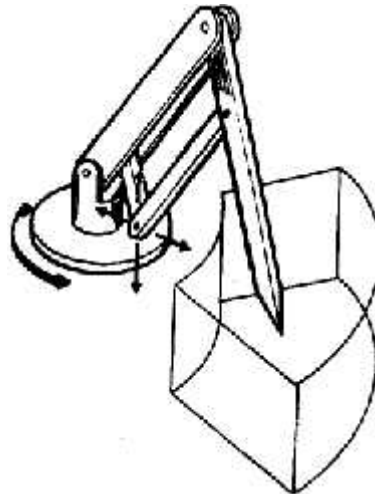

6.6- .
 (α, δ, φ)

C

3
 (θ, γ, β)

6.7-

6.8-

(θ_1, θ_2)

()

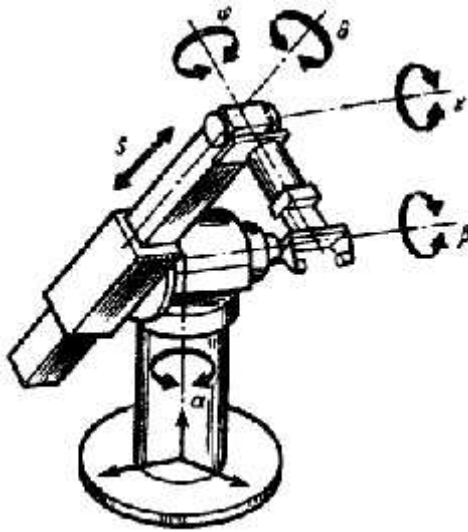

6.7- .

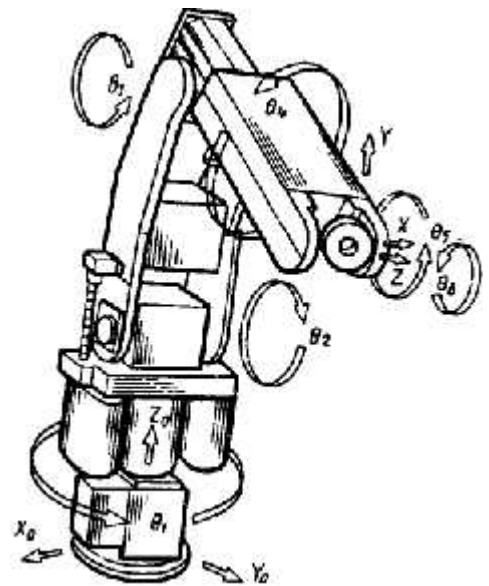

6.8- .

6.9-

()

()

()

()

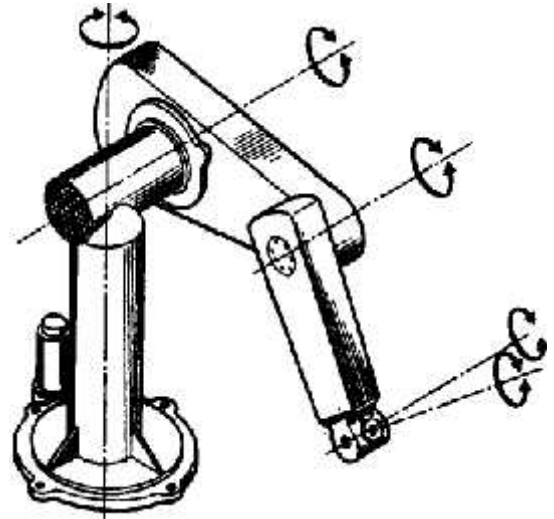
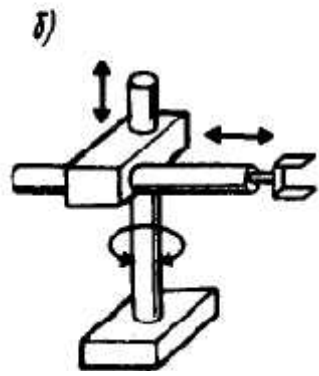
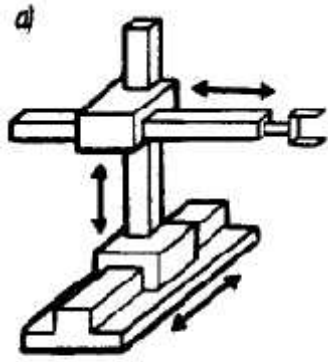

6.9-

3.

4.

1.

1.

2. θ, θ

3. C

?