

ADVANCED BIO MEDICAL INSTRUMENTATION

LECTURE 1: BIOMEDICAL SIGNALS

Biomedical signals are signals used to extract information of physiological activities of organisms, ranging from gene and protein sequences, to neural and cardiac rhythms, to tissue and organ images. Signals can be obtained by hand or using sensors and electrodes.

The various sources of biomedical signals are-

Bioelectric Signal – These are generated by nerve cells and muscle cells and main source is cell membrane potential. Examples- ECG, EEG, EMG.

Bioacoustic Signals – Signals obtained from sounds generated in the body. Eg- flow of blood in heart, flow of air through airways and lungs.

Biochemical Signals – Signals originated as a result of chemical measurements from living tissues. Eg- pCO₂, pO₂, etc

Bio optical signals- From optical functions of biological systems.

Bio impedance signals- Measures the impedance of the subject. Eg- Gives the galvanic skin resistance

1.2 BASIC MEDICAL INSTRUMENTATION SYSTEM

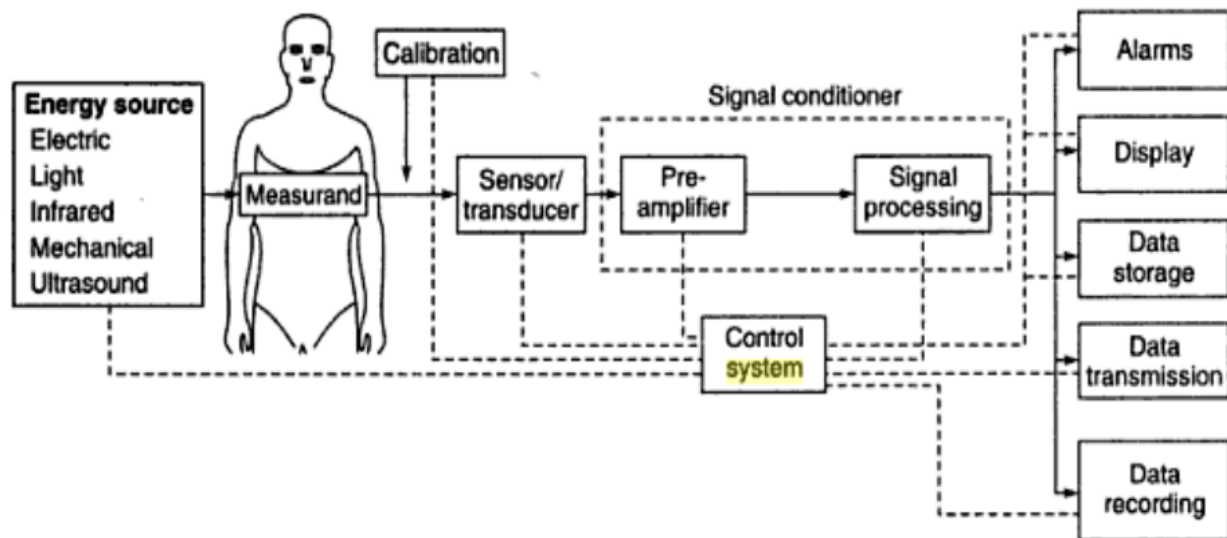

A medical system is used to determine the presence of a Biosignal. The four basic functional components are- Measurand (quantity to be measured), Transducer (converts one form of energy to another), Signal conditioner (converts output of transducer to an electrical quantity) and Display system (visible presentation of the output on a screen or scale or chart).

ADVANCED BIO MEDICAL INSTRUMENTATION

1.3 ORIGIN OF BIOELECTRIC SIGNALS

These signals are generated at cellular levels and the source is ionic in nature.

- Resting potential, Action potential, Depolarisation, repolarisation and polarization.

ECG - Electrocardiography is the process of recording the electrical activity of the heart over a period of time using electrodes placed on a patient's body.

EMG- Signals obtained from the muscles's action potential

EEG- Signals obtained from the electrical activity of the brain.

1.4 MEDICAL SURFACE ELECTRODES AND PROBLEMS

Electrodes are used to pick up electrical signals from the body.

Surface electrodes – Large surface area surface electrode are used for ECG and small surface area surface electrode are used for EMG and EEG.

1. Metal plate electrodes- rectangular or circular.
2. Suction cup electrodes – attachment to flat surfaces
3. Adhesive tape electrode/Disposable – Adhesive tape electrodes are used to prevent the squeezing out of electrode paste from normal surface electrodes.
4. Multipoint electrode – Has 1000 fine active points
5. Floating electrode – Contact with skin done via electrolytic bridge. Also called liquid junction electrode.
6. Limb electrodes- For ECG. Used during surgery.

Problems

- Interference if shielded cables are not used.
- Ohmic noise
- Movement artifacts
- Poor signal to noise ratio

1.5 MICROELECTRODES

A microelectrode is an extremely small electrode with a tip which is capable of being inserted into the wall of a single cell without causing damage. Also called intracellular electrodes. Tip dimensions are 0.5 to 5 microns.

Two types- metallic and nonmetallic (glass)-also called micropipette. Reference cell is always outside the cell.

Metallic electrodes are formed from a fine needle of a suitable metal drawn to a fine tip. Glass electrodes are drawn from pyrex glass. The microcapillaries are filled with electrolytes. These have very high impedance.

ADVANCED BIO MEDICAL INSTRUMENTATION

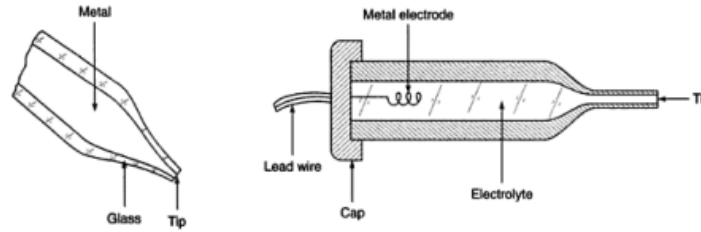

1.6 ELECTROCARDIOGRAPH

An ECG is an instrument used to measure and record the electrical activity of the heart. It provides information about a range of various cardiac disorders.

1.6.1 BLOCK DIAGRAM

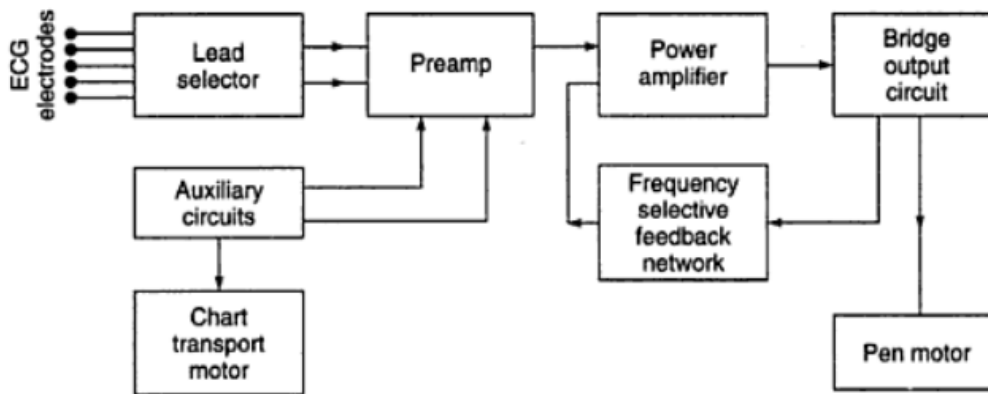

The potentials picked up by the electrodes are sent to a lead selector switch, which selects the leads which has been specified. The signals are sent to a differential preamplifier. (3 or 4 stage). The output is amplified and given to a push pull power amplifier. This output is given to a pen motor which deflects the stylus on the paper. RC network gives the necessary damping. Speed control of pen and a calibration circuit is provided in the auxillary circuits. An isolation amplifier gives electrical safety. The paper recording speed is 25mm/s. Sensitivity is 10mm/mV.

1.6.2 ECG LEADS

2 electrodes placed over different parts of the body picks the PD and give the signals. This PD changes in a regular and complex manner for each cardiac cycle. There are 3 types of electrode systems-

1. Bipolar or standard lead system – ECG recorded by 2 electrodes and trace is the potential difference between them.

The electrodes are placed on the wrists and ankles of the limbs. Both arms and the left leg are used as active leads (i.e. they became one of the poles in the recording), while the right leg is used as a ground.

ADVANCED BIO MEDICAL INSTRUMENTATION

Leads	Position	position
Lead 1	RA	LA
Lead 2	RA	LL
Lead 3	LA	LL

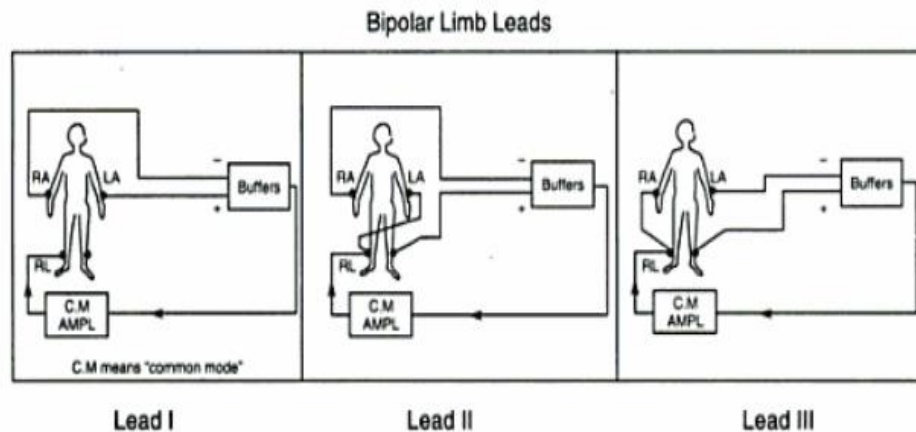

2. Augmented unipolar system – ECG is recorded between a single exploratory electrode and a central terminal which has a potential corresponding to the centre of the body. 2 equal and large resistors are connected to a pair of limb electrodes and the centre acts as central terminal and remaining electrode as the exploratory electrode. These are called the augmented unipolar leads. (aVR, aVL, aVF)

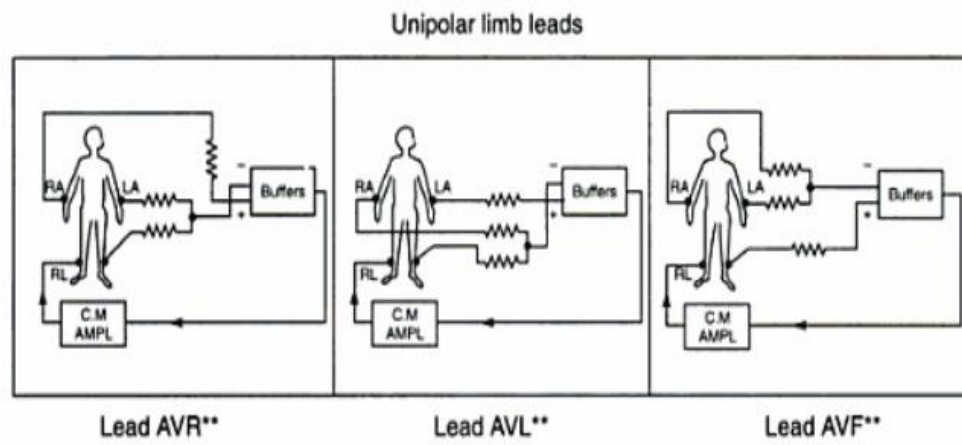

3. Chest or precordial lead system – It uses an exploratory electrode to record potential on the chest at 6 different positions. Designated as V. Also called Wilson system. 12 leads are present here- 3 bipolar leads, 3 unipolar leads and 6 chest leads.

ADVANCED BIO MEDICAL INSTRUMENTATION

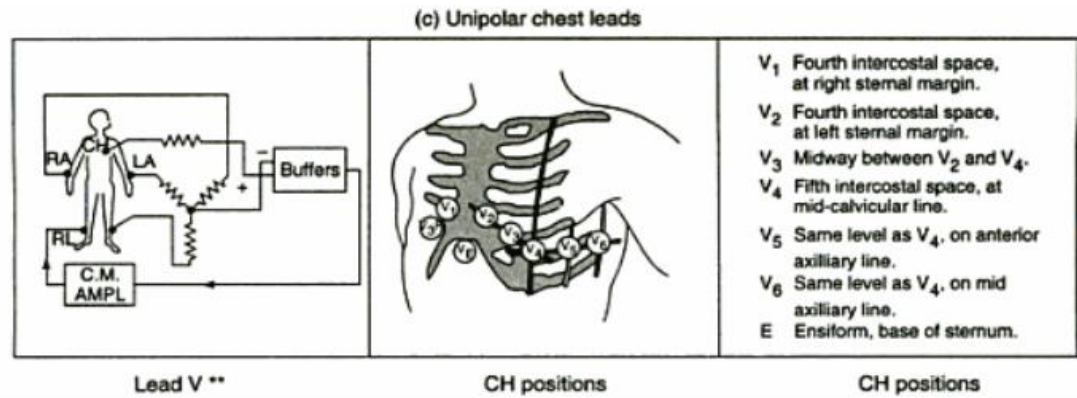

1.6.3 FAULTS AND TROUBLESHOOTING

1. Interference from the power line
2. Shifting of baseline
3. Muscle tremor
4. Solid baseline

1.7 PHONOCARDIOGRAPH

The instrument used to measure the heart sounds is a phonocardiograph. It uses a phono catheter with a microphone at the tip. These sounds give indication of heart rate and its rhythmicity. Also the effectiveness of blood pumping and valve action.

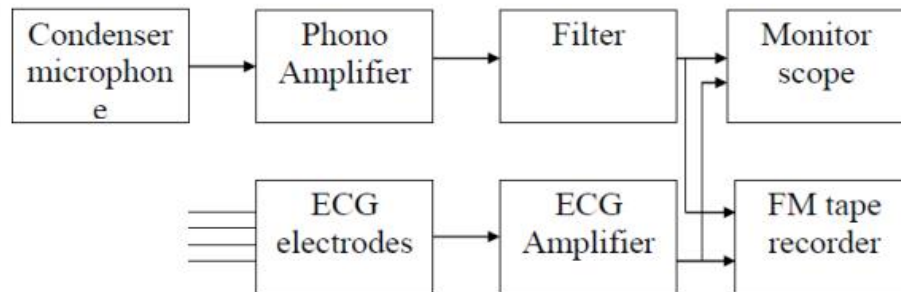

1.7.1 ORIGIN OF HEART SOUNDS

The sounds are produced by the mechanical events that occur during the heart cycle. These sounds are due to the sounds and murmurs produced by the contracting heart, including its valves and associated great vessels.

The first heart sound (S1) – systolic sound: appears at 0.02 – 0.04s after the QRS complex, lasts 0.12-0.15s, the “lub”, frequency of 30-40Hz, produced, in this order, by: closing of the mitral valve, closing

ADVANCED BIO MEDICAL INSTRUMENTATION

of the tricuspid valve, opening of the pulmonary valve, opening of the aortic valve. Best heard in the mitral and tricuspid auscultatory areas.

The second heart sound (S2) – diastolic sound - appears in the terminal period of the T wave ,lasts 0.08 – 0.12s, the “dub”, frequency of 50-70 Hz, produced, in this order, by: closing of the aortic valve, closing of the pulmonic valve, opening of the tricuspid valve, opening of the mitral valve. Best heard in the 2nd left interspace near the sternal border, Starts after 5 ms after closure of the aortic valves

The third heart sound (S3) - protodiastolic sound ,early diastolic, 100-150 ms after S2 ,lasts 0.02-0.04 s, low frequency, it is normal in children and individuals with a thin thoracic wall,it is produced by the blood flow that hits the ventricular wall during the rapid filling phase

The fourth heart sound (S4) – presystolic sound: appears at 0.04s after the P wave (late diastolic-just before S1) , lasts 0.04-0.10s , low frequency , It is caused by the blood flow that hits the ventricular wall during the atrial systole, causing it to vibrate. It is physiological only in small children

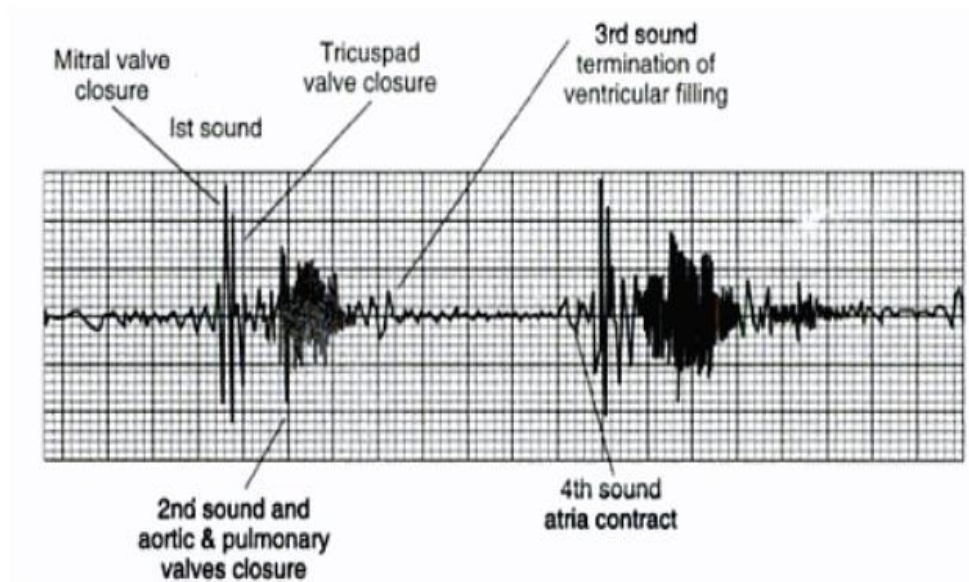

Heart Murmurs

The sources of most murmurs, developed by turbulence in rapidly moving blood, are known. Murmurs are common in children during early systolic phase; they are normally heard in nearly all adults after exercise. Abnormal murmurs may be caused by stenoses and insufficiencies (leaks) at the aortic, pulmonary, and mitral valves. They are detected by noting the time of their occurrence in the cardiac cycle and their location at the time of measurement