

MECHANICAL DESIGN OF MASS TRANSFER COLUMN

Column Construction and Internals

Design and construction features of column internals

Plate construction

Two types of plate constructions are practiced depending on the diameter of the column:

Sectional construction: The trays, downcomer segments and other tray components are usually constructed in sections for column diameter of 1 m and above. The plate sections are designed in such that it can be removed through the column manholes, preferably detachable from both above tray and tray below. The plate sections are installed usually starting from one side on a peripheral supported ring welded to inside shell wall. The support ring is not normally extended into the downcomer area and tray perforations needs to be avoided over the support ring area. Support ring width is usually between 40 to 90 mm. Trays are either clamped or bolted to the support ring.

The support beams prevent tray deflection under load for larger diameter column. One or more major beams are required for large diameter column (usually >3 m). Trays can be supported by support rings and minor beams for small diameter column (usually <3 m) i.e. omitting the major beams. The beams are commonly placed at about 0.6 m apart and should be able to hold on the necessary weight during column operation as well as installation. The maximum plate deflection under the operating conditions should be less than 3 mm for tower diameter more than 2.5 m

The number of plate sections installed under an apron and across accumulator trays is kept as minimum as possible. Clearance should be provided between the bottom of the beams and the tray below for the perpendicular installation of the beams to the liquid flow direction on the tray below (Figure 8.1) i.e. in case of cross flow.

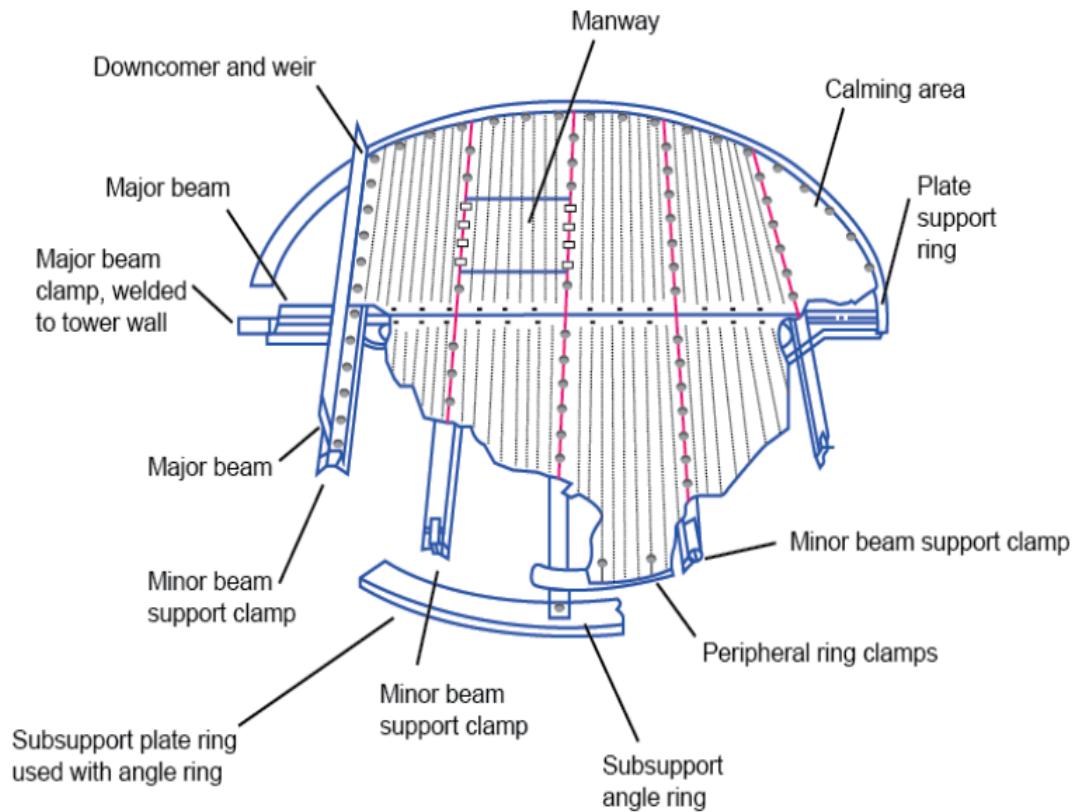

Figure 8.1. Common sectional construction of plate

Cartridge construction

The cartridge or stacked type plate construction is used for column diameter smaller than 1 m as in such small diameter columns man entry to the column for the installation and necessary maintenance work is difficult. Cartridge constructions are employed for sieve, valve and bubble cap trays. The cartridge assemblies of 10 plates or so, are formed with the help of screwed rods and plate spacer bars. The tall column is divided into numbers of flanged sections and the prefabricated cartridge tray assemblies are installed in each flanged sections with suitable downcomer clearance. The plates are not fixed to the shell wall and leakage may occur. A vertical metal seal is frequently used around each tray to decrease leakage around the tray edge (Figure 8.2).

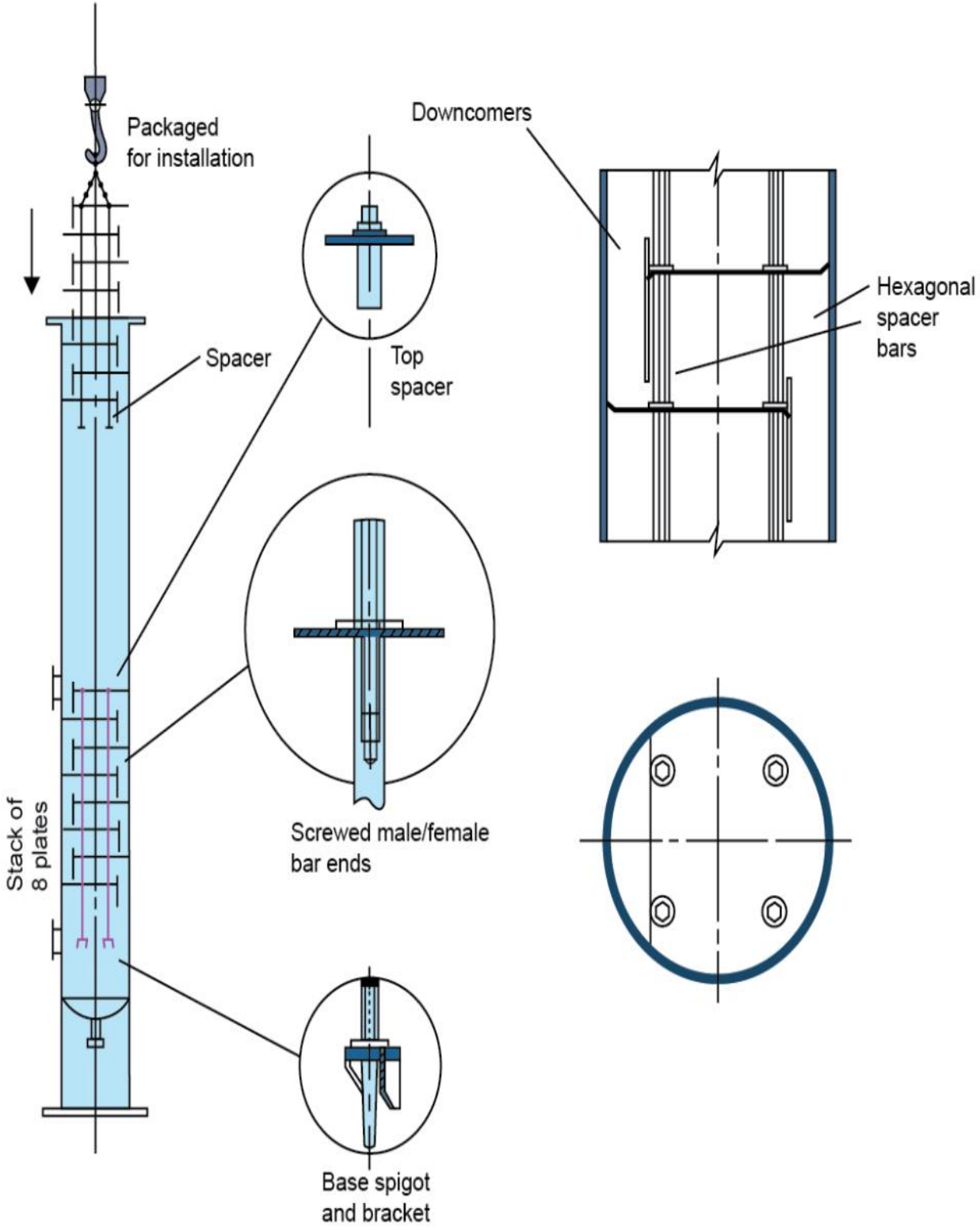

Figure 8.2. Common plate cartridge construction

Downcomer details

The liquid from the top tray is directed to the tray below through a downcomer or downspout. The downcomer liquid flow passage is normally formed by a vertical plate starting from the weir outlet, called an apron. The adequate residence time needs to be ensured in the downcomers for the disengagement of vapor/gas from liquid. The downcomer residence time of more than 3 s is desirable to get only clear liquid on the tray. The different types of segmental downcomers constructions are shown in **Figure 8.3**. The bottom downcomer area is normally more than 50% of the top downcomer area for sloped downcomers.

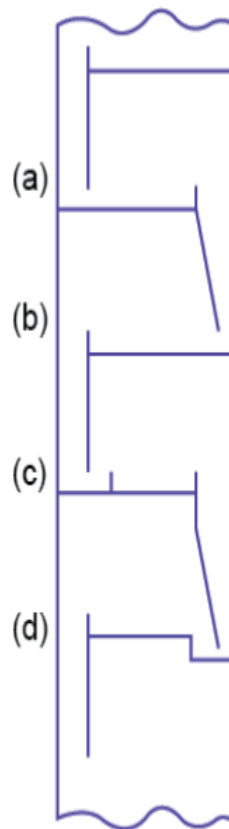

Figure 8.3. Design of segmental downcomers: (a) vertical apron, (b) inclined apron, (c) inlet weir and, (d) recessed well

Feed inlets and side stream draws

The feed liquid is commonly introduced vertically downward into the downcomer of the tray above the feed point through an open pipe. A slotted branch distributor is used for flashing feed (liquid) to avoid early flooding (Figure 8.4). The vapor is generally entered the column tangentially through an open inlet nozzle placed almost at right angles to the liquid flow on the above tray. The clearance between the feed pipe end and feed plate below is normally kept more than 0.4 m when the feed liquid is flashed in active tray area. Wider tray spacing is needed where the feed pipe and the side stream takeoff pipe to provide a liquid seal are installed.

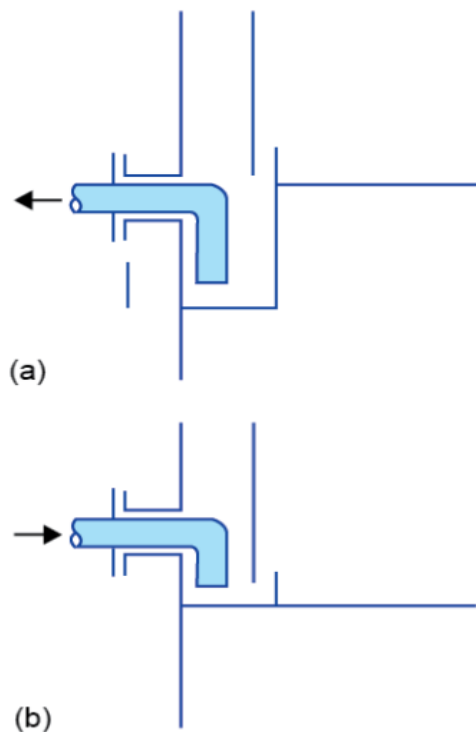

Figure 8.4. (a) Takeoff nozzles (draw off) and, (b) Feed

Tray drainage

Some amount of liquid is usually remains trapped on a bubble cap (positive seal tray) and on certain valve trays when the column is shut down. This liquid is normally drains through weep holes located near the outlet weirs. Weep hole diameter usually ranges from 3 to 15 mm. The recommended weep hole area is 4 inch² per 100ft² of tray area with 50 bubble caps and 4 inch weir to drain in about 8 h

Tray manways

The maintenance workers travel from one tray to another through tray manways (Figure 8.1). The size of the manways should be such that a person can safely travel through a tray manway segment and also it is removable through the column manholes. Manways are usually rectangular and the recommended size is 40 cm×50 cm. Tray manways should be removable from top and as well as from the tray below.

Column design specifications

The column specifications and operating conditions appended below are continued from the process design calculations of sieve plate tower given in module #7.

- Shell ID(D_i):2403mm (D_i is denoted as D_T in module #7)
- Number of trays: 14
- Tray spacing (T_t): 600 mm
- Hole diameter (d_h):12 mm
- Plate thickness (t_t): 12 mm
- Weir height (h_w): 40 mm
- Material for trays, down comers and weirs: Stainless steel SS304L
- Shell material: Stainless steel (SS304L), double welded bolt joints
- Allowable stress for shell material: 108×10^6 Pa (108 MPa)
- Density of shell material (ρ_s) = 7800 kg/m³
- Skirt height: 2 m
- Operating pressure = 118825 Pa (bottom tray pressure)
- Design pressure (p) = 1.1×operating pressure = 130708 Pa
- Operating temperature = 56.3 to 105 °C
- Design temperature = 1.1×maximum operating temperature = 116°C
- Top disengaging space: 600 mm (same as the tray spacing taken)
- Bottom separator space: 1000mm
- Insulation material taken: Asbestos
- Insulation thickness considered: 50 mm
- Density of insulation (ρ_{ins}): 270 kg/m³(asbestos)

Minimum shell thickness (t_s):

$$t_s = \frac{pD_i}{2fj-p} = \frac{130708 \times 2.403}{2 \times (108 \times 10^6) \times 0.8 - 130708}; J = 0.8$$

(8.1)

$$= 1.81 \approx 2 \text{ mm}$$

Use $t_s = 8$ mm thickness including corrosion allowance of 6 mm. This value is in accordance to IS 2844-1964.

Standard ellipsoidal head with $\frac{\text{major axis}}{\text{minor axis}} = 2$:

$$\text{The minimum thickness required, } t_h = \frac{pD_i}{2fj-0.2p} = \frac{130708 \times 2.403}{2 \times (108 \times 10^6) \times 0.8 - 0.2 \times 130708}$$

(8.1)

$$= 1.81 \text{ mm} \approx 2 \text{ mm}$$

The head thickness of 8 mm is selected with corrosion allowance of 6 mm for uniformity.

Column height (H) $\approx T_t + T_t \times 13 + t_t \times 14 + 1000$

$$\approx 600 + 600 \times 13 + 12 \times 14 + 1000 \approx 9.6 \text{ m}$$

[Head height from the cylindrical portion of the column is neglected)

Stresses Developed in Column

Stresses developed in column

Axial and circumferential stresses

The **axial stress (f_{as})** resulting from the internal pressure in a closed cylindrical shell is given by

$$f_{as} = \frac{pD_o}{4jt_s} \quad [\text{Pa}]$$

(8.2)

p = Internal column pressure (usually the design pressure is 5-10% higher than the operating pressure), Pa

D_o = Column outside diameter ($=D_i + 2 \times 8 = 2419 \text{ mm} = 2.419 \text{ m}$), m

t_s = Thickness of the column shell, m

c = Corrosion allowance, m

j = Joint efficiency

$$f_{as} = \frac{130708 \times 2.419}{4 \times 0.8 \times (8 \times 10^{-3})} = 12.4 \times 10^6 \text{ Pa}$$

(8.2)

Circumferential stress (f_{cs}) $= 2 \times f_{as}$

$$(8.3)$$

$$= 24.8 \times 10^6 \text{ Pa}$$

Compressive stresses caused by dead loads

- Stress induced by shell ($f_{\text{dead wt. shell}}$) and insulation ($f_{\text{dead wt. insulation}}$) at any distance, X , from the top of a vessel having a constant shell thickness

$$W_{\text{shell}} = m_{\text{shell}} g = \left[\frac{\pi}{4} (D_o^2 - D_i^2) \rho_s x \right] g$$

(8.4)

Where, W = Weight of shell above point x from column top, kg.m/s²

D_o and D_i = Outside and inside diameter of shell, m

x = Distance measured from the top of the vessel, m

ρ_s = Density of shell material, kg/m³

g = Gravity of the earth, m/s²

m_{shell} = Shell mass, kg

$$m_{\text{shell}} = \left[\frac{\pi}{4} (D_o^2 - D_i^2) \rho_s H \right] \times 1.2$$

(8.5)

$$= \left[\frac{\pi}{4} (2.419^2 - 2.403^2) \times 7800 \times 9.6 \right] \times 1.2$$

≈ 5446 kg including 20% extra weight for head covers, flanges, bolting etc.

Shell weight stress ignoring corrosion allowance:

$$f_{\text{dead wt. shell}} = \frac{m_{\text{shell}} g}{\frac{\pi}{4} (D_o^2 - D_i^2)}$$

(8.6)

$$= \frac{5446 \times 9.81}{\frac{\pi}{4} (2.419^2 - 2.403^2)} \approx 1 \times 10^6 \text{ Pa}$$

$$\text{Weight of insulation, } W_{\text{ins}} = m_{\text{ins}} g = [\pi D_{\text{ins}} \rho_{\text{ins}} x t_{\text{ins}}] g \quad [\text{kg.m/s}^2]$$

(8.7)

Where, D_{ins} = mean insulation diameter, m

t_{ins} = thickness of insulation, m

ρ_{ins} = density of insulation, kg/m^3

Mass of column insulation: $m_{\text{ins}} = \pi D_{\text{ins}} \rho_{\text{ins}} H t_{\text{ins}}$

$$= \pi \times 2.419 \times 270 \times 9.6 \times 0.05 = 985 \quad [\text{kg}]$$

Insulation weight stress:

$$f_{\text{dead wt. insulation}} = \frac{W_{\text{ins}}}{\pi D_m (t_s - c)}$$

(8.8)

$$= \frac{985 \times 9.81}{\pi \times (2.419 + 2 \times 0.05) [(8-6) \times 10^{-3}]} \approx 0.6 \times 10^6 \text{ Pa}$$

D_m = mean shell diameter ($\approx D_{\text{ins}} = D_o + 2 \times$ insulation thickness), m

- Total liquid contents in the column depend on total number of trays, tray liquid holdup, liquid in down comer etc. Stress resulted from liquid retained tower in vessel is given by following equation

$$f_{\text{dead wt. liquid}} = \frac{\sum W_{\text{liquid}}}{\pi D_m (t_s - c)} \quad [\text{Pa}]$$

(8.9)

Mass of liquid in the column:

Liquid depth on trays $\approx 40 + 27.2 \approx 68$ mm [maximum of ($h_w + h_{wc}$) in both sections]

Active area per tray (A_A) = 3.616 m^2 (please refer to **module #7**)

Liquid density = 955 kg/m^3 [maximum liquid density one could get in both sections: **module #7**]

Mass of liquid = $(3.616 \times 14 \times 0.068 \times 955) \times 1.3 \approx 4274 \text{ kg}$

(This includes 30% additional liquid held in downcomers)

$$f_{\text{dead wt. liquid}} = \frac{4274 \times 9.81}{\pi \times (2.419 + 2 \times 0.05) [(8-6) \times 10^{-3}]} \approx 2.6 \times 10^6 \text{ Pa}$$

(8.9)

- Stress induced by column attachments like trays, overhead condenser, instruments, platform, ladders etc

$$f_{\text{dead wt. attachments}} = \frac{\sum W_{\text{attachments}}}{\pi D_m (t_s - c)} \quad [\text{Pa}]$$

(8.10)

Mass of column attachments=5446 kg (Considering 100% of shell mass for column attachments like trays, tray supports, overhead condenser etc.).

$$f_{\text{dead wt. attachments}} = \frac{5446}{\pi \times (2.419 + 2 \times 0.05) [(8-6) \times 10^{-3}]} \approx 3.4 \times 10^6 \text{ Pa}$$

(8.10)

The total dead load stresses, f_{total} acting along the longitudinal axis of the shell:

$$f_{\text{dead, total}} = f_{\text{dead wt. shell}} + f_{\text{dead wt. insulation}} + f_{\text{dead wt. liquid}} + f_{\text{dead wt. attachments}}$$

(8.11)

$$= \underline{\underline{7.6 \times 10^6 \text{ Pa} \ll \text{allowable stress for the shell materials}}}$$

3.3. Axial stresses due to wind loads

The wind loading depends on wind velocity, air density and shape of the column

The maximum anticipated wind pressure of 2500 Pais used in this design. It is considered that fours cables are equally placed for guyed column subtending an angle of 45° with vertical wall. The wind loading acting on a vertical vessel is given by:

$$P_w = \frac{1}{2} C_D \rho_{\text{air}} V_w^2 A$$

(8.12)

Where, C_D = drag coefficient

ρ_{air} = density of air, kg/m³

V_w = wind velocity, m/s

A = projected area of the column normal to the direction of wind, m²

Above the guy ring: The column is designed like an unguyed vessel and the bending moment is given by following equation where $H = x$.

$$M_{w,H} = \frac{1}{2} P_w x^2 D_{\text{eff}}$$

(8.13)

$$= \frac{1}{2} \times 2500 \times 9.6^2 \times (2.419 + 2 \times 0.05) = 290 \text{ kN}$$

D_{eff} = Effective column diameter considering the insulation thickness, m

The bending stress due to wind load:

$$f_{\text{wind},H,\text{above guy}} = \frac{4M_{w,H}}{\pi D_m^2 (t_s - c)} \quad (8.14)$$

$$= \frac{4 \times 290 \times 10^3}{\pi \times 2.419^2 [(8-6) \times 10^{-3}]} = 31.6 \times 10^6 \text{ Pa}$$

Below the guy ring: The maximum bending moment caused by wind load from guyed wire to column located at $\frac{H}{4}$ above the base ($X = \frac{3}{4}H$) is given by

$$M_{w,H,\text{guy (max)}} = \frac{P_w H^2 D_{\text{eff}}}{32} = \frac{M_{w,H}}{16} = 18.12 \text{ kN}$$

(8.15)

Corresponding bending stress:

$$f_{\text{wind},H,\text{below guy}} = \frac{4M_{w,H,\text{g(max)}}}{\pi D_m^2 (t_s - c)} = \frac{f_{\text{wind},H,\text{above guy}}}{16}$$

(8.16)

$$\approx 2 \times 10^6 \text{ Pa}$$

The compressive stress in column induced by guy wire tension, where angle $\theta(45^\circ)$ is making by the guy wires with the vertical wall

$$f_{\text{com},\text{guy}} = \frac{0.04 P_w H D_{\text{eff}}}{\tan \theta (t_s - c) D_o}$$

(8.17)

$$= \frac{0.04 \times 2500 \times 9.6 \times (2.419 + 2 \times 0.05)}{(1) \times [(8-6) \times 10^{-3}] \times 2.419} = 0.5 \times 10^6 \text{ Pa}$$

Analysis of stresses

For upwind side

$$\begin{aligned} \text{Total stress} &= \text{Bending stress } (f_{\text{wind},H,\text{above guy}}) \\ &\quad + \text{Circumferential } (f_{as}) \\ -\text{Radial stress } (f_{\text{dead},\text{total}}) & \qquad \qquad \qquad (8.18) \\ &= 31.6 + 12.4 - 7.6 \approx \mathbf{37 \text{ MPa}} \end{aligned}$$

For downwind side

$$\begin{aligned} \text{Total stress} &= \text{Bending stress } (f_{\text{wind},H,\text{above guy}}) \\ &\quad + \text{Axial stress } (f_{cs}) \\ &\quad + \text{Compressive stress due to guy wires reaction } (f_{\text{com},\text{guy}}) \\ -\text{Radial stress } (f_{\text{dead},\text{total}}) & \qquad \qquad \qquad (8.19) \\ &= 31.6 + 24.8 + 0.25 - 7.6 \approx \mathbf{49 \text{ MPa}} \end{aligned}$$

The maximum stress of 49 MPa is much below the allowable design of stress of 108 MPa and the design is acceptable.

Note: Influence of seismic load is not considered in this lesson. The detailed stress calculations and the underlying theories are discussed in module #6.

Practice problem: Perform the mechanical design of a bubble cap absorption column for the removal of NH_3 from a cracking operation using water as the scrubbing liquid.