

Types of Radiation Interactions

All or Nothing

There is a finite probability per unit length that the radiation is absorbed. If not, there is no interaction

Many Small

The radiation interacts almost continuously giving up a small amount of its energy at each interaction.

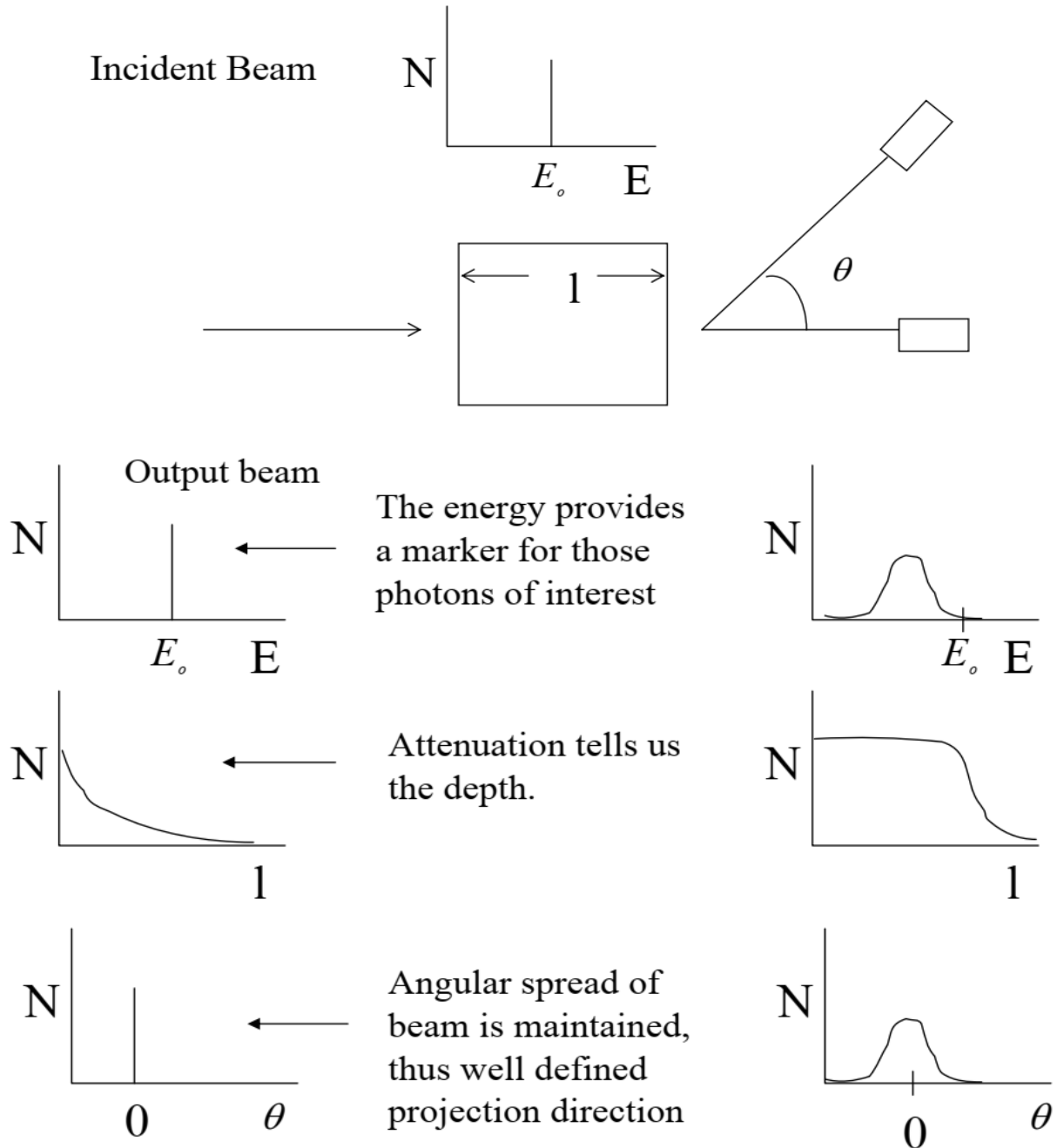

Types of Interactions We Want

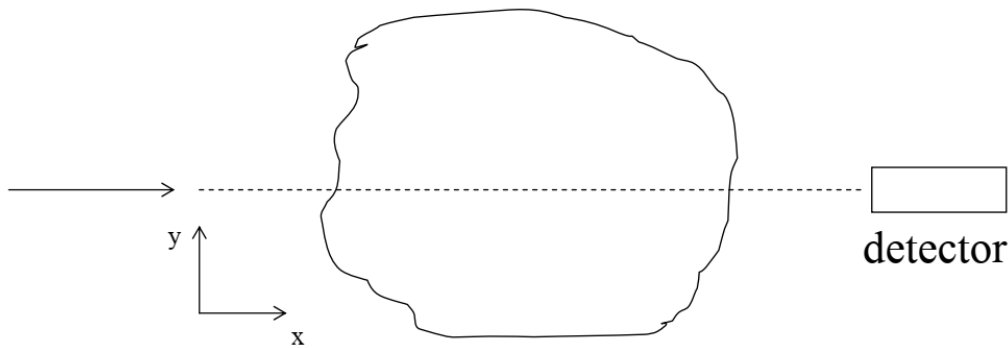

Thus, the reduction in the beam intensity should be a property of the object along the line.

$$\frac{-dI}{I} = \mu dx$$

Where μ is the linear attenuation coefficient and in general is a function of x and y - $\mu(x,y)$

Integrate along the path for a uniform material of length, x .

$$I = I_o e^{-\mu x}$$

In general,

$$I_d(x,y) = I_o e^{-\int \mu(x,y) dx}$$

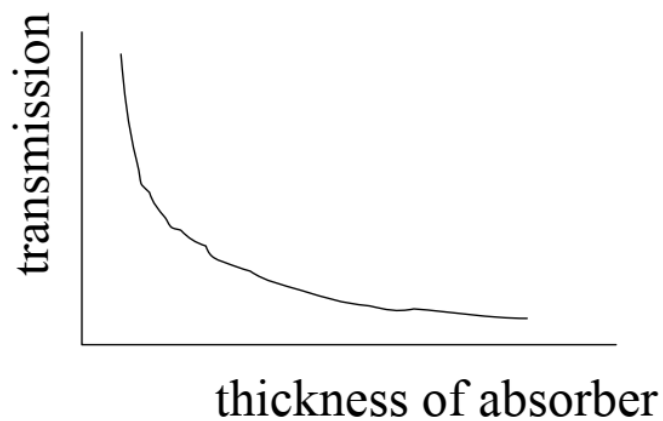

Some details of photon interactions

1. “good” geometry - all photons that interact leave the measurement beam.

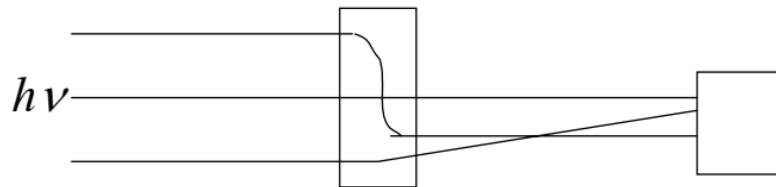

3 approaches

- 1) Restrict geometry to a narrow beam system.
Collimator, place detector at infinity
- 2) Limit interaction to photo-electric (usually safe to assume that characteristic photons do not leave the sample)
- 3) Energy select detected photons

Can define a buildup factor to account for the additional photons at the detector or even in the sample itself.

Consider a sample geometry with only a collimator at the output side

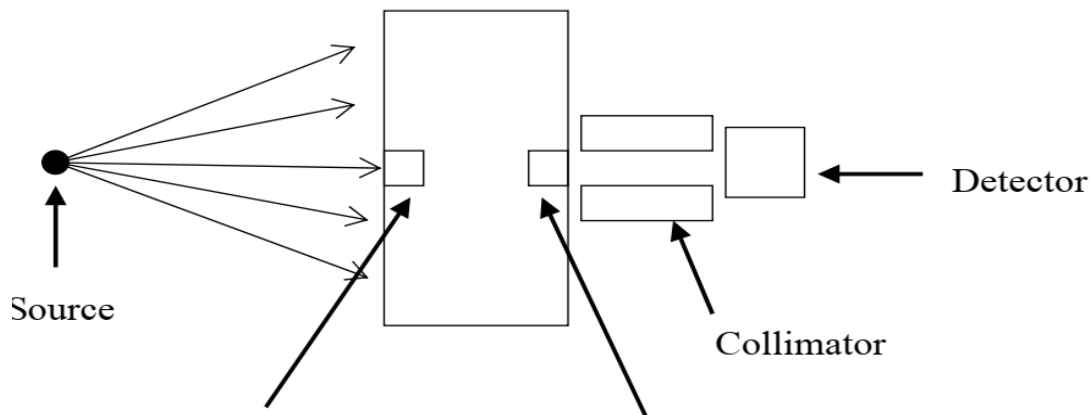

This volume element only sees the normal beam intensity I_0 .

This volume element also sees the excess intensity from the buildup factor.

So the buildup factor can contribute to the signal as well as the noise.

Attenuation Mechanisms (Simple Scatter)

(a) Simple Scatter (Rayleigh Scattering)

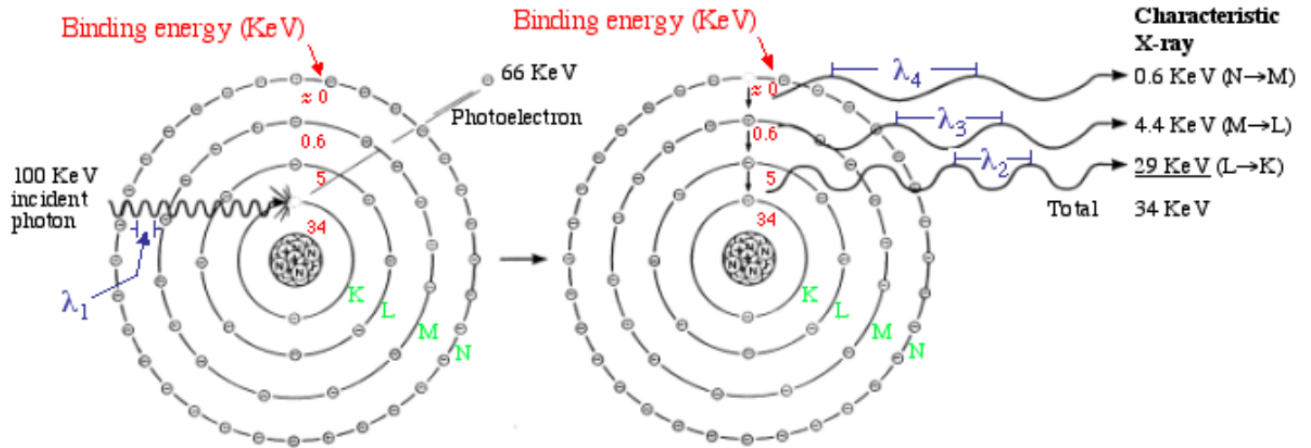

The incident photon energy is much less than the binding energy of the electron in an atom. The photon is scattered without change of energy. Low energy relatively unimportant.

Attenuation Mechanisms (Photoelectric Effect)

(b) Photoelectric effect

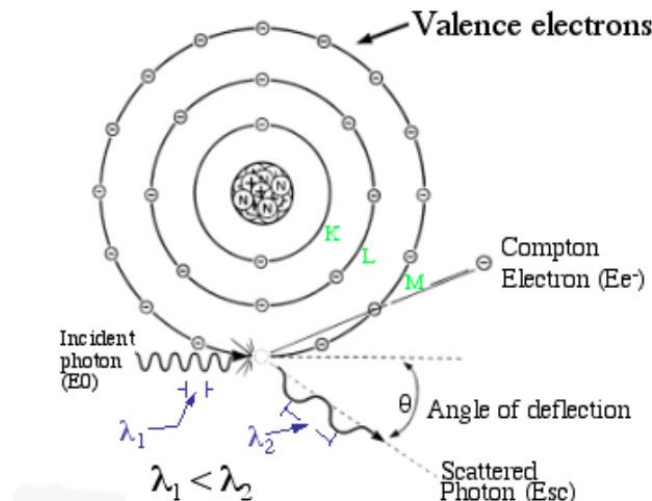

The photon, E slightly greater than E_b gives up all of its energy to an inner shell electron, thereby ejecting it from the atom. The excited atom returns to the ground state with the emission of characteristic photons. Most of these are of relatively low energy and are absorbed by the material.

Attenuation Mechanisms (Compton Scattering)

(c) Compton Scattering

The photon energy is much greater than E_b , and only part of this is given up during the interaction with an outer valence electron (the binding of valence electrons is relatively weak, hence the “free”). The photon is scattered with reduced energy and the energy of the electron is dissipated through ionizations.

Attenuation Mechanisms (Pair Production)

(d) Pair Production

A very high energy photon interacts with a nucleus to create an electron/positron pair. The mass of each particle is 9.11×10^{-31} kg. So the minimum photon energy is:

$$\begin{aligned} E_{\min} &= 2 \times 9.11 \times 10^{-31} \text{ kg} \times \left(3 \times 10^8 \text{ m/sec} \right)^2 \\ &= 1.64 \times 10^{-13} \text{ J} \\ &= 1.02 \text{ MeV} \end{aligned}$$

Both the electron and the positron lose energy via ionization until an annihilation event takes place yielding two photons of 0.51 MeV moving in opposite directions.

Tissue Transparency

Ultrasound

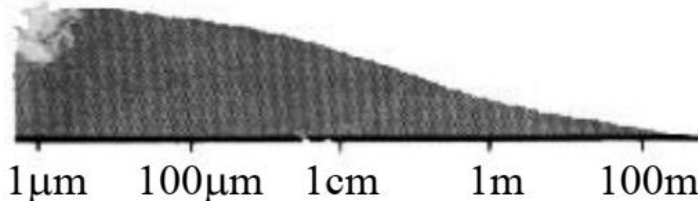

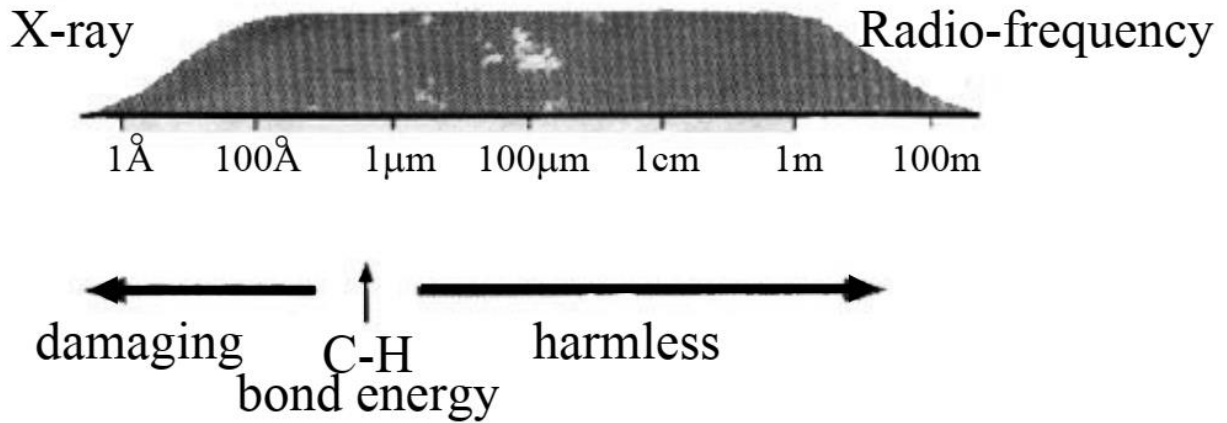

Windows of transparency in imaging via sound and electromagnetic radiation. The vertical scale measures absorption in tissue.

Attenuation Mechanisms

<u>Mechanism</u>	μ dependence		<u>Energy Range in Soft Tissue</u>
	<u>E</u>	<u>Z</u>	
simple scatter	$1/E$	Z^2	1-20 keV
photoelectric	$1/E^3$	Z^3	1-30 keV
Compton	falls slowly with E	independent	30 keV-20 MeV
pair production	rises slowly with E	Z^2	above 20 MeV

Attenuation Mechanisms 2

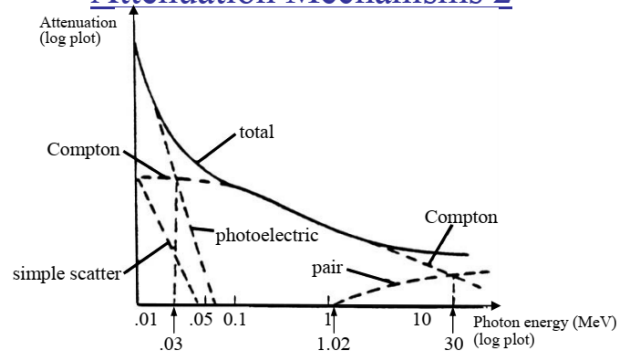

Attenuation mechanisms in water

The optimum photon energy is about 30 keV (tube voltage 80-100 kV) where the photoelectric effect dominates. The Z^3 dependence leads to good contrast:

Z_{fat}	5.9
Z_{muscles}	7.4
Z_{bone}	13.9

⇒ Photoelectric attenuation from bone is about 11x that due to soft tissue, which is dominated by Compton scattering.

Beam Energy

So, beam energy is important

$$I_d(x,y) = \int I_o(\epsilon) e^{-\int \mu(x,y,\epsilon) dx} d\epsilon$$

This does not include buildup factor or scattering but does include beam hardening

Also need to consider beam energy even if only photoelectric effect, since absorption rate depends on the energy. Thus, low energy photons deliver no useful information.



Consider contrast agents, add a material to enhance contrast (more attenuation)

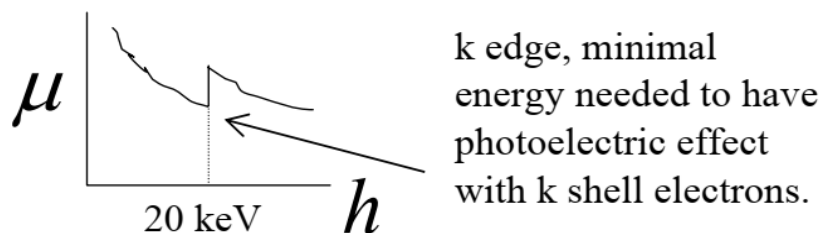

Increase the contrast, decrease the signal, increase the dose

Heterogeneous Case

Interested in the heterogeneous case

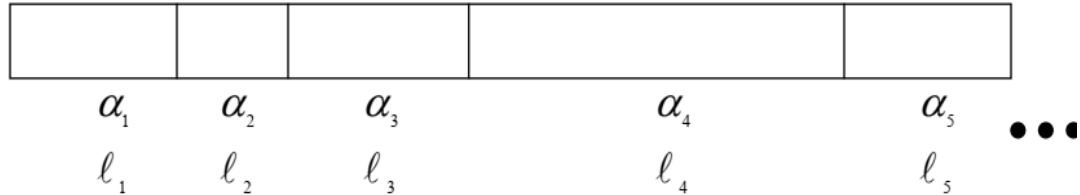

then

$$I = I_o e^{-(\alpha_1 \ell_1 + \alpha_2 \ell_2 + \dots + \alpha_N \ell_N)}$$

$$\text{where } \sum_{N_i=1}^N \ell_i = L$$

Thus, in a continuously varying medium

$$I = I_o e^{-\int_0^L \alpha dl}$$

a line integral over the sample and defined by the ray of interaction

$$-\ln \frac{I}{I_o} = \underbrace{\int_0^L \alpha dl}_{\text{this is the projection}}$$

$$P(\theta, z) = -\ln \frac{I(\theta, z)}{I_o(\theta, z)} = \int_0^L \alpha(l) dl$$

We wish to reconstruct the linear attenuation coefficient $\alpha(l)$

In 2D,

$$P(\theta, z) = \int_L \alpha(x, y) dl$$

X-ray Attenuation Coefficients

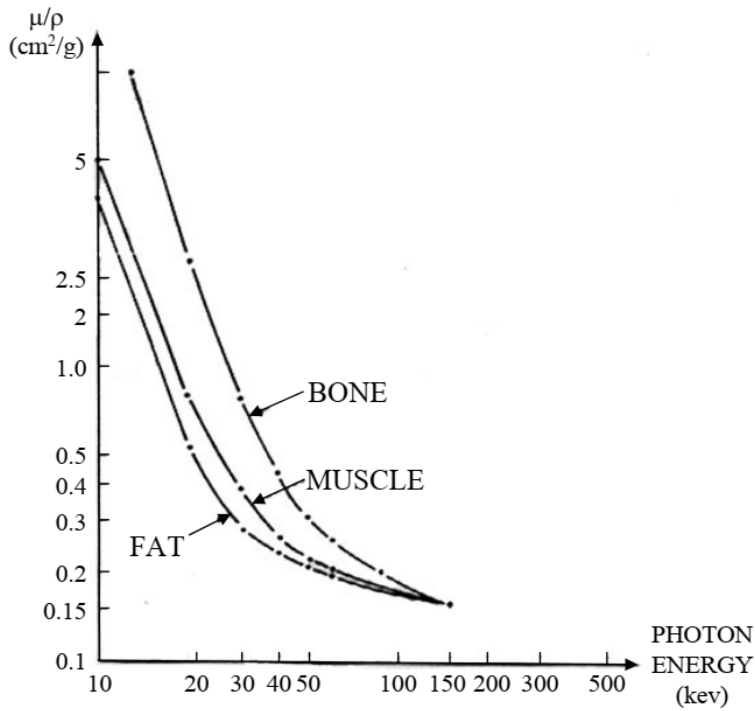

X-ray attenuation coefficients for muscle, fat, and bone, as a function of photon energy.

Photoelectric Effects Predominates

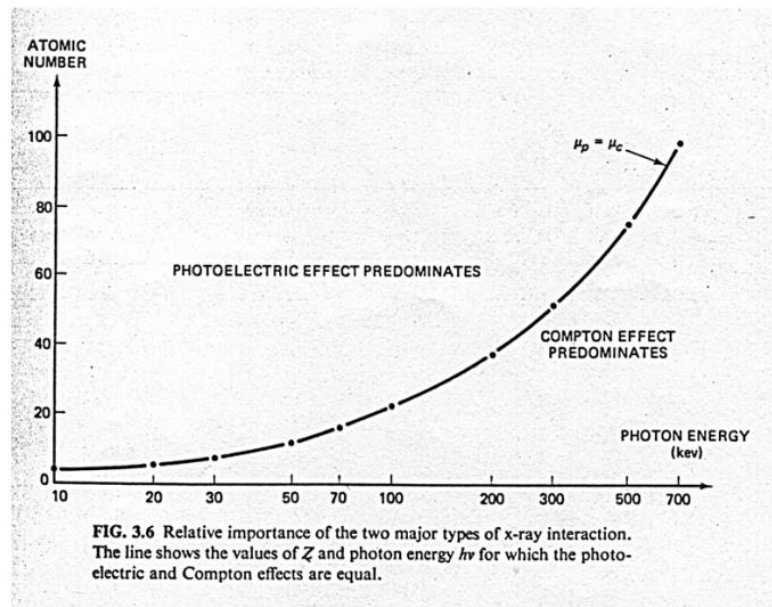
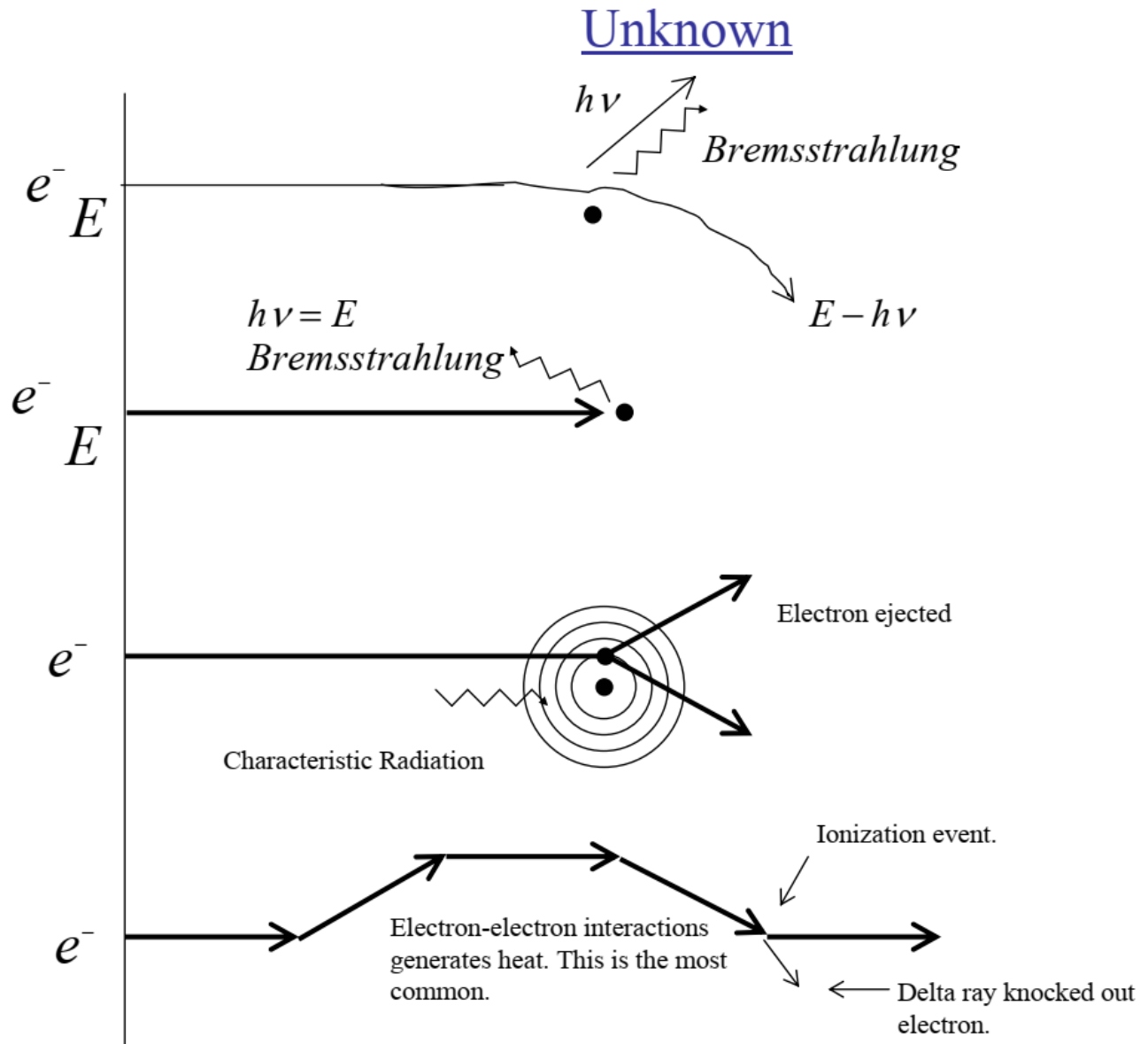
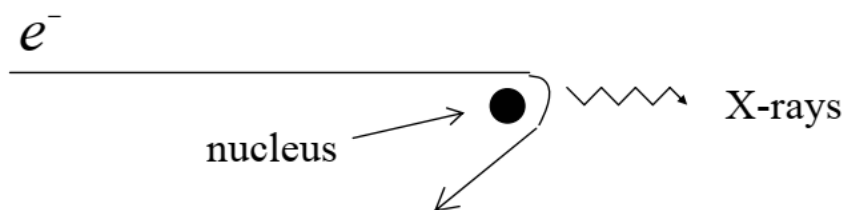

FIG. 3.6 Relative importance of the two major types of x-ray interaction. The line shows the values of Z and photon energy $h\nu$ for which the photoelectric and Compton effects are equal.



Bremsstrahlung - Breaking Radiation



Coulombic interaction between electron and a nuclear charge

For each interaction, the X-ray spectrum is white and the electron loses some energy.

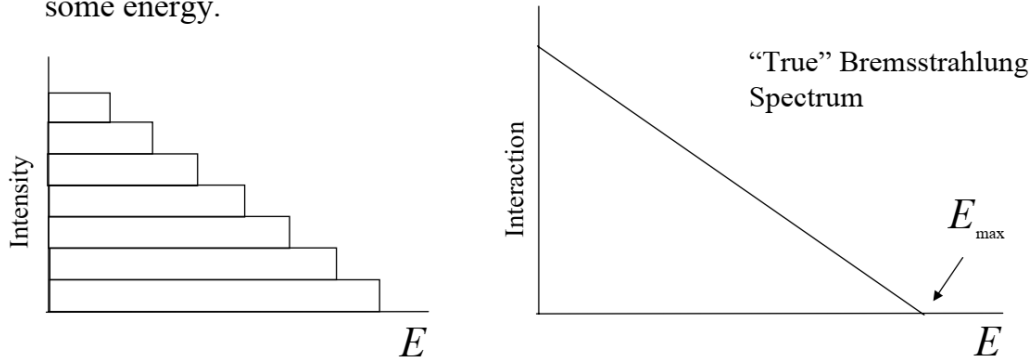

More Details On X-ray Tubes

- electrons are boiled off filament
- accelerated through a high vacuum from the cathode to the anode
- electrons strike the anode, a tungsten target, and create X-rays
- X-rays are emitted in all directions though only a cone is used
- 99% of the electric energy is dissipated a heat into the anode. Typically less than 1% of the energy is converted into useful X-rays.
- X-rays that are diverted into the target are absorbed and contribute to the production of heat.

The Origins of X-Rays

X-rays are high energy (> 1keV) electromagnetic radiation. They are often produced by bombarding a metal target with high-speed electrons.

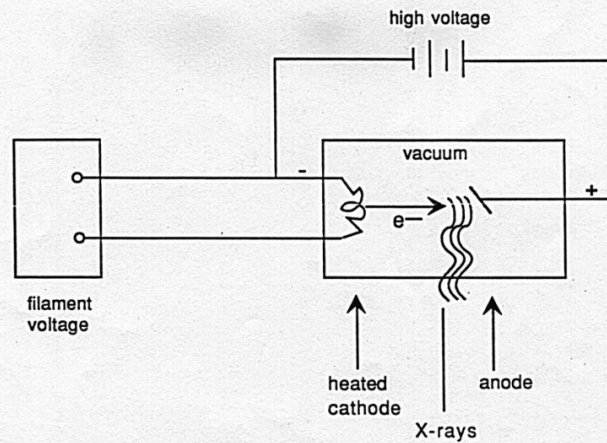

A heated cathode emits electrons by thermionic emission. These are accelerated to the anode and the target. The electrons lose about 99 percent of their energy in lowenergy collisions (producing mostly heat), and about one percent reappears as X-rays.

The X-Ray Spectrum

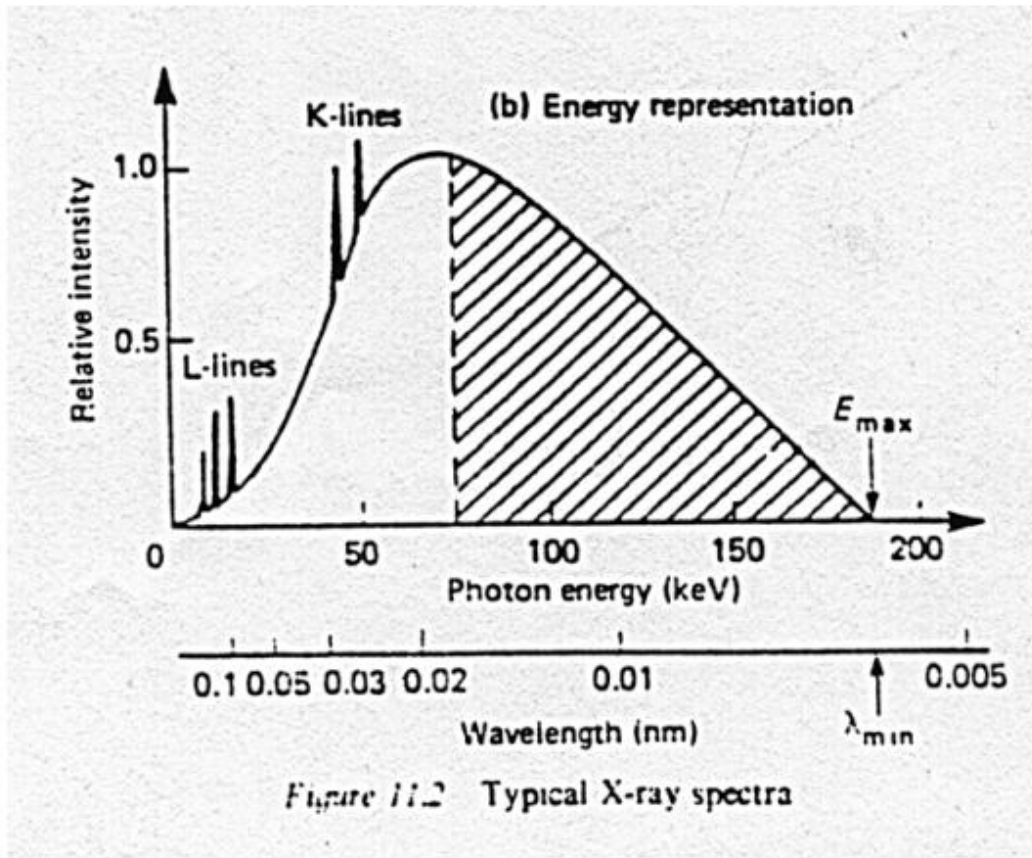

Unknown

But interactions filter out low energy

Usually place some material between tube and object to further reduce low X-rays

Need to take care in designing a filter so as not to create low energy characteristic lines.

Bremsstrahlung

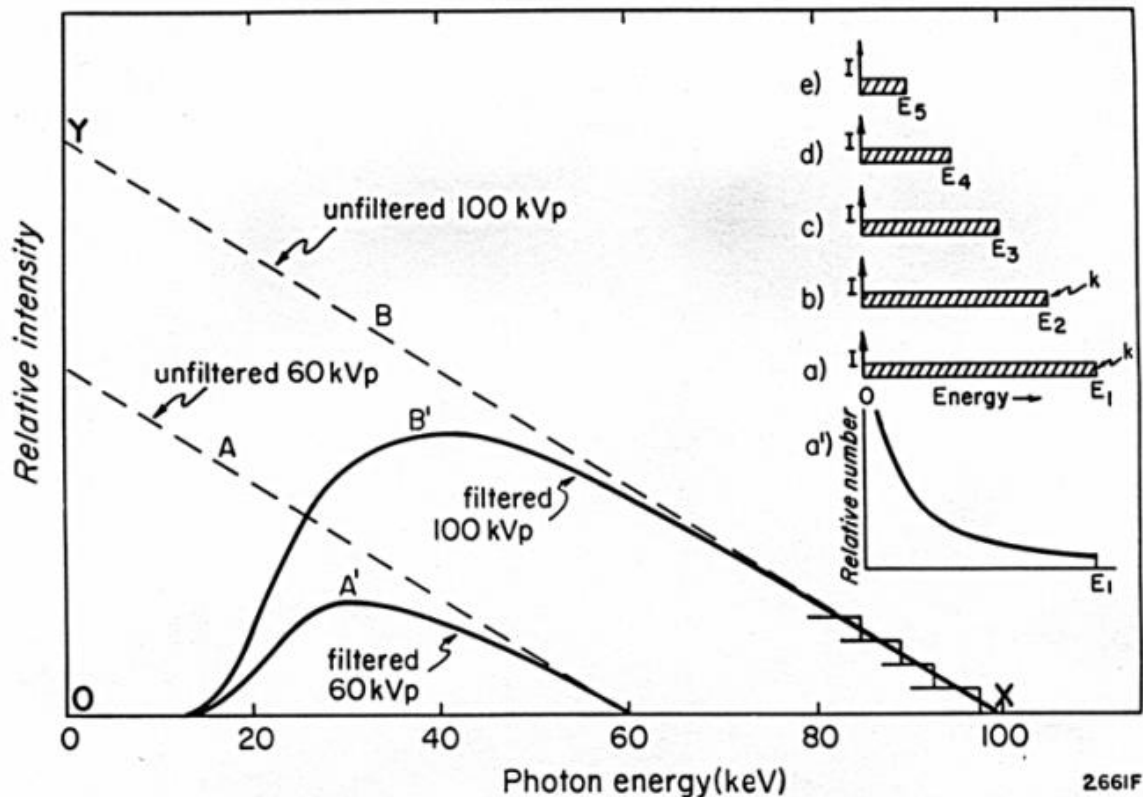

Figure 2-15. Relative energy or intensity I , in each photon energy interval produced when a beam of monoenergetic electrons of energy E_1 bombard a thin target. The distribution a' is the data of a converted to a number distribution. Curves $b, c, d,$ and e are thin target intensity spectra similar to a but for electron energies of $E_2, E_3, E_4,$ and E_5 . The main diagram shows *thick target* spectra (dotted lines A and B) produced by the superposition of many thin target spectra when the target is bombarded with 60 and 100 keV electrons. The solid curves A' and B' were obtained from A and B by taking into account the attenuation of 2 mm Al.

The X-Ray Spectrum (Changes in Voltage)

The continuous spectrum is from electrons decelerating rapidly in the target and transferring their energy to single photons, Bremsstrahlung.

$$E_{\max} = eV_p$$

$V_p \equiv$ peak voltage across the X-ray tube

The characteristic lines are a result of electrons ejecting orbital electrons from the innermost shells. When electrons from outer shells fall down to the level of the inner ejected electron, they emit a photon with an energy that is characteristic to the atomic transition.

Changes in the voltage:

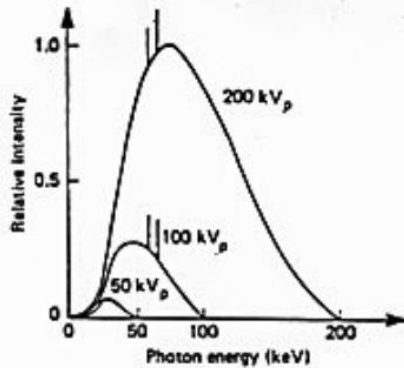

When the voltage is increased:

- 1) $E_{\max} \propto V_p$
- 2) peak of continuous spectrum moves to higher energy
- 3) total output intensity $\propto V_p^2$
- 4) more characteristic lines may appear

The X-Ray Spectrum (Changes in tube)

Changes in tube current:

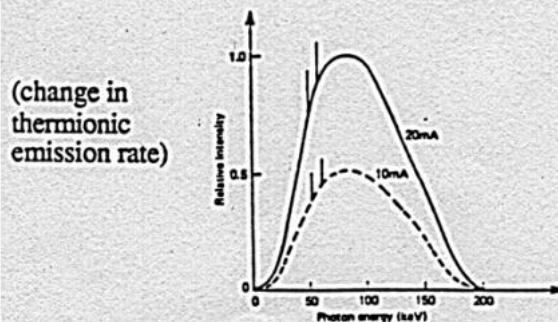

(change in thermionic emission rate)

- 1) shape remains the same
- 2) E_{\max} remains unchanged
- 3) total output intensity $\propto I$

Figure 11.4 Effect of tube current on spectrum

The X-Ray Spectrum (Changes in Target Material)

Increase in Z :

1. Increase in X-ray intensity since greater mass and positive charge of the target nuclei increase the probability of X-ray emission total output intensity of Z
2. Characteristic lines shift to higher energy, K and L electrons are more strongly held
3. No change in E_{\max}