

1. (4 pts) Rank the following carbocations in order of stability (1 = most stable).

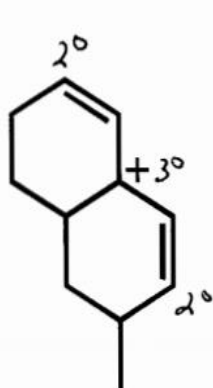

2

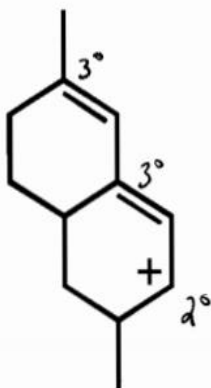

1

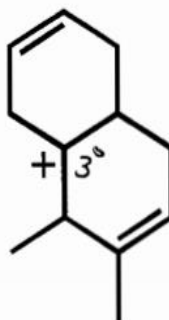

3

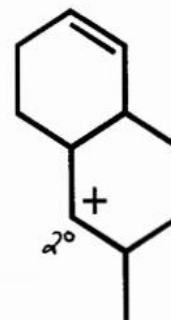

4

2. (4 pts) Rank the following alkenes according to energy (1 = lowest energy).

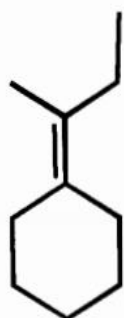

1



4

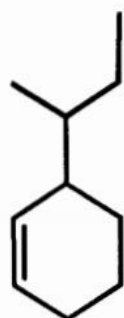

3

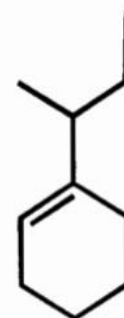

2

3. (8 pts) For each of the following reactions:

- label the nucleophile as lone pair (n), pi bond ( $\pi$ ), or sigma bond ( $\sigma$ )
- label the electrophile as empty orbital (a), pi bond ( $\pi^*$ ), or sigma bond ( $\sigma^*$ )
- use curved arrows to show attack of the nucleophile on the electrophile
- show the product of each reaction

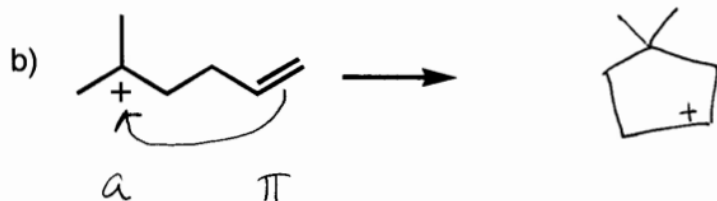
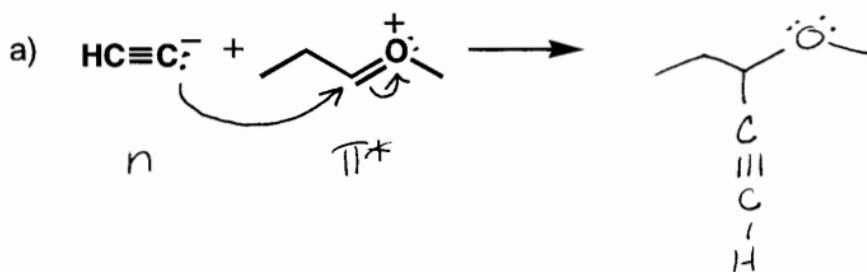

4. (8 pts) Draw a reaction coordinate diagram for a reaction with the following criteria:

- a) exergonic, 3-step reaction
- b) the first-step is the rate-determining step
- c) the second intermediate is more stable than the first intermediate
- d) the third step of the reaction is faster than the reverse of the second step

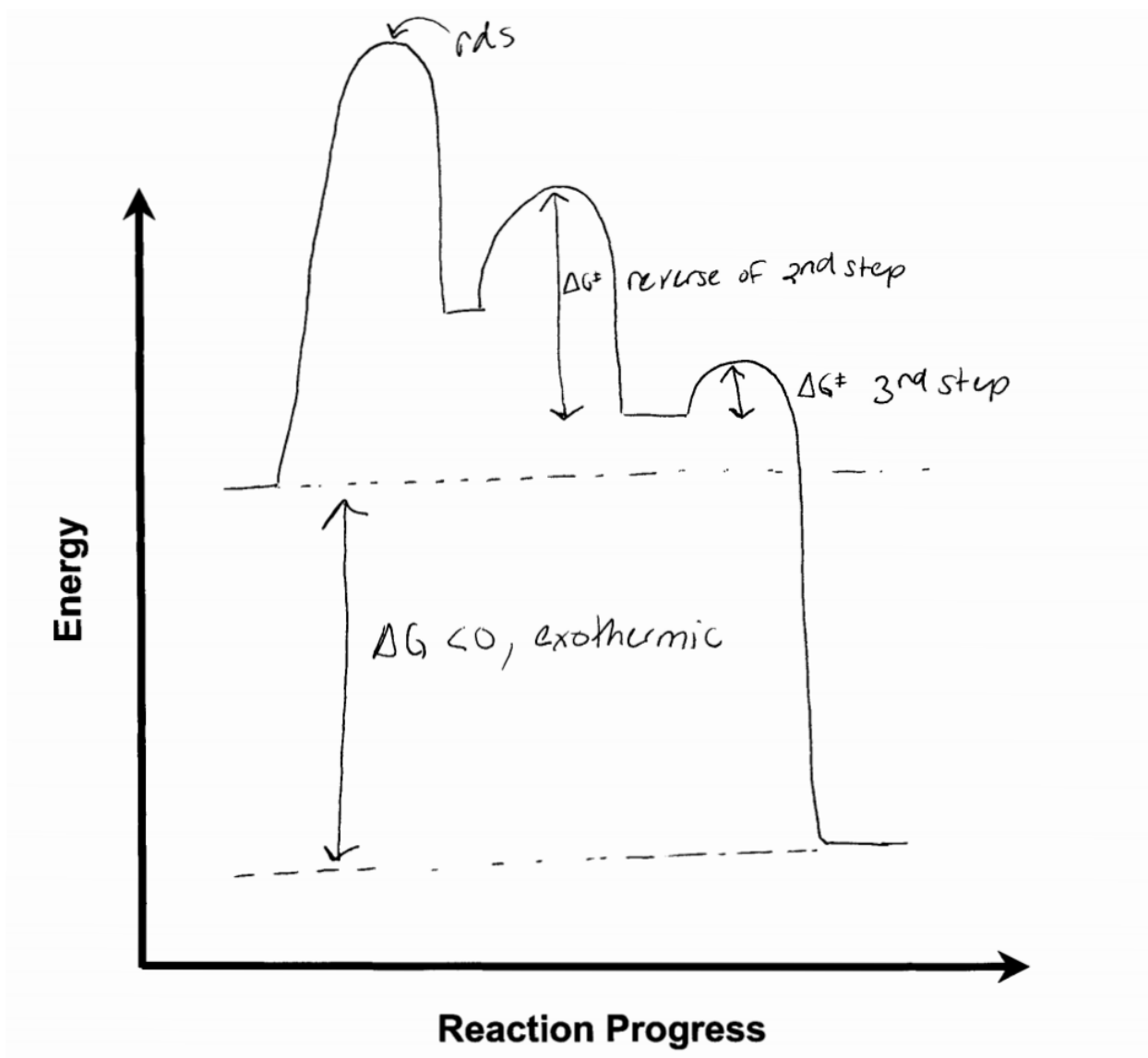

5. (8 pts) Show the product(s) of each reaction. Ignore stereochemistry.

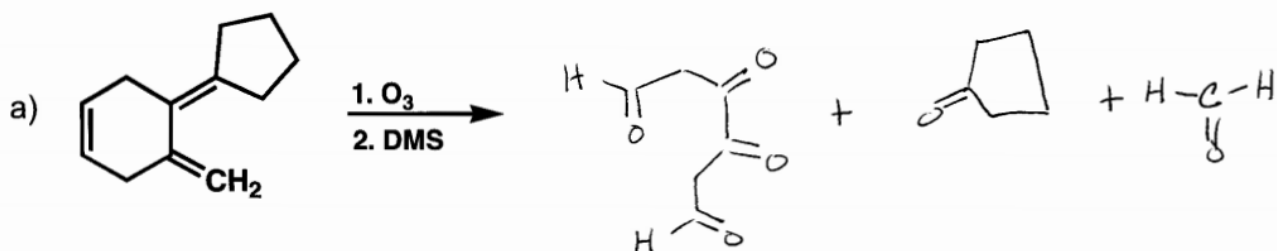

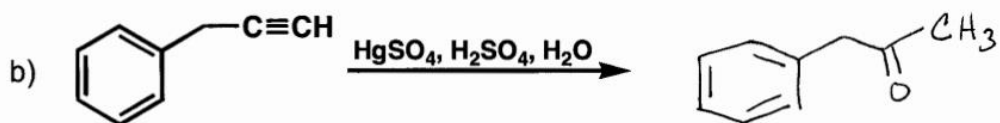

6. (8 pts) Provide products for the following reactions (include all stereoisomers). Indicate if the products are achiral/optically inactive (A) racemic/optically inactive (R), meso/optically inactive (M) or chiral/optically active (C).

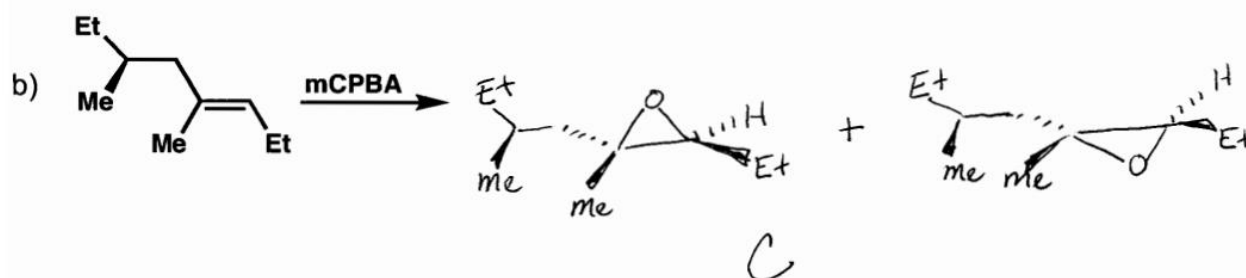
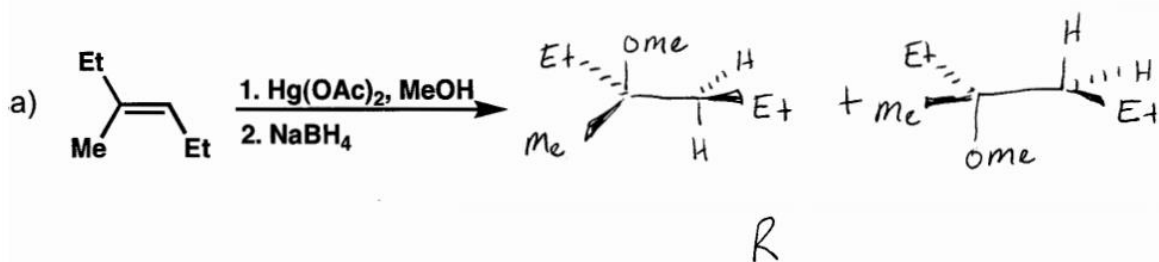

7. (12 pts) Provide the major product of each reaction. Include stereochemistry.

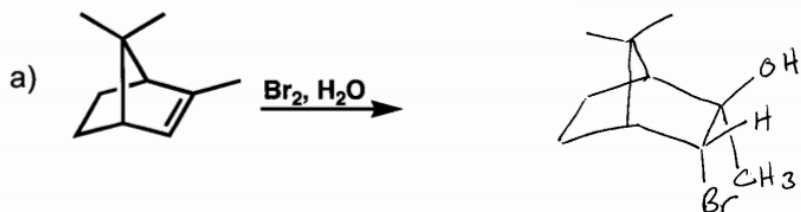

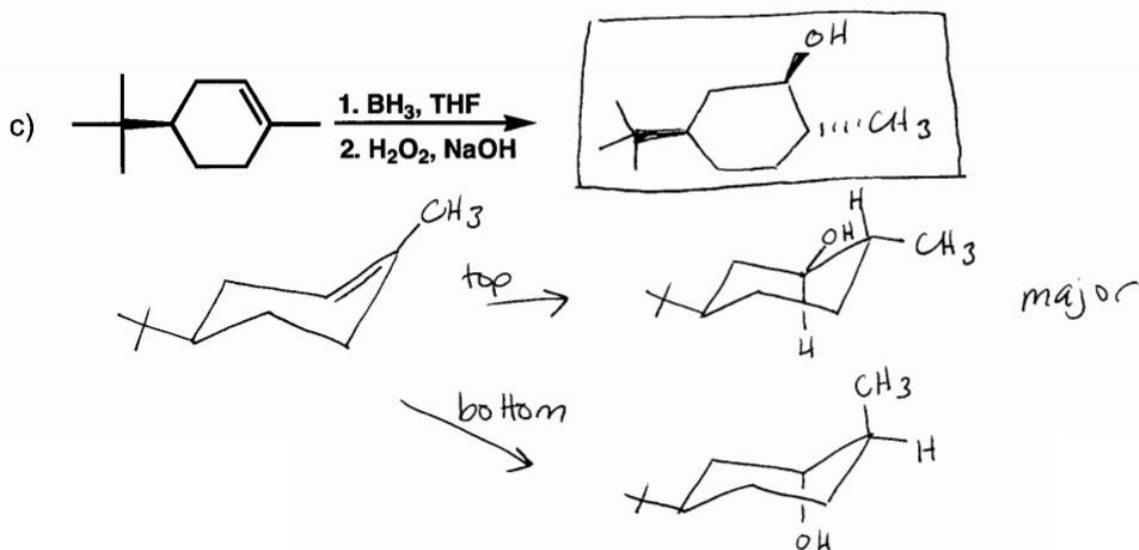
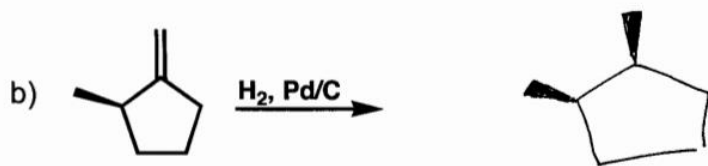

8. (6 pts) Provide an appropriate alkyne starting material, reagents and initial product for the reaction in the boxes provided. The number of carbon atoms in the starting material should equal the number of carbon atoms in the final product.

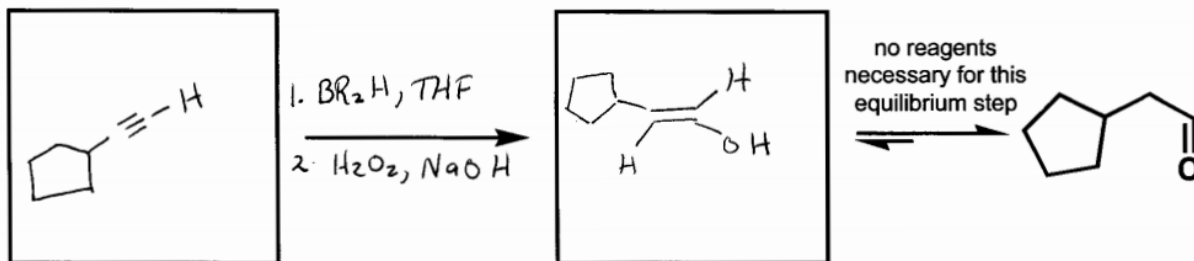

9. (6pts) Provide the missing reagents above each reaction arrow and the final product in the box.

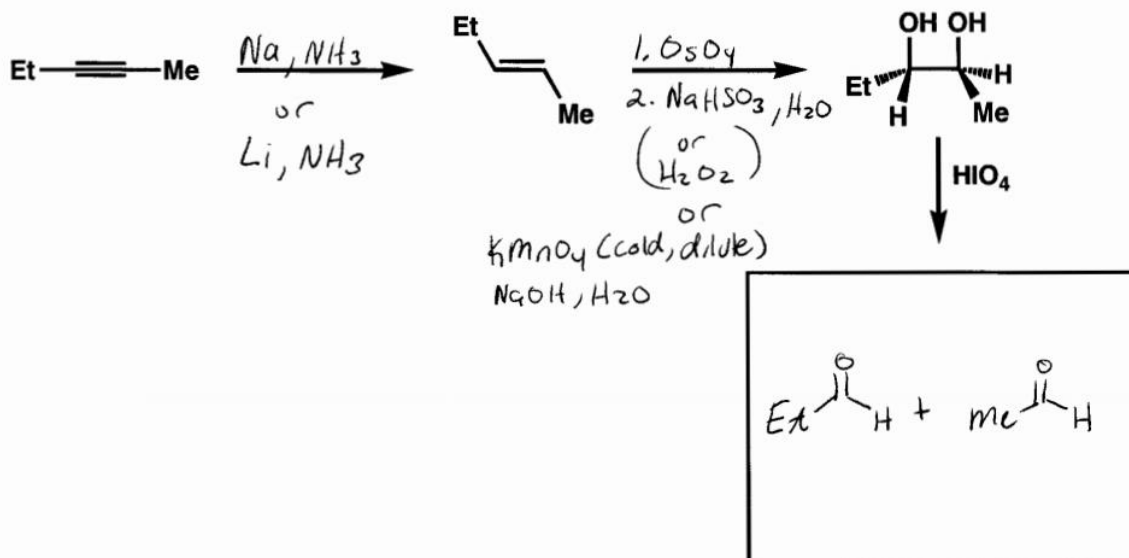

10. (8 pts) Provide an alkyne starting material and all necessary reagents to complete the following 2-step reaction.

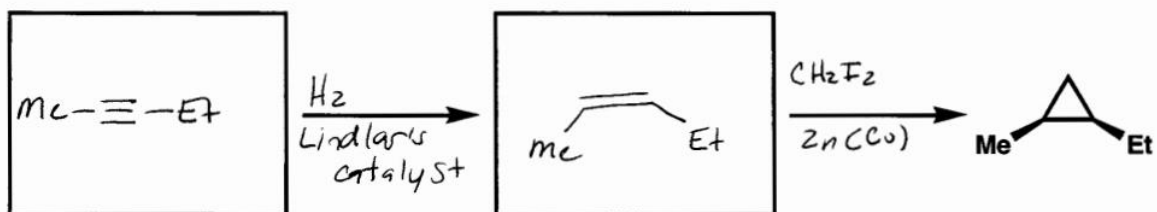

11. (18 pts) Provide the mechanism and **major** product for each of the following reactions. Ignore stereochemistry.

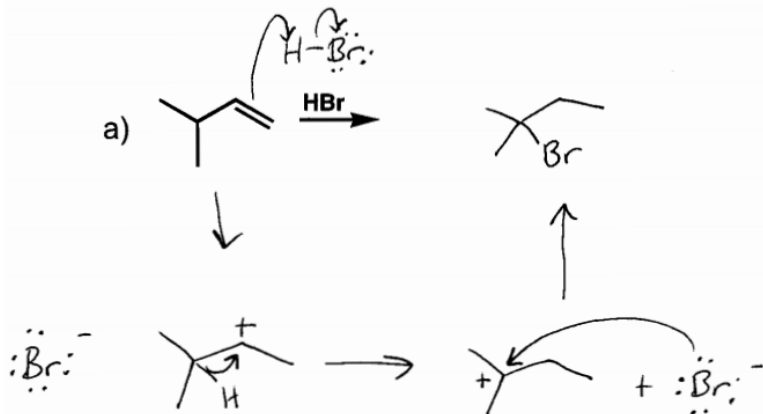

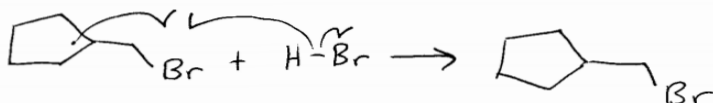
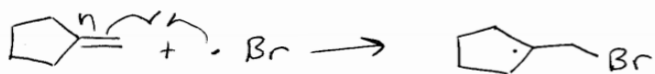
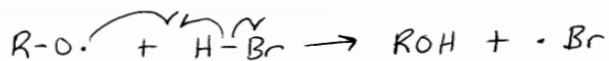
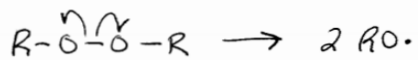
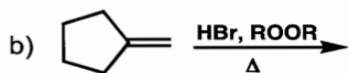

12. (10 pts) Propose a mechanism for the following reaction. Ignore stereochemistry.

